

This copy is a reprint which includes current pages from Changes 1 and 2.

DEPARTMENT OF THE ARMY TECHNICAL MANUAL

---

TECHNICAL MANUAL

OPERATOR AND ORGANIZATIONAL

MAINTENANCE MANUAL

TRUCK, LIFT, FORK, GASOLINE

ENGINE DRIVE, SOLID RUBBER

TIRES, 127 INCH LIFT, 2000

POUND CAPACITY

(ARMY MODEL MHE-229)

(CLARK EQUIPMENT CO. MODEL 2329397)

NSN 3930-00-315-9699

---

HEADQUARTERS, DEPARTMENT OF THE ARMY

APRIL 1975

## WARNING

### DANGEROUS GASES

When servicing battery, do not smoke or use flame in the vicinity. Batteries generate hydrogen, a highly explosive gas.

Do not fill fuel tank while engine is running. Provide metallic contact between the fuel container and fuel tank to prevent a static spark from igniting fuel. Wipe or flush any spillage.

Make sure fire extinguisher (Class B) is on the truck.

Use caution when approaching doorways, aisles, intersections or other workers.

Avoid sudden starting and stopping. Reduce speed on turns.

Know the rated capacity of the truck and do not overload it.

Do not operate vehicle for prolonged periods in an unventilated area. All gasoline engines produce poisonous carbon monoxide gas which is extremely toxic if allowed to accumulate in a closed area.

Immediately remove from service any vehicle evidencing a defect or malfunction which might prove hazardous to operating personnel, or cause further damage to equipment. Such defects must be corrected immediately, regardless of scheduled maintenance actions.

Do not remove the radiator cap from an overheated radiator; stop engine and allow radiator to cool before removing cap to avoid injury by scalding.

Make sure forks are lowered to the ground and hand brake is engaged firmly.

If the truck is parked on an incline, set brakes and block at least two wheels in the event of hand brake failure.

Immediately remove from service any vehicle showing a defect or malfunction which might prove hazardous to operating personnel or cause further damage to equipment.

Do not remove radiator cap from an overheated radiator. Stop engine and allow radiator to cool before removing cap to avoid injury by scalding.

If vehicle is parked on an incline, set brakes and block at least 2 wheels as a precaution against hand brake failure.

Dry cleaning solvent, P-D-680, used to clean parts is potentially dangerous to personnel and property. Avoid repeated and prolonged skin contact. Do not use near open flame or excessive heat. Flash point of solvent is 100 degrees F. (38 ° C.)-138 ° F. (60 ° C.).

CHANGE  
NO. 2

HEADQUARTERS  
DEPARTMENT OF THE ARMY  
WASHINGTON, D.C., 22 October 1984

**OPERATOR AND ORGANIZATIONAL MAINTENANCE MANUAL**

**TRUCK, LIFT, FORK, GASOLINE ENGINE DRIVEN,**

**SOLID RUBBER TIRES, 127 INCH LIFT,**

**2000 POUND CAPACITY**

**(ARMY MODEL MHE-229)**

**(CLARK EQUIPMENT CO. MODEL 2329397)**

**NSN 3930-00-315-9699**

TM 10-3930-632-12, 10 April 1975, is changed as follows:

1. Remove old pages and insert new pages as indicated below.
2. New or changed material is indicated by a vertical bar in the margin of the page.
3. Added or revised illustrations are indicated by a vertical bar adjacent to the illustration identification number.

*Remove Pages*

i through iv  
4-23 and 4-24  
4-59 and 4-60  
4-61 and 4-62  
4-67 and 4-68  
4-69 and 4-70  
4-75 and 4-76  
A-1  
B-1 through B-5  
C-1  
Index I-1 through Index 1-5

*Insert Pages*

i through iv  
4-23 and 4-24  
4-59 and 4-60  
4-61/(4-62 blank)  
4-67/(4-68 blank)  
4-70/(4-69 blank)  
4-76/(4-75 blank)  
A-1/(A-2 blank)  
B-1 through B-9/(B-10 blank)  
C-1/(C-2 blank)  
Index I-1 through Index I-5/(I-6 blank)

4. File this change sheet in front of the publication for reference purposes.

By Order of the Secretary of the Army:

JOHN A. WICKHAM, JR.  
*General, United States Army*  
*Chief of Staff*

Official:

ROBERT M. JOYCE  
*Major General, United States Army*  
*The Adjutant General*

Distribution:

To be distributed in accordance with DA Form 12-25A, Operator; Organizational Maintenance requirements for Warehouse Equipment.

CHANGE

No. 1

HEADQUARTERS  
DEPARTMENT OF THE ARMY  
WASHINGTON, D.C., 24 May 1982

**OPERATOR AND ORGANIZATIONAL MAINTENANCE MANUAL**

**TRUCK, LIFT, FORK, GASOLINE ENGINE DRIVE,**

**SOLID RUBBER TIRES, 127 INCH LIFT,**

**2000 POUND CAPACITY**

**(ARMY MODEL MHE-229)**

**(CLARK EQUIPMENT CO. MODEL 2329397)**

**NSN 3930-00-315-9699**

TM 10-3930-632-12, 10 April 1975, is changed as follows:

1. Remove old pages and insert new pages as indicated below. New or changed material is indicated by a vertical bar in the margin of the page. Added or revised illustrations are indicated by a vertical bar adjacent to the illustration identification number. When an entire section or paragraph is added or revised, a vertical bar is placed adjacent to the title only.

*Remove Pages*

*Insert Pages*

|                       |                       |
|-----------------------|-----------------------|
| 1-1 through 1-4 ..... | 1-1 through 1-4       |
| 3-1 and 3-2 .....     | 3-1 and 3-2           |
| None.....             | 3-2.1 and 3-2.2       |
| 4-1 through 4-6 ..... | 4-1 through 4-6       |
| None.....             | 4-6.1 and 4-6.2       |
| 4-9 and 4-10 .....    | 4-9 and 4-10          |
| None.....             | 4-10.1 (4-10.2 blank) |
| 4-29 and 4-30 .....   | 4-29 and 4-30         |
| 4-73 and 4-74 .....   | 4-73 and 4-74         |

2. File this change sheet in front of the publications for reference purposes.

By Order of the Secretary of the Army:

Official:

ROBERT M. JOYCE  
*Brigadier General United States Army*  
*The Adjutant General*

E. C. MEYER  
*General, United States Army*  
*Chief of Staff*

Distribution:

To be distributed in accordance with DA Form 12-25A, Operator Maintenance requirements for Warehouse Equipment.

TECHNICAL MANUAL  
No. TM 10-3930-632-12

HEADQUARTERS  
DEPARTMENT OF THE ARMY  
WASHINGTON, D.C., 10 April 1975

**OPERATOR AND ORGANIZATIONAL MAINTENANCE MANUAL**

**TRUCK, LIFT, FORK, GASOLINE ENGINE DRIVEN,**

**SOLID RUBBER TIRES, 127 INCH LIFT,**

**2000 POUND CAPACITY**

**(ARMY MODEL MHE-229)**

**(CLARK EQUIPMENT CO. MODEL 2329397)**

**NSN 3930-00-315-9699**

|          |        |  |      |      |
|----------|--------|--|------|------|
| CHAPTER  | 1.     | INTRODUCTION   |      |      |
| Section  | I.     | General.....   | 1-1  | 1-1  |
| Section  | II.    | Description and Data.....  | 1-7  | 1-1  |
| CHAPTER  | 2.     | OPERATING INSTRUCTIONS   |      |      |
| Section  | I.     | Opting Procedures .....  | 2-1  | 2-1  |
|          | II.    | Operation under Unusual Conditions.....                                  | 2-8  | 2-4  |
| CHAPTER  | 3.     | OPERATOR/CREW MAINTENANCE INSTRUCTIONS                                   |      |      |
| Section  | I.     | Lubrication Instructions .....   | 3-1  | 3-1  |
|          | II.    | Preventive Maintenance Checks and Services.....                          | 3-3  | 3-1  |
|          | III.   | Troubleshooting .....  | 3-5  | 3-3  |
| CHAPTER  | 4.     | ORGANIZATIONAL MAINTENANCE INSTRUCTIONS                                  |      |      |
| Section  | I.     | Service Upon Receipt of Materiel.....                                    | 4-1  | 4-1  |
|          | II.    | Movement to a New Worksite .....   | 4-2  | 4-1  |
|          | III.   | Repair Parts, Special Tools and Equipment .....                          | 4-4  | 4-1  |
|          | IV.    | Lubrication Instructions .....   | 4-7  | 4-2  |
|          | V.     | Preventive Maintenance Checks and Services.....                          | 4-9  | 4-2  |
|          | VI.    | Troubleshooting .....  | 4-11 | 4-5  |
|          | VII.   | Radio Interference Suppression .....                                     | 4-12 | 4-13 |
|          | VIII.  | Overhead Guard and Floor Plate .....                                     | 4-16 | 4-15 |
|          | IX.    | Operator's Seat.....   | 4-19 | 4-16 |
|          | X.     | Body Panels and Hoods.....   | 4-21 | 4-18 |
|          | XI.    | Instrument Panel and Instruments.....                                    | 4-22 | 4-20 |
|          | XII.   | Hydraulic Lift Components .....  | 4-23 | 4-21 |
|          | XIII.  | Electrical System .....  | 4-30 | 4-29 |
|          | XIV.   | Fuel System.....   | 4-41 | 4-41 |
|          | XV.    | Cooling System.....  | 4-52 | 4-50 |
|          | XVI.   | Exhaust System.....  | 4-57 | 4-56 |
|          | XVII.  | Steering System .....  | 4-59 | 4-57 |
|          | XVIII. | Maintenance of Engine .....  | 4-62 | 4-60 |
|          | XIX.   | Wheels and Tires.....  | 4-69 | 4-64 |
|          | XX.    | Brakes .....   | 4-72 | 4-65 |
|          | XXII.  | Transmission .....   | 4-81 | 4-76 |
| APPENDIX | A.     | REFERENCES .....   | A-1  | A-1  |
| APPENDIX | B.     | MAINTENANCE ALLOCATION CHART.....  | B-1  | B-1  |
| APPENDIX | C.     | BASIC ISSUE ITEMS LIST AND ITEMS TROOP INSTALLED OR AUTHORIZED LIST..... | C-1  | C-1  |

INDEX

## LIST OF ILLUSTRATIONS

| Fig.<br>No. | Title  | Page |
|-------------|--|------|
| 1-1         | Fork List Truck, Right Side View (TS007668).....   | 1-2  |
| 1-2         | Fork List Truck, Left Side View (TS007669).....  | 1-3  |
| 1-3         | Wiring Diagram (TS007670).....   | 1-5  |
| 2-1         | Driving Controls and Instruments (TS007671).....   | 2-2  |
| 2-2         | Operation Controls and Instruments (TS007672).....   | 2-3  |
| 3-1         | Engine Crankcase Dipstick Location (TS007673).....   | 3-2  |
| 3-2         | Coolant Level Indicator (TS007674).....  | 3-2  |
| 3-3         | Transmission Dipstick Location (TS007675).....   | 3-3  |
| 4-1         | Interference Suppression Components, Removal and Installation, Sheet 1 (TS007676).....         | 4-14 |
| 4-1         | Interference Suppression Components, Removal and Installation, Sheet 2 (TS007676).....         | 4-15 |
| 4-2         | Overhead Guard and Floor Plate, Removal and Installation (TS007677).....                       | 4-16 |
| 4-3         | Operator's Seat (TS007665).....  | 4-17 |
| 4-4         | Body Panels and Hoods (TS007667).....  | 4-19 |
| 4-5         | Instrument Panel, Disassembly and Reassembly (TS007678).....                                   | 4-20 |
| 4-6         | Tilt-Lock Valve, Removal and Installation (TS007679).....                                      | 4-21 |
| 4-7         | Tilt Cylinder, Removal and Installation (TS007680).....  | 4-22 |
| 4-8         | Tilt Cylinder, Disassembly and Reassembly (TS007681).....                                      | 4-23 |
| 4-9         | Lift Chain, Removal and Installation (TS007682).....   | 4-24 |
| 4-10        | Checking Lift Chain Adjustment (TS007683).....   | 4-25 |
| 4-11        | Hydraulic Lines, Removal and Installation (TS007684).....                                      | 4-26 |
| 4-12        | Hydraulic Oil Filter, Disassembly and Reassembly (TS007685).....                               | 4-28 |
| 4-13        | Alternator Output Test Setup (TS007686).....   | 4-29 |
| 4-14        | Checking Field Relay (TS007687).....   | 4-30 |
| 4-15        | Voltage Regulator, Cover Removed (TS007688).....   | 4-31 |
| 4-16        | Cutout Relay Closing Voltage Test Circuit ITS007689).....                                      | 4-32 |
| 4-17        | Voltage Regulator Setting Test Circuit (TS007690).....   | 4-33 |
| 4-18        | Current Regulator Setting Test Circuit (TS007691).....   | 4-33 |
| 4-19        | Voltage Regulator, Removal and Installation (TS007692).....                                    | 4-34 |
| 4-20        | Starting Motor, Removal and Installation (TS007693).....                                       | 4-35 |
| 4-21        | Distributor, Disassembly and Reassembly (TS007694).....  | 4-36 |
| 4-22        | Checking Distributor Point Gap (TS007696).....   | 4-37 |
| 4-23        | Checking Spark Gap (TS007696).....   | 4-38 |
| 4-24        | Ignition Coil, Removal and Installation (TS007697).....  | 4-38 |
| 4-25        | Battery and Cables, Removal and Installation (TS007698).....                                   | 4-39 |
| 4-26        | Headlight, Disassembly and Reassembly (TS007699).....  | 4-40 |
| 4-27        | Taillight, Disassembly and Reassembly (TS007700).....  | 4-40 |
| 4-28        | Positive Crankcase Ventilation Valve and Piping (TS007701).....                                | 4-42 |
| 4-29        | Carburetor, Adjustment Points, Removal and Installation (TS007702).....                        | 4-43 |
| 4-30        | Fuel Filter, Fuel Pump, Lines and Fittings, Removal and Installation (TS007703).....           | 4-44 |
| 4-31        | Fuel Filter Service (TS007704).....  | 4-45 |
| 4-32        | Air Cleaner, Removal and Installation (TS007705).....  | 4-46 |
| 4-33        | Fuel Tank Lines and Fittings (TS007706).....   | 4-47 |
| 4-34        | Governor Adjustment (TS007707).....  | 4-48 |
| 4-35        | Accelerator Pedal and Linkage (TS007708).....  | 4-49 |
| 4-36        | Cooling System, Disassembly and Reassembly (TS007709).....                                     | 4-51 |
| 4-37        | Reverse Flushing the Radiator (TS007710).....  | 4-52 |
| 4-38        | Reverse Flushing the Engine Block (TS007711).....  | 4-52 |
| 4-39        | Fan and Alternator Belt Adjustment and Replacement, and Alternator Replacement (TS007712)..... | 4-54 |
| 4-40        | Water Pump and Fan Blade, Removal and Installation (TS007713).....                             | 4-55 |
| 4-41        | Exhaust System, Removal and Installation (TS007714).....                                       | 4-56 |
| 4-42        | Drag Link, Disassembly and Reassembly (TS007715).....  | 4-58 |
| 4-44        | Checking Engine Compression (TS007717).....  | 4-60 |

## LIST OF ILLUSTRATIONS-Continued

| Fig.<br>No. | Title   | Page |
|-------------|---|------|
| 4-47        | Engine Oil Filter, Removal and Installation (TS007720).....                           | 4-61 |
| 4-48        | Intake and Exhaust Manifold, Removal and Installation (TS007721).....                 | 4-63 |
| 4-49        | Wheel and Tire, Removal and Installation (TS007722).....                              | 4-64 |
| 4-50        | Wheel Bearings and Hub, Disassembly and Reassembly (TS007723).....                    | 4-65 |
| 4-51        | Parking Brake Adjustment Points (TS007724).....                                       | 4-66 |
| 4-52        | Hand Brake Lever, Removal and Installation (TA223477).....                            | 4-67 |
| 4-54        | Pressure Bleeding Setup (TS007727).....   | 4-70 |
| 4-55        | Brake System Bleed Points (TS007728).....   | 4-71 |
| 4-56        | Service Brake Master Cylinder, Removal and Installation (TS007729).....               | 4-72 |
| 4-57        | Inching Brake Master Cylinder, Removal and Installation (TS007730).....               | 4-73 |
| 4-58        | Brake Pedal and Linkage, Adjustment (TS007731).....                                   | 4-74 |
| 4-60        | Transmission Oil Filter, Lines and Fittings, Removal and Installation (TS007733)..... | 4-77 |
| 4-61        | Directional Shift Lever and Linkage (TS007734).....                                   | 4-78 |

Change 2 iii



**LIST OF TABLES**

| Table | Title  | Page |
|-------|--|------|
| 3-1   | Operator/Crew Preventive Maintenance Checks and Services.....                              | 3-1  |
| 3-2   | Freezing Points, Composition, and Specific Gravities of Military Antifreeze Materials..... | 3-2  |
| 3-3   | Troubleshooting.....   | 3-3  |
| 4-1   | Organizational Preventive Maintenance Checks and Services.....                             | 4-1  |
| 4-2   | Troubleshooting.....   | 4-2  |
| 4-3   | Temperature-Voltage and Temperature-Current Chart for Adjusting Voltage Regulator .....    | 4-3  |

## CHAPTER 1

## INTRODUCTION

## Section I. GENERAL

**1-1. Scope**

This manual is for your use in operating and maintaining the Army Model MHE-229 Fork Lift Truck.

**1-2. Maintenance Forms and Records**

Maintenance forms and records that you are required to use are: DA Form 2408 (Equipment Log Assembly-Records), DA Form 2408-1 (Equipment Daily and Monthly Log), DA Form 2408-5 (Equipment Modification Record), DA Form 2408-9 (Equipment Control Record), DA Form 2408-10 (Equipment Component Register), and DA Form 2408-14 (Uncorrected Fault Record).

**1-3. Reporting Errors and Recommending Improvements**

You can help improve this manual. If you find any mistakes or if you know of a way to improve the procedures, please let us know. Mail your letter or DA Form 2028 (Recommended Changes to Publications and Blank Forms) direct to: Commander, US Army Tank-Automotive Command, ATTN: DRSTA-MB, Warren, MI 48090. A reply will be furnished to you.

**1-4. Equipment Serviceability Criteria**

This equipment is not covered by an ESC.

**1-5. Destruction of Army Materiel to Prevent Enemy Use**

*a. General.* Do not destroy the truck except on order of proper authority, and demolish it only to prevent capture

and use of the truck by the enemy. Destroy the same parts on all similar equipment to prevent enemy use through cannibalization.

*b. Methods.*

(1) *Controls.* Smash all controls, including steering wheel.

(2) *Gasoline Engine.* Pierce or smash cylinder block. Damage crankshaft and camshaft.

(3) *Transmission and Differential.* Pierce or smash transmission and differential case.

(4) *Steering Gear.* Pierce or smash steering gear housing.

(5) *Wires, Cables, and Lines.* Cut, rip out, or otherwise destroy all wires, electrical cables, and fuel, oil, or water lines.

(6) *Carburetor and Manifolds.* Smash these assemblies.

(7) *Alternator, Distributor, Ignition Coil and Spark Plugs.* Destroy these components by smashing.

(8) *Radiator.* Drive large holes through core and tank. Break off drain cock.

(9) *Battery.* Break case and plates of battery.

**1-6. Administrative Storage**

Preparation, care, and removal of equipment in administrative storage will be in accordance with the applicable requirements of TM 740-90-1 (Administrative Storage of Equipment).

## Section II. DESCRIPTION AND DATA

**1-7. Description**

*a. General.* The fork lift truck (fig. 1-1 and 1-2) is a four cylinder gasoline engine driven, torque converter coupled, solid rubber tire-mounted unit. The fork lift truck utilized hydraulic power for its lift and tilt functions.

The truck has a rated capacity of 2000 pounds and is designed for high maneuverability and operation in confined areas. The maintenance paragraphs of this manual contain detailed descriptions of the various components of the truck.

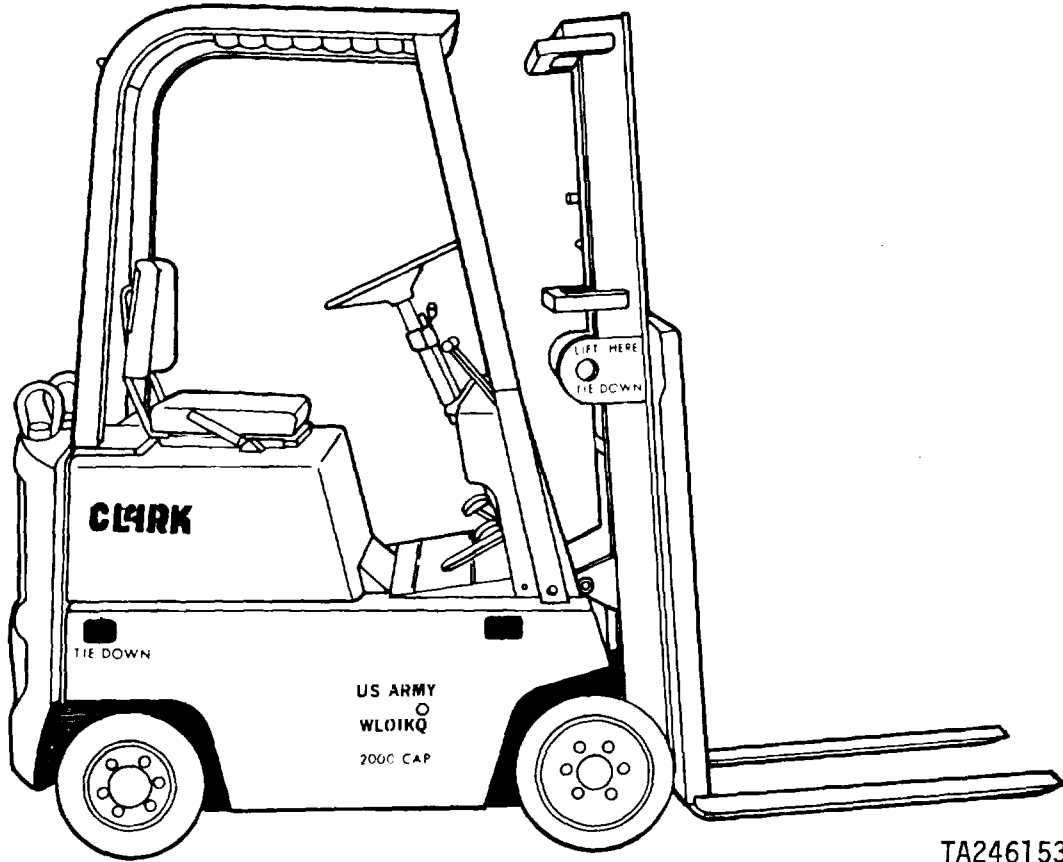

TA246153

Figure 1-1. Fork Lift Truck, Right Side View

Change 1 1-2

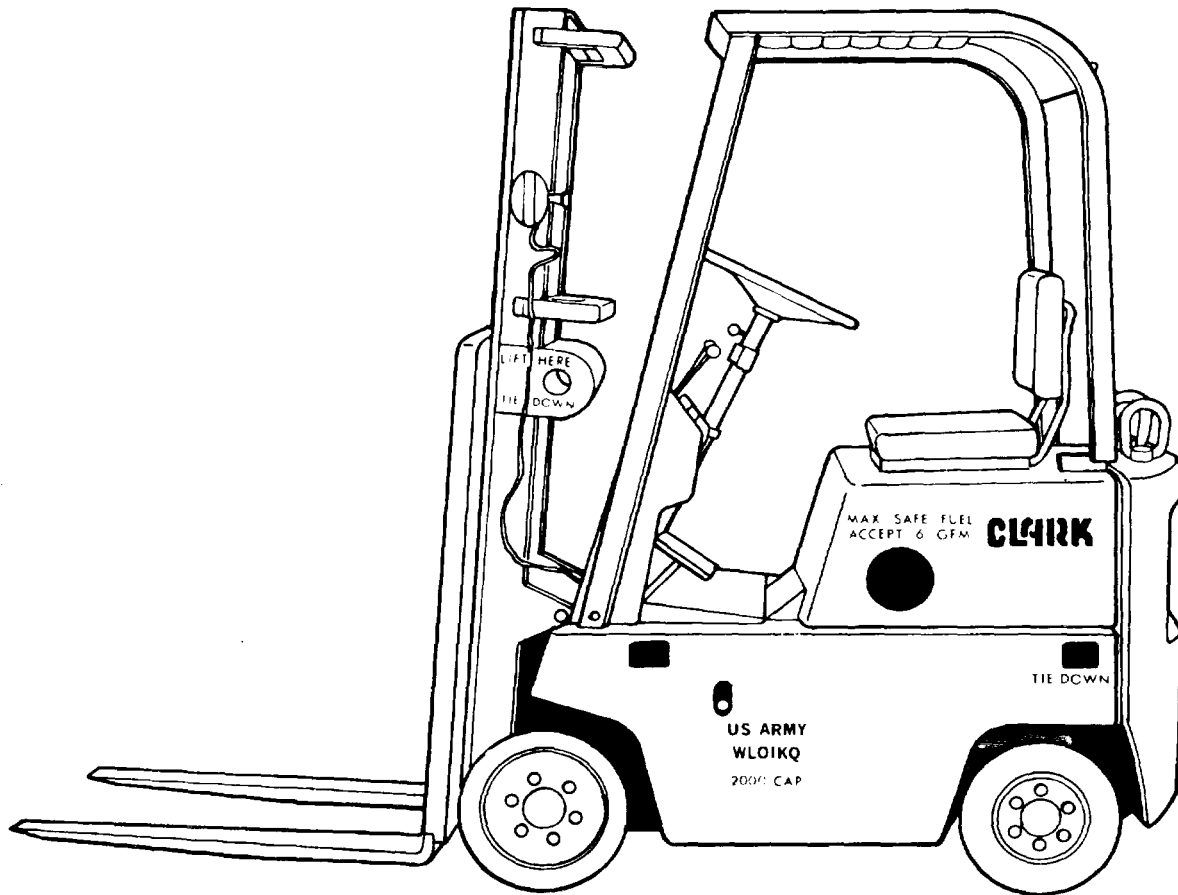

TA246154

Figure 1-2. Fork Lift Truck, Left Side View

**1-8. Tabulated Data**

a. *Identification.* The fork lift truck has one identification plate, located on a panel in front of the driver's compartment. It specifies model, serial number, registration number, federal stock number, engine serial number, warranty data, shipping and inspection dates, contract number, capacity, gross vehicle weight and dimensional information.

b. *Tabulated Data.*

(1) Identification plate

Model .....C500-20  
 Serial number.....1 thru 519  
 Registration number  
 National stock number.....3930-00-315-9699  
 Contract number .....DSA 700-73-C-9423  
 Capacity .....2000 lb  
 G.V.W.....4730 lb  
 Length .....69.5 in.  
 Height.....81.5 in.  
 Shipping weight  
 Width .....33.5 in.

(2) Fork lift truck

Manufacturer..... Clark Equipment Co.  
 Model .....2329397  
 Serial number range..... 1 thru 519

(3) Engine

Manufacturer..... Teledyne Continental  
 Motors  
 Model .....Y112-8061  
 Cylinders.....4-in line  
 Bore and stroke.....3-3/16 X 3 1/2 in.  
 Displacement (cu in.)..... 112  
 Compression ratio.....6.07:1  
 Max. oil pressure..... 30-40 PSI  
 Min. oil pressure (idling).....7 PSI  
 Firing order .....1-3-4-2  
 Main bearing front .....1 3/4 X 1-7/32 in.  
 Main bearing center .....1 3/4 X 1-7/16 in.  
 Main bearing rear .....1 3/4 X 1-7/16 in.  
 Crankcase oil capacity .....3 1/2 qt  
 Filter oil capacity .....1/2 qt  
 Total oil capacity .....4 qt  
 Intake valve clearance......012 in.

Exhaust valve clearance .....020 in.  
 Engine water capacity .....3 ¼ qt  
 Engine and radiator water  
 capacity ..... 15 qt  
 Weight (bare engine).....290 lb

(4) Engine alternator

Manufacturer.....Delco-Remy Div.,  
 General Motors Corp.  
 Part number ..... 1100720

(5) Engine starter

Manufacturer.....Delco-Remy Div.,  
 General Motors Corp.  
 Part number ..... 1107378

(6) Voltage regulator

Manufacturer.....Delco-Remy Div.,  
 General Motors Corp.  
 Part number ..... 1119507

(7) Distributor

Manufacturer.....Delco-Remy Div.,  
 General Motors Corp.  
 Part number ..... 1112637  
 Point gap (inches) .....0.022  
 Spark plug gap (inches) .....0.030

(8) Transmission

Manufacturer.....Clark Equipment Co.  
 Part number .....284427

(9) Wheels and tires

Drive wheels:  
 Tire size ..... 16X6X10.5  
 Type..... Solid  
 Steer wheels:  
 Tire size ..... 14X4.5X8  
 Type..... Solid

(10) Performance

Lift height max..... 128.25 in.  
 Load capacity ..... 2000 lb  
 Lift speed:  
 Lift loaded ..... 69 FPM  
 Lift empty ..... 79 FPM  
 Lower loaded..... 80 FPM  
 Lower empty ..... 76 FPM  
 Travel speed:  
 Forward empty ..... 8.6 MPH  
 Forward loaded ..... 8.5 MPH  
 Reverse empty..... 8.7 MPH  
 Reverse loaded ..... 8.6 MPH  
 Wheel loadings (each):  
 Drive wheels:  
 No load ..... 1123 lb  
 Full load ..... 2912 lb  
 Steer Wheels:  
 No load ..... 1243 lb  
 Full load ..... 453 lb  
 Turning radius..... 62.0 in.  
 Basic right angle stacking .. 72.75 in. + load length  
 Upright tilt:  
 Forward..... 3°  
 Back..... 10°

(11) Electrical wiring. Refer to figure 1-3.

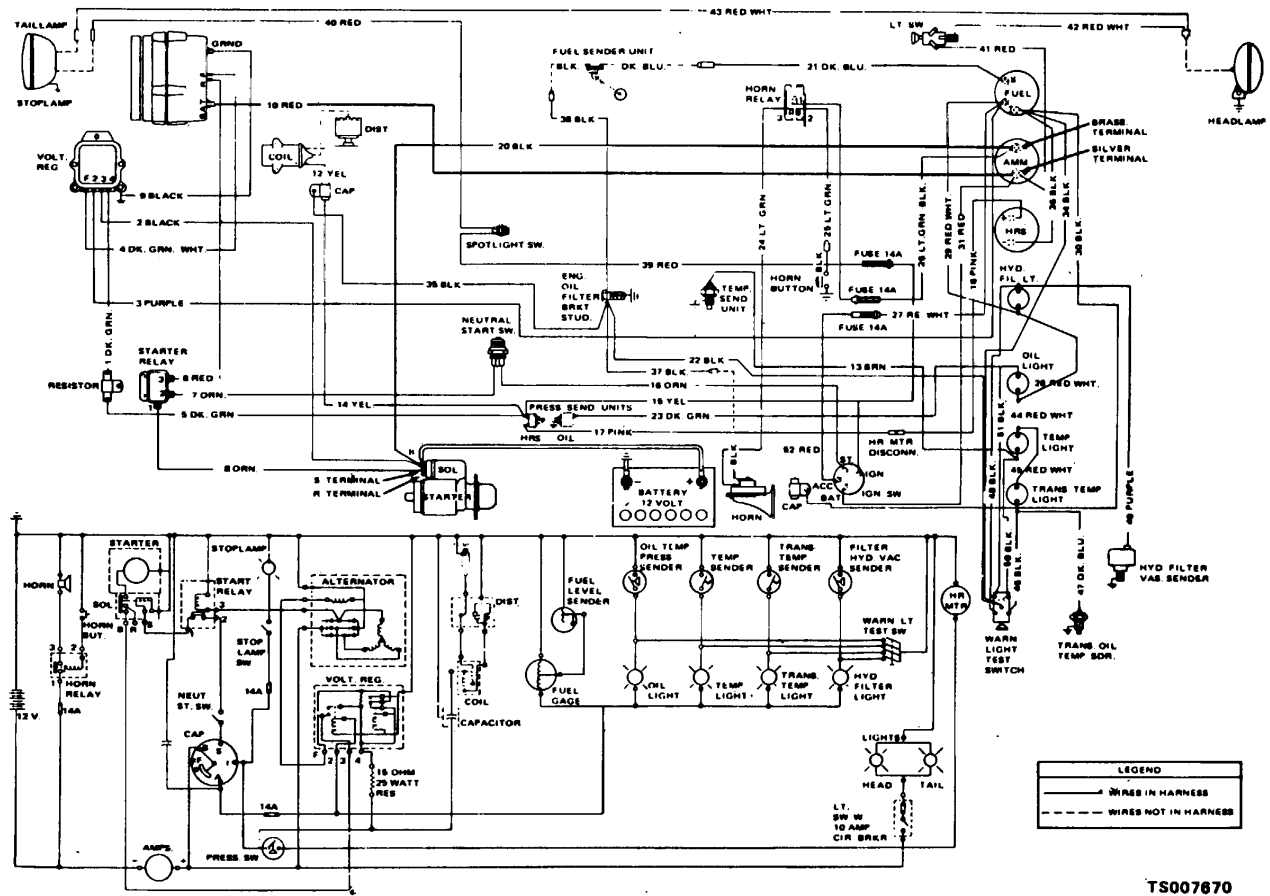

Figure 1-3. Wiring Diagram

**1-9. Differences in Models**

This manual covers the Army Model MHE-229 Fork Lift Truck, (Clark Equipment Model 2329397). No

differences exist in the units delivered under this contract.

## CHAPTER 2

## OPERATING INSTRUCTIONS

## Section I. OPERATING PROCEDURES

**2-1. General**

This section contains instructions for operating the fork lift truck under normal conditions. Detailed instructions are given to fully acquaint the operator with specific procedures of each function which the fork lift truck is capable of performing. Since different tasks present varying problems, the operator may have to alter any given procedure to suit the individual situation.

**NOTE**

If equipment fails to operate, refer to troubleshooting procedures in Chapter 3.

**2-2. Starting***a. Preparation for Starting.*

(1) Perform the before-operation services (table 3-1).

(2) Insure that the truck is properly lubricated as specified in the Lubrication Order LO 10-3930-632-12.

**NOTE**

Prior to attempting any operation of the truck, the operator should thoroughly familiarize himself with all controls and instruments and their respective locations.

*b. Starting.* Refer to figure 2-1 and start the truck in the following manner:

(1) Pull up on parking brake lever to make sure it is fully engaged.

(2) Check that direction control lever is in

N  
(neutral) position.

(3) If engine is cold, pull choke control fully out.

(4) Press and hold accelerator pedal one-third of way to floor.

(5) Turn starter and ignition switch fully clockwise to START. Hold until engine starts, then release.

(6) Hold accelerator at one-third application, allowing engine to warm up at fast idle.

**CAUTION**

Do not operate starter motor continuously for more than 30 seconds. If engine fails to start within that time, allow starting motor to cool 2 minutes before attempting to start again.

(7) Check engine oil pressure light and ammeter. They must show normal readings.

(8) As engine warms up, push in choke just enough to maintain smooth operation until it is fully in.

**CAUTION**

Long periods of idling are detrimental to the engine and waste gasoline. Shut off the engine when the truck is not being operated.



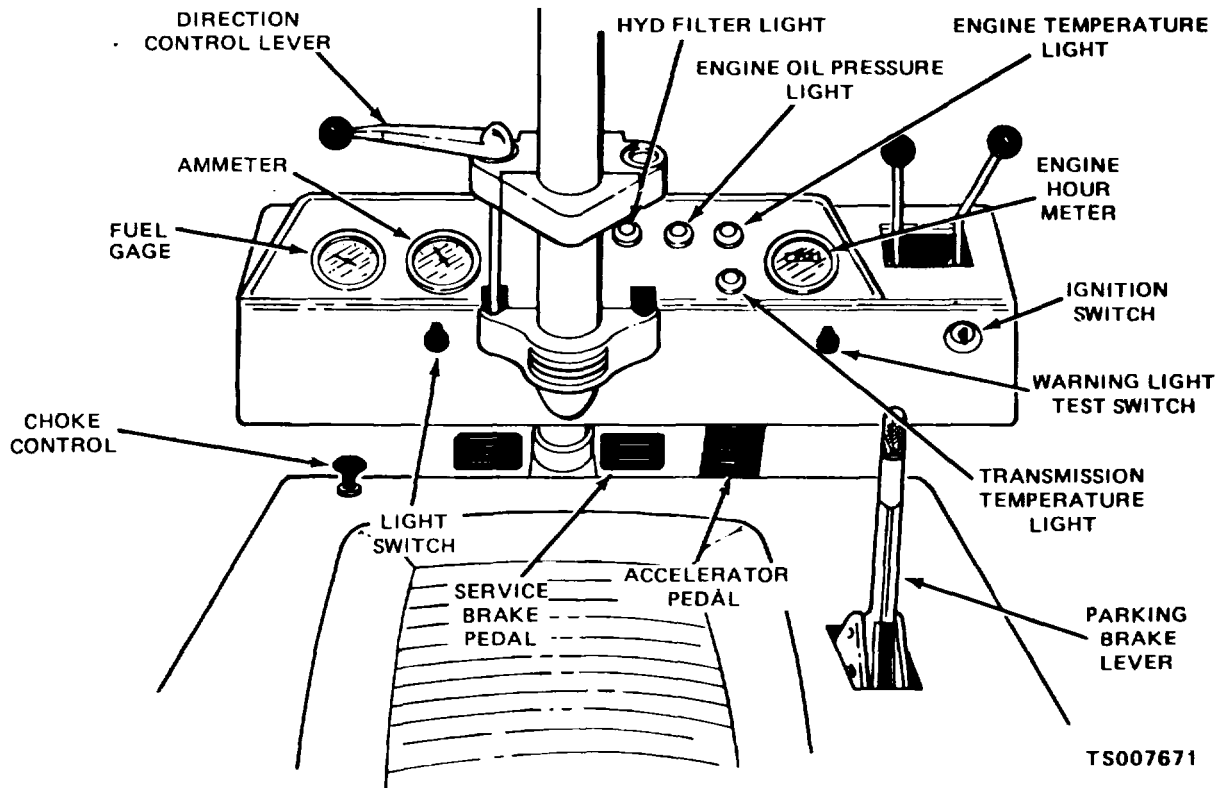

Figure 2-1. Driving Controls and Instruments

**2-3. Stopping**

a. Refer to figure 2-2 and to the following procedures for stopping the truck.

- (1) If truck is in motion, remove foot from accelerator and apply gradual pressure to brake pedal to stop truck.
- (2) Apply parking brake by pulling up lever.
- (3) Shift direction shift lever to N (neutral) position.
- (4) Operate load tilt control lever to bring upright to vertical position.

(5) Operate load lift control lever forward to lower forks to ground.

(6) Turn starter and ignition to OFF position.

**NOTE**

If engine has been running hard, it is good practice to operate the engine at fast idle for several minutes without load to allow engine heat to dissipate, preventing engine parts from warping when it is shut down.

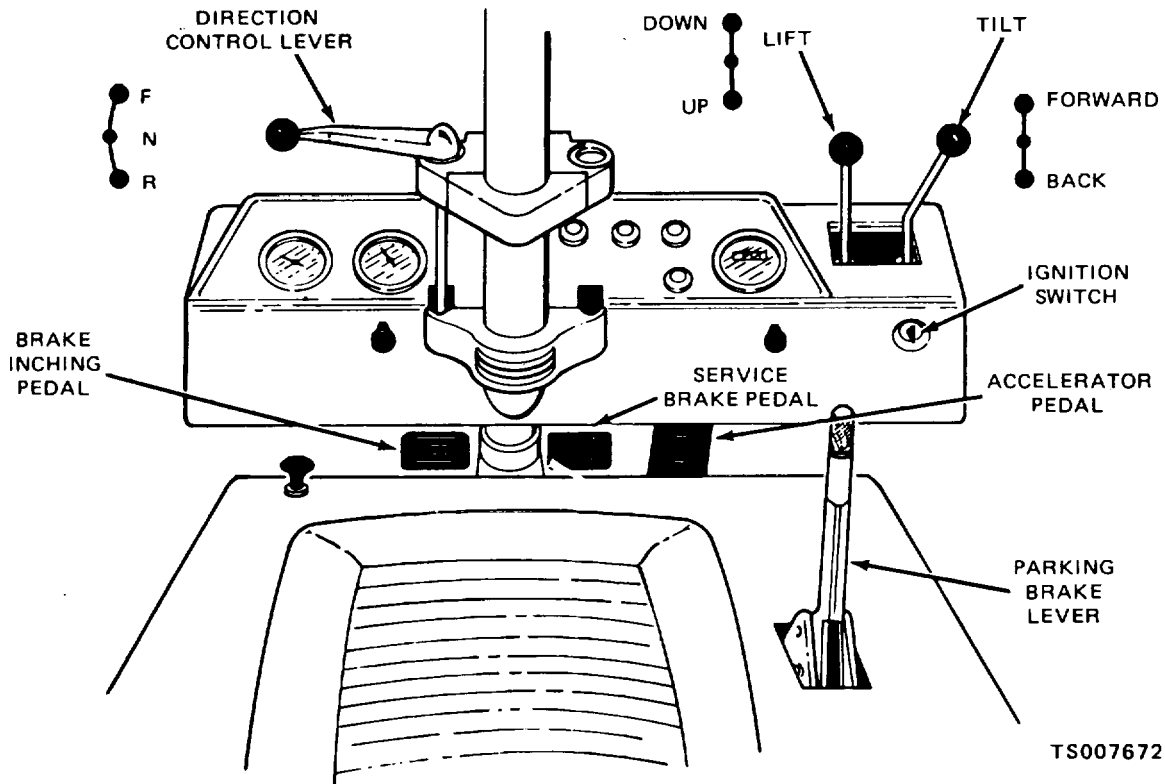

Figure 2-2. Operation Controls and Instruments

#### 2-4. Driving Truck

a. Start the engine (para 2-2). Accelerate the engine slightly and move the lift control lever (fig. 2-2) up and raise the forks to normal traveling position (approximately 8 to 10 inches above the working surface).

b. Move the control lever back and tilt forks toward the rear.

c. Move the direction shift lever from N (neutral) position to F (forward) or R (reverse) position, depending upon the desired direction of travel.

d. Place foot on the accelerator pedal and release the parking brake lever. Gradually depress the accelerator pedal until the truck begins to travel. Continue to depress the accelerator pedal until safe operating speed is attained. If the truck fails to move, shut off the engine immediately and report this to organizational maintenance.

#### CAUTION

Keep foot off brake pedal except for stopping and inching operations. Riding the brake pedal while traveling will result in transmission overheating and wear caused by slipping of selector clutch packs.

#### 2-5. Picking Up Load

a. Approach the load squarely and halt the truck. Move the tilt control lever (fig. 2-2) forward and bring the mast assembly to the vertical position. Raise or lower the forks to the proper height to pick up the load.

b. Move the truck forward until the forks are positioned under the load. Make certain the forks are fully inserted in the pallet or under the load.

c. Apply and hold the brake to prevent the truck from shifting position during the lifting operation.

d. Move the direction lever (fig. 2-2) to N (neutral).

e. Move the lift control lever to the rear and accelerate the engine to raise the load approximately 12 inches above ground level. Release the lift control lever. Move the tilt control lever backward to tilt the forks backward. Release the lever and decelerate the engine.

f. Move the direction shift lever from N (neutral) position to the proper position for the desired direction of travel.

g. Release the brake, depress the accelerator pedal, and move the load to the desired location.

**CAUTION**

Do not keep the lift carriage-loaded or unloaded-elevated for long periods. Always lower the load to the ground during waiting periods. Do not hold hydraulic control levers in operating positions after limit of travel has been reached. This will result in overheating of the hydraulic fluid.

**2-6. Driving With a Load**

a. For maximum stability of load and truck, drive with load as low as possible, still maintaining floor clearance.

b. Tilt mast column back.

c. Drive forward on upgrades, and drive in reverse for downgrades.

d. For better vision, drive backwards with bulky loads.

**2-7. Depositing Load**

a. *Depositing Load on Tiered Stack.*

(1) Move the lift control lever to the rear and accelerate the engine until the load reaches the desired height above the tier.

(2) Drive the truck forward until the load is above its resting place. To slowly maneuver the truck forward, use the inching pedal. High engine speed is needed for this operation.

(3) Apply and hold the brake.

(4) Move the direction shift lever to N

(neutral position). Move the tilt control lever forward to tilt the forks forward until the load is aligned with tier.

(5) Move the lift control lever forward and carefully lower the load into position on the tier. Continue to lower the forks until they can be easily withdrawn from the pallet.

(6) Move the direction shift lever to R (reverse) position. Release the brake and slowly back the truck away from the tiered stack until the forks are clear.

(7) Move the lift control lever forward to lower the forks into normal traveling position (8 to 10 inches above surface).

b. *Depositing Load in Storage Area.*

(1) Carefully drive up to the position at which the load is to be deposited. Depress the braking and inching pedal (fig. 2-2) to halt the truck.

(2) Maintain brake pressure and move the direction shift lever (fig. 2-2) to N (neutral) position.

(3) Move the tilt control lever forward and bring the mast assembly to the vertical position.

(4) Move the lift control lever forward and carefully lower the load to the ground. Continue to lower the forks until they can be easily withdrawn from the load.

(5) Place the direction shift lever in R (reverse) position. Release the brake and slowly back the truck away from the deposited load.

**Section II. OPERATION UNDER UNUSUAL CONDITIONS****2-8. Operation in Extreme Cold (Below 0°F (-18 C))**

a. Make sure the antifreeze solution is correct for the lowest temperature expected. See table 3-2.

b. Inspect the cooling system. Correct or report any leaks.

c. Keep batteries fully charged. After adding water to batteries, run the engine for at least one hour.

d. Keep fuel tank full when not in operation.

e. Drain and service the fuel filter (para 4-26).

f. Lubricate in accordance with the Lubrication

Order LO 10-3930-632-12.

g. Allow the engine to reach normal operating temperature before applying load.

**2-9. Operation in Extreme Heat**

a. Maintain the required coolant level in the radiator.

b. Check fan belt tension frequently to assure that there is no belt slippage. Belt slippage decreases the efficiency of the fan and water pump. Refer to paragraph 4-38 for belt tightening adjustment.

c. Keep external parts of the radiator clean and free from foreign matter which could restrict heat transfer and air flow.

d. Check the battery electrolyte level frequently to assure that it is at required level. Add distilled or demineralized water to the tops of the split rings, if necessary.

**2-10. Operation in Sandy or Dusty Areas**

a. Service the engine air cleaner and the crankcase breather more frequently to keep dust and dirt from entering the engine.

b. Increase the frequency of service of the fuel filter.

c. Keep sand from collecting around axles, steering spindles, and brakes.

d. Wipe sand and dirt from exposed lift and tilt cylinder piston rods. Sand is highly abrasive and will cause excessive wear of the mechanical parts.

e. When parking the truck, park it in an enclosed building or cover it with a tarpaulin if an enclosed building is not available.

#### **2-11. Operation in Salt Water Areas**

a. Protect all exposed metal surfaces from rust and corrosion. Apply grease or oil frequently.

b. Immediately touch up all chipped and deteriorated paint.

c. If the fork lift truck is splashed or otherwise subjected to direct application of salt water, wash it off immediately with fresh water and dry thoroughly.

d. Take extra care to prevent rust and corrosion of the exposed piston rods of the lift and tilt cylinders.

#### **2-12. Operation in High Altitude Areas**

Because of the decreased supply of oxygen at high altitudes, engines operate less efficiently. Take special care to assure that the air cleaner is properly serviced to provide the highest efficiency possible during the high altitude operation.

## CHAPTER 3

## OPERATOR/CREW MAINTENANCE INSTRUCTIONS

## Section I. LUBRICATION INSTRUCTIONS

**3-1. General Lubrication Information**

a. This paragraph contains lubrication instructions which are supplemental to, and not specifically covered in, the Lubrication Order LO 10-3930-632-12.

b. Use only the lubricants specified in the lubrication order. Carefully follow instructions given on the lubrication order to assure proper operation of the equipment.

**3-2. Detailed Lubrication Information**

a. *General.* Keep all lubricants in closed containers and store in a clean, dry place away from external heat. Allow no dust, dirt, or other foreign

material to mix with the lubricants. Keep all lubrication equipment clean and ready for use.

b. *Cleaning.* Keep all external parts not requiring lubrication clean of lubricants. Before lubricating the equipment, wipe all lubrication points free of dirt or grease. Clean all lubrication points after lubrication to prevent accumulation of foreign matter.

c. *Points of Lubrication.* Service the lubrication points at proper intervals as illustrated in the lubrication order.

## Section II. OPERATOR/CREW PREVENTIVE MAINTENANCE CHECKS AND SERVICES

**3-3. General**

Preventive maintenance is detecting/correcting problems before they happen, or fixing little problems before they become big problems. Table 3-1 contains a list of preventive maintenance checks and services to be performed by operator/crew. Attention to these checks and services will increase the useful life of the fork lift truck, but every possible problem cannot be covered in the PMCS. You need to be alert for anything that might cause a problem.

**3-3.1. Maintenance Forms and Records.**

Every mission begins and ends with the paperwork. There isn't much of it, but you have to keep it up. The forms and records you fill out have several uses. They are a permanent record of the services, repairs, and modifications made on your equipment. They are reports to organizational maintenance and to your commander. And they are a checklist for you when you want to know what is wrong with the equipment after its last use, and whether those faults have been fixed. For the information you need on forms and records, see TM 38-750.

**3-4. Preventive Maintenance Checks and Services**

a. Do your (B) PREVENTIVE MAINTENANCE just before you operate the equipment. Pay attention to the CAUTIONS and WARNINGS.

b. Do your (D) PREVENTIVE MAINTENANCE during operation. (During operation means to monitor the fork lift truck while it is actually being used).

c. Do your (A) PREVENTIVE MAINTENANCE right after operating the equipment. Pay attention to the CAUTIONS and WARNINGS.

d. Do your (W) WEEKLY PREVENTIVE MAINTENANCE weekly.

e. Do your (M) MONTHLY PREVENTIVE MAINTENANCE once a month.

f. If something doesn't work, troubleshoot it with the instructions in this manual or notify your supervisor.

g. Always do your PREVENTIVE MAINTENANCE in the same order, so it gets to be a habit. Once you've had some practice, you'll spot anything wrong in a hurry.

h. If anything looks wrong and you can't fix it, write it on your DA Form 2404. If you find

something seriously wrong, report it to organizational maintenance RIGHT NOW.

i. When you do your PREVENTIVE MAINTENANCE, take along the tools you need to make all the checks. You always need a rag or two.

**WARNING**

Drycleaning solvent SD-2, used to clean parts, is potentially dangerous to personnel and property. Do not use near open flame or excessive heat. Flash point of solvent is 138°F.

(1) *Keep it clean.* Dirt, grease, oil, and debris only get in the way and may cover up a serious problem. Clean as you work and as needed. Use drycleaning solvent (SD-2) to clean metal surfaces. Use soap and water when you clean rubber or plastic material.

(2) *Bolts, nuts, and screws.* Check them all for obvious looseness, missing, bent, or broken condition. You can't try them all with a tool, of course. But look for chipped paint, bare metal, or rust around bolt heads. If you find one you think is loose, tighten it or report it to organizational maintenance.

(3) *Welds.* Look for loose or chipped paint, rust, or gaps where parts are welded together. If you find a bad weld, report it to organizational maintenance.

(4) *Electric wires and connectors.* Look for cracked or broken insulation, bare wires, and loose or broken connectors. Tighten loose connectors and make sure the wires are in good shape.

(5) *Hoses and fluid lines.* Look for wear, damage, and leaks, and make sure clamps and fittings are tight. Wet spots show leaks, of course, but a stain around a fitting or connector can mean a leak. If a leak

comes from a loose fitting or connector, tighten it. If something is broken or worn out, report it to organizational maintenance.

j. It is necessary for you to know how fluid leakage affects the status of your equipment. The following are definitions of the types/classes of leakage you need to know to be able to determine the status of your equipment. Learn, then be familiar with them and REMEMBER-WHEN IN DOUBT, NOTIFY YOUR SUPERVISOR! Leakage definitions for Operator/Crew PMCS.

CLASS I Seepage of fluid (as indicated by wetness or discoloration) not great enough to form drops.

CLASS II Leakage of fluid great enough to form drops but not enough to cause drops to drip from item being checked/inspected.

CLASS III Leakage of fluid great enough to form drops that drip from the item being checked/inspected.

**CAUTION**

Equipment operation is allowable with minor leakage (Class I or II). Of course, consideration must be given to the fluid capacity in the item/system being checked/inspected. When in doubt, notify your supervisor.

When operating with Class I or II leaks, continue to check fluid levels as required in your PMCS. Class III leaks should be reported to your supervisor or to organizational maintenance.

Table 3-1. Operator/Crew Preventive Maintenance Checks and Services

| ITEM NO. | Interval |   |   |   |   | ITEM TO BE INSPECTED<br>PROCEDURE: Check for and have repaired, filled or adjusted as needed.   | Equipment is not ready/<br>AVAILABLE IF:                       |
|----------|----------|---|---|---|---|---|--|
|          | B        | D | A | W | M |   |  |
| 1        |          |   |   |   |   | <p><i>IMPORTANT: PERFORM WEEKLY AS WELL AS BEFORE OPERATIONS PMCS IF:</i></p> <p>1. YOU ARE THE ASSIGNED OPERATOR AND HAVE NOT OPERATED THE ITEM SINCE THE LAST WEEKLY.<br/>2. YOU ARE OPERATING THE ITEM FOR THE FIRST TIME.</p> <p><i>EXTERIOR OF VEHICLE</i></p> <p>A. Check for leaks or appearance of leaks.<br/>B. Visually check overhead guard for obvious cracks in welds.</p> | Class III leaks or any fuel leaks.<br>Obvious cracks in welds. |
| 2        | •        |   |   |   |   | <p><i>AIR CLEANER</i></p> <p>Check and clean air cleaner element as necessary.<br/>Have Organizational Maintenance replace as necessary.</p>  |  |
| 3        | •        |   |   |   |   | <p><i>ENGINE OIL LEVEL (fig. 3-1)</i></p> <p>Check oil dipstick, add oil, if needed, to raise level to the full (F) mark.</p>   |  |

Table 3-1. Operator/Crew Preventive Maintenance Checks and Services - Continued

| ITEM NO. | Interval |   |   |   |   | ITEM TO BE INSPECTED<br>PROCEDURE: Check for and have repaired, filled or adjusted as needed.  | Equipment is not ready/<br>AVAILABLE IF:   |
|----------|----------|---|---|---|---|--|--|
|          | B        | D | A | W | M |  |  |
| 4        |          | • |   |   |   | <b>LIGHTS</b><br>Check that lights are working.  |  |
| 5        |          | • |   |   |   | <b>BRAKES</b><br>Check that normal brake pressure stops truck.   | Service brake will not stop truck.   |
| 6        |          | • |   |   |   | <b>STEERING</b><br>Check that truck steers free and easy.  | Steering sticks or truck is hard to steer.   |
| 7        |          | • |   |   |   | <b>ACCELERATOR</b><br>Check that truck accelerates smoothly.   | Pedal sticks.  |
| 8        |          | • |   |   |   | <b>HYDRAULIC CONTROLS</b><br>A. Check that lifting and lowering is smooth.<br><br>B. Forward and backward tilt is smooth and immediate.  | Lifting or lowering jerky or uncontrollable.<br>Tilt does not operate.                     |
| 9        |          | • |   |   |   | <b>INSTRUMENT PANEL</b><br>A. Check warning lights by operating warning light test switch. Have defective bulbs replaced by Organizational Maintenance.<br>B. During normal operation the warning lights should not be on. These lights include oil pressure, water temperature, transmission temperature, and hydraulic filter.<br>C. Check ammeter does not register discharge when engine is operated above idle speed. | Any warning lights is on.<br><br>Ammeter registers discharge with engine above idle speed. |
| 10       |          | • |   |   |   | <b>HORN</b><br>Check horn by pressing button.  |  |
| 11       |          |   |   | • |   | <b>TIRES</b><br>Check tires for wear, cracks, gouges, and chunking.  |  |
| 12       |          |   |   | • |   | <b>RADIATOR (fig. 3-2)</b><br>Check coolant level reaches tab inside filler neck approximately 2-3/4 inches below top of neck. Add coolant as necessary using proper mixture of water and antifreeze (reference TB 750-651).   |  |
| 13       |          |   |   |   | • | <b>BATTERY</b><br><br><b>WARNING</b><br>Do not smoke or allow any flame or spark in the vicinity while checking or filling the battery. The battery generates hydrogen, a highly explosive gas.<br>a. Inspect for electrolyte level, add distilled water to split ring if required (reference TM 9-6140-200-14).<br>b. Check battery posts and terminals for corrosion and ensure the connections are tight.               | Battery cracked or discharged.   |
| 14       |          |   |   |   | • | <b>HYDRAULIC RESERVOIR</b><br>Lower mast and have all cylinders retracted. Check reservoir fluid level on dipstick, add oil, if needed, to raise level to FULL mark.   |  |
| 15       |          |   |   |   | • | <b>FANBELT</b><br>Inspect for looseness or frayed condition.   |  |
| 16       |          |   |   |   | • | <b>RADIATOR ENGINE COMPARTMENT</b><br>Inspect and clean air passages in radiator.  |  |
| 17       |          |   |   |   | • | <b>TRANSMISSION OIL (fig. 3-3)</b><br>Check fluid level on dipstick on filler cap on axle housing. Add transmission fluid as necessary to bring level up to FULL mark on dipstick.   | Belt slips.  |

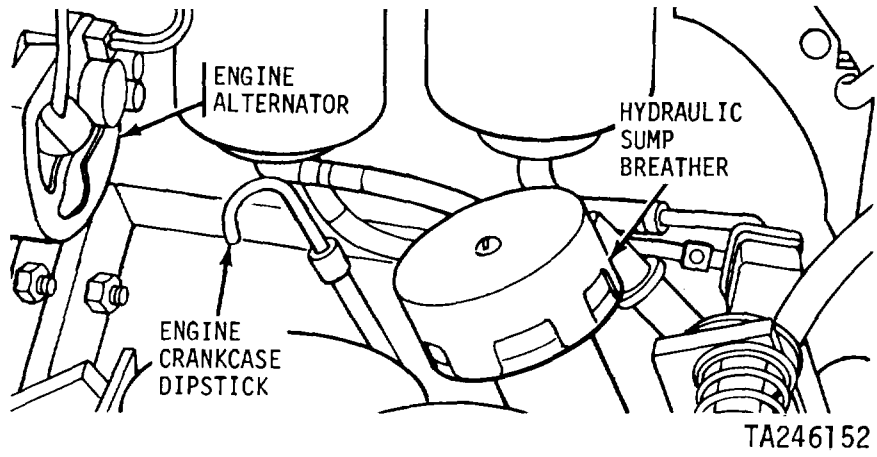

Figure 3-1. Engine Crankcase Dipstick Location

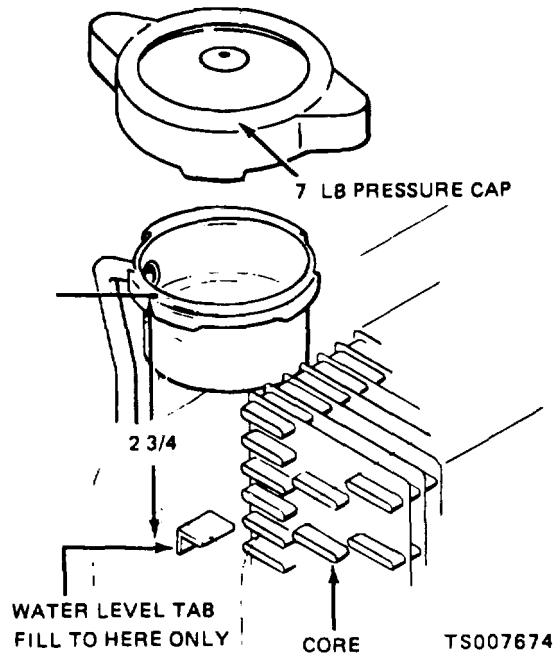

Figure 3-2. Coolant Level Indicator

Change 1 3-2.2



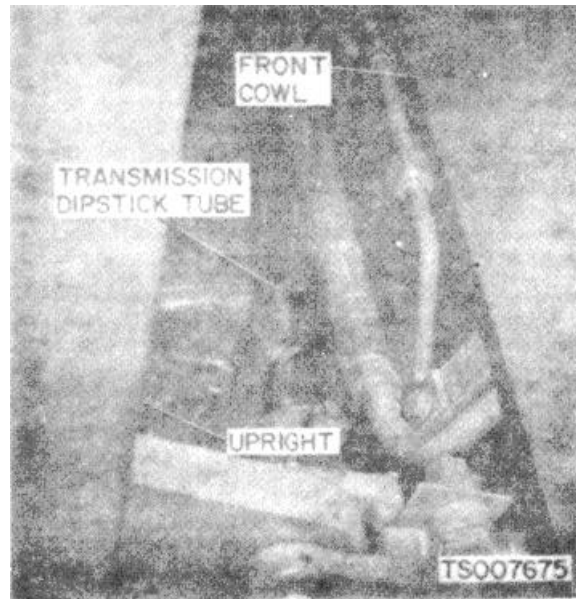

Figure 3-3. Transmission Dipstick Location

Table 3-2. Freezing Points, Composition, and Specific Gravities of Military Antifreeze Materials

| Lowest expected ambient temp. °F | Pints of inhibited glycol per gal. of coolant <sup>1</sup> | Compound antifreeze Arctic <sup>2</sup>  | Ethylene glycol coolant solution specific gravity at 68 °F <sup>3</sup> |
|----------------------------------|--|--|---|
| +20                              | 1 ½  | Issued full strength and ready mixed for 0° to -65°F temperatures for both initial installation and replenishment of losses. | 1.022   |
| +10                              | 2  |  | 1.036   |
| 0                                | 2 ¾  |  | 1.047   |
| -10                              | 3 ¼  |  | 1.055   |
| -20                              | 3 ½  |  | 1.062   |
| -30                              | 4  |  | 1.067   |
| -40                              | 4 ¼  | DO NOT DILUTE WITH WATER OR ANY OTHER SUBSTANCE  | 1.073   |
| -50                              | Arctic anti-freeze preferred                               |  |   |
| -60                              |  |  |   |
| -72                              |  |  |   |

<sup>1</sup> Maximum protection is obtained at 60 percent by volume (4.8 pints of ethylene glycol per gallon of solution).

<sup>2</sup> Military Specification MIL-C-11755 Arctic type, nonvolatile antifreeze compound is intended for use in the cooling system of liquid-cooled internal combustion engines. It is used for protection against freezing primarily in Arctic regions where the ambient temperature remains for extended periods close to -40 °F or drops below, to as low as -90 °F.

<sup>3</sup> Use an accurate hydrometer. To test hydrometer, use 1 part ethylene glycol antifreeze to 2 parts water. This should produce a hydrometer reading of 0° FF.

NOTE

Fasten a tag near the radiator filler cap indicating the type antifreeze.

### Section III. TROUBLESHOOTING

#### 3-5. General

a. This section contains troubleshooting information for locating and correcting most of the operating troubles which may develop in the fork lift

truck. Each malfunction for an individual component, unit, or system is followed by a list of tests or inspections which will help to determine probable causes and corrective actions to take.

You should perform the tests/inspections and corrective actions in the order listed.

b. This manual cannot list all malfunctions that may occur, nor all tests or inspections and corrective

actions. If a malfunction is not listed or is not corrected by listed corrective actions, notify your supervisor. (See table 3-3.)

Table 3-3. Troubleshooting

| MALFUNCTION  | TEST OR INSPECTION   | CORRECTIVE ACTION   |
|--|--|---|
| <b>ENGINE</b>  |  |   |
| 1. ENGINE FAILS TO CRANK WHEN KEY IS TURNED FULLY CLOCKWISE. | Step 1. Check to see if the battery electrolyte level is above the battery plates. | If electrolyte level is below top of plates, add distilled water to bring level to ¼ to ½ inch over top of plates.                        |
|  | Step 2. Inspect for loose or corroded battery post/cable connections.              | Clean corroded cables/posts. Tighten connections at battery, ground and starter. If cables are broken, notify organizational maintenance. |
| 2. ENGINE CRANKS BUT FAILS TO START.                         | Step 1. Check fuel gage for low or empty fuel tank indication.                     | Refill fuel tank if low or empty.   |
| <b>FUEL TANK</b>   |  |   |
| 1. FUEL DOES NOT REACH CARBURETOR.                           | Step 1. Check for low fuel.  | Fill fuel tank if low or empty.   |
|  | Step 2. Fuel tank cap vent clogged.  | Clean vent.   |
| <b>BATTERY</b>   |  |   |
| 1. BATTERY DISCHARGED.                                       | Step 1. Check for low battery electrolyte level.                                   | Fill battery with distilled water to ¼ to ½ inch above top of plates.   |
|  | Step 2. Check for cracked battery case.  | Report to organizational maintenance.   |
| <b>TRANSMISSION</b>  |  |   |
| 1. MACHINE WILL NOT MOVE IN EITHER DIRECTION.                | Step 1. Check parking brake for complete disengagement.                            | Release brake.  |
|  | Step 2. Check control linkage for proper adjustment.                               | Report to organizational maintenance.   |
|  | Step 3. Check transmission fluid level.  | Add fluid as required to bring level to FULL mark on dipstick.  |
| 2. MACHINE MOVES SLOWLY IN BOTH DIRECTIONS AT FULL THROTTLE. | Step 1. Check transmission fluid level.  | Add fluid if necessary.   |
| 3. TRANSMISSION OVERHEATING.                                 | Step 1. Check transmission fluid level.  | Add fluid if necessary.   |

## CHAPTER 4

## ORGANIZATIONAL MAINTENANCE INSTRUCTION'

## Section I. SERVICE UPON RECEIPT OF MATERIEL

**4-1. Inspecting and Servicing the Equipment**

a. Conduct a complete visual inspection of the fork lift truck. Check to insure that all items are on the machine, and that no obvious damage occurred in shipment. Check for damage to lift and tilt cylinder rods such as nicks or deep scratches. Make sure that there is no paint on any of these cylinder rods.

b. Check to see that engine oil and transmission fluid register to the FULL mark on the dipsticks.

c. Check radiator coolant to insure that it is at correct level.

d. Remove battery cell covers and check to see that electrolyte is above top of plates.

e. Check to see that all lights (headlight, taillight, instrument lights, etc.) operate properly.

f. Check hydraulic reservoir to see that it is full.

g. Refer to LO 10-3930-632-12 and follow instructions therein if it becomes necessary to add fluids or lubricants.

## Section II. MOVEMENT TO A NEW WORKSITE

**4-2. Dismantling for Movement**

a. For short-distance movement over hard surfaces, no dismantling is necessary to move the fork lift truck. The truck is self-propelled and can be driven directly to the worksite.

b. If the new worksite is too far removed to conveniently drive the fork lift truck to the new location, or if the worksites are separated by other than smooth, hard-surfaced roads, the truck can be moved on a flatbed truck. No dismantling is normally necessary. If

space limitations require, the overhead guard (fig. 1-1) and the forks can be removed from the fork lift truck. Lift the load backrest from the carriage assembly. Lift the fork stop pin lever and slide the forks sideways from the carriage assembly.

**4-3. Reinstallation After Movement**

If it was necessary to remove the forks and load backrest, reinstall them on the carriage assembly.

## Section III. REPAIR PARTS, SPECIAL TOOLS, AND EQUIPMENT

**4-4. Tools and Equipment**

a. No basic issue tools or repair parts are issued with or authorized for use on the fork lift truck.

**4-5. Special Tools and Equipment**

a. No special tools or equipment are required to perform the operator's and organizational maintenance

on this fork lift truck.

**4-6. Maintenance Repair Parts**

a. Organizational maintenance repair parts for the fork lift truck are listed and illustrated in TM 10-3930-632-20P.

## Section IV. LUBRICATION INSTRUCTIONS

**4-7. General**

a. This section contains lubrication instructions which are supplemental to, and not specifically covered in the Lubrication Order LO 10-3930-632-12.

b. Use only the lubricants specified in the lubrication order. Carefully follow instructions given on the lubrication order to assure proper operation of the equipment.

**4-8. Detailed Lubrication Information**

a. *General.* Keep all lubricants in closed containers and store in a clean, dry place away from external heat. Allow no dust, dirt, or other foreign material to mix with the lubricants. Keep all lubrication equipment clean and ready for use.

b. *Cleaning.* Keep all external parts not requiring lubrication clean of lubricants. Before lubricating the equipment, wipe all lubrication points free of dirt and grease. Clean all lubrication points after lubrication to prevent accumulation of foreign matter.

c. *Points of Lubrication.* Service the lubrication points at proper intervals as illustrated in the lubrication order.

*d. Engine Oil Service.*

(1) To check the engine oil level, unlatch and swing out the right engine side panel and swing out the battery tray. Use the dipstick (fig. 3-1) to check the engine oil level. To add oil, remove the engine oil filler cap and pour oil as required into the filler opening. Check oil level frequently, since oil consumption may increase.

(2) The oil may require changing more frequently than usual because of contamination by dilution and increased sludge formation under cold weather operation conditions.

(3) Change the engine oil filter element (fig. 4-47) to coincide with engine oil changes. This is a spin-off filter. Turn counterclockwise to remove it from the filter base. Install the new filter and gasket, tightening hand tight only.

*e. Transmission Service.*

(1) The transmission fluid level is

measured on a dipstick (fig. 3-3) that is installed on the filler cap on the top front of the axle housing.

(2) To check the transmission fluid level, put the direction shift lever in neutral and start the engine. Run the engine for approximately four minutes. Stop the engine and remove the filler cap and dipstick (fig. 3-3) from the top front of the axle housing. Check the fluid level on the dipstick. If necessary, fill to the FULL mark on the dipstick, using the transmission fluid specified in the lubrication order.

(3) Install the filler cap and dipstick. Recheck fluid level.

(4) To change the transmission fluid, run the truck to warm the fluid to operating temperature. Drain the fluid by removing the transmission drain plug and differential drain plug at the bottom of the truck.

**CAUTION**

Do not use flushing compound to flush the transmission.

(5) Change the transmission oil filter element to coincide with transmission fluid change. When the transmission fluid is drained, remove the transmission oil filter element (fig. 4-60) and install a new element and gasket, tightening hand tight only.

(6) Reinstall the drain plugs and refill the transmission through the filler hole at the top front of the differential housing. Fill until the level is to the FULL mark on the dipstick of the filler cap and dipstick (fig. 3-3). Run the engine at fast idle with the direction shift lever in neutral. Recheck the transmission fluid level and add to bring level to the FULL mark.

**Section V. ORGANIZATIONAL PREVENTIVE MAINTENANCE CHECKS AND SERVICES****4-9. General.**

Preventive maintenance is detecting/correcting problems before they happen, or fixing little problems before they become big problems. Table 4-1 contains a list of preventive maintenance checks and services to be performed by organizational maintenance personnel. Attention to these checks and services will increase the useful life of the fork lift truck, but every possible problem cannot be covered in the PMCS, so you need to be alert for anything that might cause a problem. If anything does look wrong, and you can't fix it, write it on a DA Form 2404 and report it to your supervisor. Be sure to record any corrective action.

**4-10. Organizational Preventive Maintenance Checks and Services**

a. Perform the checks and services at the intervals shown in the table 4-1.

(1) Do the (Q) checks and services once each three months.

(2) Do the (S) checks and services twice a year, or each six months.

(3) Do the (A) checks and services once each year.

(4) Do the (B) checks and services once each two years.

(5) Do the (H) checks and services at the hour interval listed.

(6) Do the (MI) checks and services when the mileage of the vehicle reaches the amount listed.

b. If the fork lift truck doesn't work properly and you can't see what is wrong, refer to table 4-2 for troubleshooting instructions.

**WARNING**

Drycleaning solvent SD-2, used to clean parts, is potentially dangerous to personnel and property. Do not use near open flame or excessive heat. Flash point of solvent is 138°F.

c. Make cleanup a part of your preventive maintenance. Dirt, grease, oil, and debris may cover up a serious problem. Use drycleaning solvent (SD-2) to clean metal surfaces. Wipe off excess grease and spilled oil. Use soap and water when you clean rubber or plastic material.

d. Watch for and correct anything that might cause a problem with the equipment. Some things you should watch for are:

- (1) Bolts, nuts, and screws that are loose, missing, bent, or broken.
- (2) Welds that are bad or broken.
- (3) Electric wires and connectors that are bare, broken, or loose.
- (4) Hoses and fluid lines that lead, or show signs of damage or wear.

e. You should know how fluid leaks affect the status of your equipment. Learn and be familiar with the following definitions of the types/classes of leakage.

Leadage definitions for PMCS are:

- CLASS I Seepage of fluid (indicated by wetness or discoloration) not great enough to form drops.
- CLASS II Leakage of fluid great enough to form drops but not enough to cause drops to drip from the item being checked/inspected
- CLASS III Leakage of fluid great enough to form drops that fall from the item being checked/inspected.

**CAUTION**

Equipment operation is allowable with minor leakage (Class I or II). Of course, consideration must be given to the fluid capacity in the item/system being checked/inspected. When in doubt, notify your supervisor.

When operating with Class I or II leaks, continue to check fluid levels as required by the PMCS.

Class III leaks should be corrected before releasing equipment for operation.

Table 4-1. Organizational Preventive Maintenance Checks and Services

| ITEM NO. | INTERVAL    |                |            |              |         |         | ITEM TO BE INSPECTED<br>PROCEDURE: Check for and repair, fill or adjust as needed.   |
|----------|-------------|----------------|------------|--------------|---------|---------|--|
|          | Q-Quarterly | S-Semiannually | A-Annually | B-Biennially | H-Hours | M-Miles |  |
|          |             |                |            |              |         |         | NOTE<br>Perform Operator/Crew PMCS prior to or in conjunction with Organizational PMCS if:<br>a. There is a delay between the daily operation of the equipment and the Organization PMCS.<br>b. Regular operator is not assisting/participating. |
| 1        |             |                |            |              | 250     |         | <b>ENGINE OIL</b><br>Drain oil and replace engine oil filter. Refill with enough oil to bring oil level up to FULL mark on dipstick (ref. LO 10-3930-632-12).  |
| 2        |             |                |            |              | 250     |         | <b>FUEL FILTER</b><br>Clean bowl and element.  |
| 3        |             |                |            |              | 250     |         | <b>ENGINE TUNE-UP</b><br>a. Adjust or replace ignition points (point gap should be .022 inch).<br>b. Check spark plugs and replace as necessary (gap should be .030 inch).<br>c. Clean PCV valve.  |
| 4        |             |                |            |              | 250     |         | d. Check timing of engine.<br><b>VEE BELTS</b><br>Check belts for proper tension. Should be 1/2 to 3/4 inch deflection at point midway between pulleys under approximately 25 pounds of force.   |
| 5        |             |                |            |              | 250     |         | <b>BATTERY</b><br>Check specific gravity and charge as necessary. Clean terminals and insure all connections are tight. Inspect battery for corrosion. (Ref. TM 9-6140-200-14.)  |
| 6        |             |                |            |              | 250     |         | <b>BRAKE AND INCHING MASTER CYLINDERS</b><br>Check level of fluid. Fluid should be within 1/4 inch of top of reservoir.  |
| 7        |             |                |            |              | 250     |         | <b>STEERING DRAG LINK AND TIE ROD</b><br>Lubricate/check steering mechanism to insure it operates freely without binding.  |

Table 4-1. Organizational Preventive Maintenance Checks and Services - Continued

| ITEM NO. | INTERVAL    |                |            |              |                    |         | ITEM TO BE INSPECTED<br>PROCEDURE: Check for and repair, fill or adjust as needed.   |
|----------|-------------|----------------|------------|--------------|--------------------|---------|--|
|          | Q-Quarterly | S-Semiannually | A-Annually | B-Biennially | H-Hours            | M-Miles |  |
| 8        |             |                |            |              | 250                |         | <i>MASTASSEMBLY</i><br>a. Lubricate sliding and roller contact surfaces.   |
| 9        |             |                |            |              | 250<br>500         |         | b. Visually inspect chains for signs of wear, damage, or excess stress.<br><i>HYDRAULIC OIL TANK BREATHER</i><br>Clean breather. Replace if damaged or unserviceable.  |
| 10       |             |                |            |              | 500                |         | <i>BRAKE PEDAL ADJUSTMENT</i><br>Adjust brake pedal free play to from 118 to 114 inches.   |
| 11       |             |                |            |              | 500                |         | <i>PARKING BRAKE</i><br>Adjust as necessary to hold truck on approximately 15° slope. Lubricate linkage.   |
| 12       |             |                |            |              | 500                |         | <i>ELECTRICAL SYSTEM</i><br>Check tightness of terminals, wires, cables, and electrical components. Check for and have any broken wires replaced.  |
| 13       |             |                |            |              | 500                |         | <i>HOSES, TUBES AND FITTINGS</i><br>Inspect, replace or have replaced if necessary. Correct any leaks that are evident.  |
| 14       |             |                |            |              | 500<br>500<br>1000 |         | <i>WHEELS</i><br>a. Inspect brake shoes and replace as necessary (linings less than 1/16 inch).<br>b. Inspect wheel cylinders for leaks, cracks, or damage.<br>c. Clean and lubricate wheel bearings (ref. LO 10-3930-632-12). |
| 15       |             |                |            |              | 1000               |         | <i>TRANSMISSION AND DIFFERENTIAL</i><br>Drain oil and replace transmission oil filter. Refill with oil to bring fluid level up to FULL mark on dipstick (ref. LO 10-3930-632-12).  |
| 16       |             |                |            |              | 1000               |         | <i>HYDRAULIC RESERVOIR</i><br>Drain hydraulic oil and replace filter. Refill reservoir to bring level up to FULL mark on dipstick (ref. LO 10-3930-632-12).  |
| 17       |             |                |            |              | 1000               |         | <i>ENGINE VALVES</i><br>Check valve clearance and adjust as necessary.   |
| 18       |             |                |            |              |                    |         | <i>RADIATOR</i><br>Check antifreeze protection. Drain, flush and refill as required (ref. TB 750-651).   |

**Section VI. TROUBLESHOOTING**

**4-11. General**

a. This section contains troubleshooting information for locating and correcting most of the troubles which may develop in the fork lift truck. Each malfunction for an individual component, unit, or system is followed by a list of tests or inspections which will help to determine probable causes and corrective actions to

take. Perform the tests/inspections and corrective actions in the order listed.

b. This manual cannot list all malfunctions that may occur, nor all tests or inspections and corrective actions. If a malfunction is not listed or is not corrected by listed corrective actions, notify your supervisor. (See table 4-2).

Table 4-2. Troubleshooting

| MALFUNCTION  | TEST OR INSPECTION   | CORRECTIVE ACTION                                     |
|--|--|---|
| ENGINE   |  |   |
| 1. ENGINE WILL NOT START (AMMETER SHOWS NO DISCHARGE). |  |   |
|  | Step 1. Check for defective ignition switch.   | Replace switch if defective. Refer to paragraph 4-22. |
|  | Step 2. Inspect ignition primary wires and starting motor cables for breaks and loose connections. | Repair or replace and tighten.                        |
|  | Step 3. Check coil for open primary winding.   | Replace coil (para 4-36).                             |
|  | Step 4. Inspect distributor points for dirt and maladjustment.                                     | Clean, adjust or replace points (para 4-34).          |

Table 4-2. Troubleshooting-Continued

| MALFUNCTION  | TEST OR INSPECTION   | CORRECTIVE ACTION  |
|--|--|--|
| ENGINE-Continued   |  |  |
| 2. ENGINE WILL NOT START (AMMETER SHOWS ABNORMAL DISCHARGE). | Step 1. Check for defective capacitor  | Replace capacitor (para 4-34).   |
|  | Step 2. Inspect distributor cap and rotor for short circuited or burned condition.     | Replace defective parts (para 4-34).   |
|  | Step 3. Check for short circuit in wire between ammeter and ignition switch.           | Replace defective wire.  |
|  | Step 4. Check ignition coil for short-circuited primary winding.                       | Replace coil (para 4-36).  |
| 3. ENGINE WILL NOT START (WEAK SPARK OR NO SPARK).           | Step 1. Check to insure that distributor points are opening.                           | Clean or replace and adjust points (para 4-34).                                      |
|  | Step 2. Check for pitted or burned points.   | File or replace points (para 4-34).  |
|  | Step 3. Check for weak capacitor.  | Replace capacitor (para 4-34).   |
|  | Step 4. Check for weak coil.   | Replace coil (para 4-36).  |
|  | Step 5. Check spark plug gap.  | Reset plug gap (para 4-35).  |
| 4. ENGINE WILL NOT START (GOOD SPARK).                       | Step 1. Check carburetor for dirt, water or stuck float.                               | Replace or adjust carburetor (para 4-42).  |
|  | Step 2. Check to insure that fuel is reaching carburetor.                              | Repair or replace lines between tank and fuel pump, and between pump and carburetor. |
|  | Step 3. Inspect to insure that spark wires are correctly installed in distributor cap. | Install wires correctly.   |
|  | Step 4. Test engine timing.  | Reset timing (para 4-64).  |
|  | Step 5. Check fuel filter for clogged condition.                                       | Replace fuel filter (para 4-44).   |
|  | Step 6. Test fuel pump for proper output.  | Replace inoperative pump (para 4-43).  |
| 5. ENGINE BACKFIRES.   | Step 1. Test ignition timing.  | Reset timing (para 4-64).  |
|  | Step 2. Check to see that plug wires are correctly installed in distributor cap.       | Install wires correctly.   |
|  | Step 3. Inspect distributor cap for cracks and shorts.                                 | Replace defective distributor cap.   |
| 6. ENGINE OPERATES ERRATICALLY.                              | Step 1. Check ignition timing.   | Reset timing (para 4-64).  |
|  | Step 2. Check to see that spark plug wires are correctly installed.                    | Install wires correctly.   |
|  | Step 3. Inspect carburetor for dirt or water.  | Remove and clean carburetor. Clean fuel system.                                      |
|  | Step 4. Check carburetor for proper adjustment   | Adjust carburetor (para 4-42).   |
|  | Step 5. Inspect cylinder head for excessive carbon buildup.                            | Remove carbon from cylinder head.  |
|  | Step 6. Test fuel pump for sufficient pressure.  | Repair or replace pump (para 4-43).  |
|  | Step 7. Check for clogged fuel filter.   | Replace filter.  |
|  | Step 8. Inspect fuel lines for partially clogged or pinched condition.                 | Clean and repair fuel lines.   |
|  | Step 9. Check for intake manifold leak.  | Inspect gaskets and tighten mounting nuts.   |
|  | Step 10. Inspect for cracked or shorted distributor cap.                               | Replace distributor cap.   |

Table 4-2. Troubleshooting-Continued

| MALFUNCTION                                  | TEST OR INSPECTION  | CORRECTIVE ACTION |
|--|---|-------------------|
| ENGINE-Continued                             |   |                   |
| 7. ENGINE STALLS ON IDLE.                    | Step 1. Check carburetor throttle valve and idle mixture adjustment.<br>Adjust carburetor (para 4-42).  |                   |
|  | Step 2. Check carburetor for dirt or water in idler passages.<br>Replace carburetor.                    |                   |
|  | Step 3. Inspect intake manifold for leaks.<br>Replace manifold gaskets or tighten mounting nuts.        |                   |
|  | Step 4. Check spark plugs for incorrect gap or defective condition.<br>Clean or replace plugs. Set gap. |                   |
|  | Step 5. Check ignition timing.<br>Reset timing (para 4-64).   |                   |
|  | Step 6. Test engine compression.<br>Report to general support maintenance personnel.                    |                   |
|  | Step 7. Check for water leaks in cylinder head and head gasket.<br>Replace cylinder head (para 4-65).   |                   |
| 8. ENGINE MISFIRES ON ONE OR MORE CYLINDERS. | Step 1. Inspect spark plugs for dirty or cracked condition.<br>Clean, adjust, or replace plugs.         |                   |
|  | Step 2. Check for grounded spark plug wires.<br>Replace plug wires.                                     |                   |

Change 1 4-6



Table 4-2. Troubleshooting-Continued

| MALFUNCTION   | TEST OR INSPECTION   | CORRECTIVE ACTION   |
|---|--|---|
| ENGINE-Continued                                      |  |   |
| 8. ENGINE MISFIRES ON ONE OR MORE CYLINDERS-Continued | Step 3. Inspect plug wires for incorrect installation.   | Install plug wires correctly.                                       |
|   | Step 4. Inspect distributor cap and rotor for burned or broken condition.                              | Replace distributor cap or rotor.                                   |
|   | Step 5. Check engine compression.  | Report to general support maintenance personnel.                    |
|   | Step 6. Check for leaking cylinder head gasket.  | Replace gasket.   |
| 9. ENGINE DOES NOT IDLE PROPERLY.                     | Step 1. Check spark plugs for dirty condition or improper gap.   | Clean plugs and reset gap.  |
|   | Step 2. Check ignition timing.   | Reset timing (para 4-64).   |
| 10. ENGINE MISSES AT HIGH SPEEDS.                     | Step 1. Spark plugs for dirty or defective condition and improper gap.                                 | Clean, replace or reset plug gap.                                   |
|   | Step 2. Check ignition coil and condenser for weak condition.  | Replace coil and condenser.   |
|   | Step 3. Check for sticking, dirty or improperly adjusted ignition points.                              | Clean, adjust or replace points (para 4-34).                        |
|   | Step 4. Inspect distributor cap and rotor for cracks or burned condition.                              | Replace defective parts.  |
|   | Step 5. Check for leaking cylinder head gasket.  | Replace gasket or torque stud nuts (para 4-65).                     |
|   | Step 6. Check engine compression.  | Report uneven compression to general support maintenance personnel. |
|   | Step 7. Inspect plug wires for cracked insulation.   | Replace defective wires.  |
|   | Step 8. Check choke adjustment.  | Adjust choke (para 4-42).   |
|   | Step 9. Inspect carburetor accelerator pump. Check for dirt in metering jets or incorrect float level. | Replace carburetor.   |
|   | Step 10. Test fuel pump for sufficient fuel supply.  | Replace fuel pump.  |
|   | Step 11. Check air cleaner for dirty condition.  | Clean or replace air cleaner element.                               |
|   | Step 12. Check for clogged fuel filter.  | Clean or replace filter (para 4-44).                                |
|   | Step 13. Check for weak distributor breaker arm spring.  | Replace point set (para 4-4).                                       |
|   | Step 14. Check for excessive play in distributor shaft.  | Replace distributor (para 4-34).                                    |
| 11. ENGINE PINGS.                                     | Step 1. Check ignition timing.   | Reset timing (para 4-64).   |
|   | Step 2. Check distributor for automatic spark advance stuck in advance position, or broken spring.     | Replace distributor (para 4-34).                                    |
|   | Step 3. Check to insure that correct fuel is being used.   | Drain fuel system, fill with proper fuel.                           |
| 12. ENGINE LACKS POWER.                               | Step 1. Check ignition timing.   | Reset timing (para 4-64).   |
|   | Step 2. Check to insure that correct fuel is being used.   | Drain fuel system, fill with proper fuel.                           |
|   | Step 3. Check for leaking cylinder head gasket.  | Replace gasket.   |
|   | Step 4. Test engine running temperature-engine running cold.   | Replace thermostat (para 4-54).                                     |
|   | Step 5. Check oil and grade of oil being used.   | Replace with oil as outlined in lubrication order.                  |

Table 4-2. Troubleshooting-Continued

| MALFUNCTION                      | TEST OR INSPECTION   | CORRECTIVE ACTION   |
|----------------------------------|--|---|
| <b>ENGINE-Continued</b>          |  |   |
| 12. ENGINE LACKS POWER-Continued | Step 6. Check air cleaner element.   | Clean or replace element.   |
|                                  | Step 7. Check spark plug gaps.   | Reset plug gaps.  |
|                                  | Step 8. Check to insure that choke and throttle open fully.                                | Adjust choke, accelerator pedal and governor linkage (para 4-50).                               |
|                                  | Step 9. Inspect exhaust system for obstructions.   | Remove obstructions or replace parts.   |
|                                  | Step 10. Check engine compression.   | Report condition to general support maintenance personnel.                                      |
|                                  | Step 11. Check valve adjustment.   | Adjust valves (para 4-66).  |
|                                  | Step 12. Check to insure that sufficient fuel is being supplied.                           | Clean filter, inspect fuel pump, inspect carburetor for water or dirt and replace as necessary. |
| 13. HIGH ENGINE OIL CONSUMPTION. | Step 1. Check engine speeds with tachometer.   | Adjust governor as required.  |
|                                  | Step 2. Check for oil leaks.   | Report condition to general support maintenance personnel.                                      |
|                                  | Step 3. Check for diluted or improper oil.   | Drain and fill with proper grade of oil.  |
|                                  | Step 4. Check engine temperatures causing thinning of oil.                                 | Refer to ENGINE OVERHEATS, Item 21, below.  |
| 14. LOW ENGINE OIL PRESSURE.     | Step 1. Check oil level.   | Fill crankcase to full mark to dipstick.  |
|                                  | Step 2. Check for improper grade of oil and observe for foaming oil at high engine speeds. | Change oil, inspect crankcase vent tube and check for water in oil.                             |
|                                  | Step 3. Check for oil leaks.   | Report condition to general support maintenance personnel.                                      |
| 15. HIGH FUEL CONSUMPTION.       | Step 1. Check carburetor adjustment.   | Adjust carburetor as necessary (para 4-42).   |
|                                  | Step 2. Check engine speeds.   | Adjust carburetor (para 4-42).  |
|                                  | Step 3. Check condition of air cleaner element.  | Clean or replace air cleaner element.   |
|                                  | Step 4. Check carburetor float level. Test accelerator pump adjustment.                    | Replace carburetor.   |
|                                  | Step 5. Check for fuel line leaks.   | Replace lines. Correct leaks.   |
|                                  | Step 6. Check engine for overheated condition.   | Refer to ENGINE OVERHEATS, Item 21, below.  |
|                                  | Step 7. Inspect carburetor for worn and broken parts.                                      | Replace carburetor (para 4-42).   |
|                                  | Step 8. Test fuel pump for high pressure and check for leaking diaphragm.                  | Replace fuel pump (para 4-43).  |
|                                  | Step 9. Check ignition timing.   | Reset timing.   |
|                                  | Step 10. Check filter bowl and gasket for leaks.   | Replace defective parts.  |
|                                  | Step 11. Check engine compression.   | Report condition to general support maintenance personnel.                                      |
|                                  | Step 12. Check to see that choke is fully opening.   | Adjust choke control (para 4-42).   |
|                                  | Step 13. Test engine idle speed.   | Adjust carburetor idle speed screw (para 4-42).   |
|                                  | Step 14. Check spark plug condition and gap.   | Clean and gap plugs.  |

Table 4-2. Troubleshooting-Continued

| MALFUNCTION                           | TEST OR INSPECTION  | CORRECTIVE ACTION  |
|---------------------------------------|---|--|
| ENGINE-Continued                      |   |  |
| 15. HIGH FUEL CONSUMPTION-Continued   | Step 15. Test for weak coil.  | Replace coil.  |
|                                       | Step 16. Check for clogged exhaust system; damaged pipes.                                   | Replace defective parts.                                   |
| 16. LOW FUEL PRESSURE.                | Step 1. Check for air leaks in fuel lines.  | Tighten connections.                                       |
|                                       | Step 2. Test fuel pump pressure. Inspect pump diaphragm and linkage.                        | Replace fuel pump.   |
|                                       | Step 3. Check for clogged fuel lines.   | Clean fuel lines.  |
| 17. ENGINE IDLES TOO FAST.            | Step 1. Check carburetor throttle stop adjustment.  | Adjust idle speed adjust screw.                            |
|                                       | Step 2. Accelerator linkage sticking.   | Free and lubricate linkage.                                |
|                                       | Step 3. Check tension of accelerator linkage return spring.                                 | Replace spring.  |
| 18. FUEL GAGE DOES NOT REGISTER.      | Step 1. Check wire connections between tank and gage.                                       | Tighten connections.                                       |
| 19. LOSS OF COOLANT.                  | Step 1. Check for loose hose connections.   | Tighten hose connections.                                  |
|                                       | Step 2. Inspect hoses for damage and deterioration.   | Replace hoses.   |
|                                       | Step 3. Check radiator for leaks.   | Replace radiator (para 4-53).                              |
| 20. ENGINE TOO COOL DURING OPERATION. | Step 1. Test thermostat for proper operation.   | Replace defective thermostat and gasket (para 4-54).       |
| 21. ENGINE OVERHEATS.                 | Step 1. Check for obstructions in radiator core.  | Clear obstructions.  |
|                                       | Step 2. Check engine coolant level.   | Fill radiator to proper level.                             |
|                                       | Step 3. Test thermostat for proper operation.   | Replace thermostat.  |
|                                       | Step 4. Check for leaking cylinder head gasket.   | Replace gasket.  |
|                                       | Step 5. Inspect coolant hoses and fan belt for wear and deterioration.                      | Replace unserviceable parts.                               |
|                                       | Step 6. Inspect radiator and water pump for leaks.  | Replace defective parts.                                   |
|                                       | Step 7. Check for loose fan belts.  | Adjust fan belts (para 4-55).                              |
|                                       | Step 8. Check ignition timing.  | Reset timing (para 4-64).                                  |
|                                       | Step 9. Inspect muffler and pipes for damage and clogging.                                  | Replace defective parts.                                   |
|                                       | Step 10. Check to insure that crankcase is full and that proper grade of oil is being used. | Fill crankcase with proper grade of oil.                   |
|                                       | Step 11. Check air cleaner element for restriction.   | Clean or replace element.                                  |
|                                       | Step 12. Check ignition timing.   | Reset timing (para 4-64).                                  |
|                                       | Step 13. Check engine compression.  | Report condition to general support maintenance personnel. |

Table 4-2. Troubleshooting-Continued

| MALFUNCTION                                      | TEST OR INSPECTION  | CORRECTIVE ACTION  |
|--|---|--|
| ELECTRICAL SYSTEM                                |   |  |
| 1. STARTING MOTOR CRANKS ENGINE SLOWLY.          | Step 1. Check grade of oil being used.<br>Change oil to proper grade.<br>Step 2. Test battery for weak condition.<br>Replace battery.<br>Step 3. Check for shorted battery cell.<br>Replace battery.  | Step 4. Inspect battery posts for loose connections and corrosion.<br>Clean and tighten terminals and cables.<br>Step 5. Test starter motor (para 4-33, c).<br>Replace starter motor (para 4-33, d). |
| 2. STARTING MOTOR DOES NOT CRANK ENGINE.         | Step 1. Check for too heavy engine oil.<br>Change to proper grade of oil.<br>Step 2. Check for defective solenoid, cables or starter motor; loose connections.<br>Replace defective starter motor (para 4-33) or cables. Tighten connections.<br>Step 3. Check for jammed condition of starter motor pinion and ring gear.<br>Free-up pinion or replace starter motor (para 4-33).<br>Step 4. Check starter relay.<br>Replace starter relay (fig. 4-50).<br>Step 5. Check for faulty ignition switch.<br>Replace defective switch (para 4-22).<br>Step 6. Check for faulty neutral starting switch.<br>Replace faulty switch. |  |
| 2.1. STARTING MOTOR ENGAGES WITH ENGINE RUNNING. | Step 1. Check ignition ballast resistor which is mounted on the firewall and connected to the green wire from terminal 4 of voltage regulator. Ohmmeter reading across resistor terminals should be 15 ohms $\pm$ 10%.<br>Replace defective resistor.<br>Step 2. Check starter relay circuit. With engine running, ohmmeter should read open between terminals 1 and 2.<br>Replace defective relay.   |  |
| 3. NO ALTERNATOR OUTPUT                          | Step 1. Test for defective voltage regulator.<br>Adjust or replace regulator.<br>Step 2. Test alternator (para 4-31).<br>Replace alternator.  |  |
| 4. LOW OR FLUCTUATING ALTERNATOR OUTPUT          | Step 1. Check for loose fan belt.<br>Adjust belt (para 4-55).<br>Step 2. Inspect for loose or dirty electrical connections.<br>Clean and tighten connections.<br>Step 3. Test for defective alternator.<br>Replace defective alternator (para 4-31).<br>Step 4. Test voltage regulator.<br>Adjust or replace voltage regulator (para 4-32).   |  |
| 5. EXCESSIVE ALTERNATOR OUTPUT.                  | Step 1. Test alternator (para 4-31).<br>Replace defective alternator.<br>Step 2. Test voltage regulator.<br>Adjust or replace voltage regulator (para 4-31).  |  |
| 6. EXCESSIVE ALTERNATOR NOISE.                   | Step 1. Check for loose pulley or mounting.<br>Tighten loose parts.<br>Step 2. Inspect for defective bearings or armature rubbing.<br>Replace alternator.   |  |
| 7. BATTERY DISCHARGED.                           | Step 1. Check electrolyte level.<br>Fill with distilled water to above battery plates.<br>Step 2. Inspect for short in battery cell.<br>Replace battery.<br>Step 2. Inspect battery connections for loose, dirty or corroded terminals.<br>Clean and tighten cables; replace parts as required.   |  |

*Table 4-2. Troubleshooting-Continued*

---

| <b>MALFUNCTION</b> | <b>TEST OR INSPECTION</b> | <b>CORRECTIVE ACTION</b> |
|--------------------|---------------------------|--------------------------|
|--------------------|---------------------------|--------------------------|

---

## ELECTRICAL SYSTEM-Continued

- Step 4. Test for short circuits.  
Repair or replace wires or parts as necessary.
8. LIGHTS DO NOT LIGHT
- Step 1. Check to insure that switch is fully ON.  
Turn switch fully ON.

**Change 1 4-10.1**

Table 4-2. Troubleshooting-Continued

| MALFUNCTION                        | TEST OR INSPECTION   | CORRECTIVE ACTION |
|------------------------------------|--|-------------------|
| <b>ELECTRICAL SYSTEM-Continued</b> |  |                   |
| 8. LIGHTS DO NOT LIGHT-Continued   | Step 2. Inspect for loose or dirty connections and broken wires.<br>Replace or clean parts. Tighten connections.   |                   |
|                                    | Step 3. Check for shorted or open circuit.<br>Repair or replace parts.   |                   |
|                                    | Step 4. Check for burned out bulb.<br>Replace bulb.  |                   |
|                                    | Step 5. Test for faulty switch.<br>Replace switch.   |                   |
| 9. LIGHTS DIM.                     | Step 1. Check for loose, dirty or corroded connections.<br>Clean and tighten connections.  |                   |
|                                    | Step 2. Test for short circuit in wiring.<br>Replace parts as required to correct short.   |                   |
|                                    | Step 3. Check for defective switch.<br>Replace switch.   |                   |
|                                    | Step 4. Test for weak battery.<br>Recharge or replace battery.   |                   |
| 10. HORN SOUNDS CONTINUOUSLY.      | Step 1. Check for short circuit in wiring between horn and horn button.<br>Locate and replace defective wire.  |                   |
| 11. HORN WILL NOT SOUND.           | Step 1. Check for blown horn fuse.<br>Replace fuse.  |                   |
|                                    | Step 2. Inspect connections for corrosion and security.<br>Clean and tighten connections.  |                   |
|                                    | Step 3. Check for open circuit.<br>Repair or replace wire.   |                   |
| <b>DRIVE AXLE</b>                  |  |                   |
| 1. CONTINUOUS DRIVE AXLE NOISE.    | Step 1. Inspect tires for severe and uneven wear.<br>Report condition to general support maintenance personnel.  |                   |
|                                    | Step 2. Check wheel bearings for proper adjustment.<br>Adjust wheel bearings (para 4.71).  |                   |
|                                    | Step 3. Check lubricant level in axle.<br>Fill axle to proper level. Refer to lubrication order.   |                   |
| <b>STEERING SYSTEM</b>             |  |                   |
| 1. DIFFICULT STEERING.             | Step 1. Check for bent or misaligned parts.<br>Replace defective drag link or tie rod (para 5-49). Report defective steering gear to direct support maintenance personnel. |                   |
| 2. TRUCK WANDERS OR WEAVES.        | Step 1. Inspect drag link for loose connections.<br>Adjust drag link (para 4-60)   |                   |
|                                    | Step 2. Check for loose wheel bearings.<br>Adjust wheel bearings (para 4-71).  |                   |
|                                    | Step 3. Check steering gear mounting bolts for security.<br>Tighten loose bolts.   |                   |
| 3. SHIMMY OR WOBBLE AT LOW SPEEDS. | Step 1. Inspect drag link for loose connections.<br>Adjust and tighten drag link (para 4-60).  |                   |
|                                    | Step 2. Check for loose wheel bearings.<br>Adjust wheel bearing (para 4-71).   |                   |
| 4. TRUCK PULLS TO ONE SIDE.        | Step 1. Check opposite side tires for uneven wear.<br>Report condition to general support maintenance personnel.   |                   |
|                                    | Step 2. Check for tight wheel bearings.<br>Adjust and lubricate wheel bearings (para 4-71).  |                   |
|                                    | Step 3. Inspect steering arm for damage or loose connection.<br>Report condition to direct support maintenance personnel.  |                   |

Table 4-2. Troubleshooting-Continued

| MALFUNCTION  | TEST OR INSPECTION  | CORRECTIVE ACTION  |
|--|---|--|
| <b>BRAKES</b>  |   |  |
| 1. BRAKES GRAB.  | Step 1. Inspect brake shoes for evidence of grease or oil on lining.<br>Step 2. Check linings for imbedded dirt and grit.<br>Step 3. Check for rough or scored drum.  | Replace brake shoes (para 4-75).<br>Clean linings with a stiff brush.<br>Replace drum and brake shoe assemblies (para 4-75).   |
| 2. BRAKES DRAG.  | Step 1. Check for improper pedal adjustment.<br>Step 2. Check to see if brake shoe anchor pin is tight in shoe.<br>Step 3. Inspect for broken or weak brake shoe return spring.<br>Step 4. Check for loose or damaged wheel bearings.   | Adjust brake pedal and linkage (para 4-78). Report defective parts to direct support maintenance personnel.<br>Free pin and lubricate lightly.<br>Report condition to direct support maintenance personnel.<br>Adjust or replace wheel bearings (para 4-71). |
| 3. BRAKE LOCKED.   | Step 1. Check for free travel in pedal and linkage.<br>Step 2. Inspect brake shoe assembly for jammed condition.  | Free binding linkage and pedal. Determine and correct cause; lubricate linkage. Report defective parts to direct support maintenance personnel for repair.<br>Report condition to direct support maintenance personnel.                                      |
| 4. BRAKE NOISE OR CHATTER.                               | Step 1. Inspect brake linings for wear.<br>Step 2. Inspect brake linings for grease.<br>Step 3. Inspect brake shoes for imbedded dirt.<br>Step 4. Check to insure that proper linings are being used and are securely mounted.<br>Step 5. Check brake shoes and drums for distortion. | Replace worn brake shoes (para 4-75).<br>Locate and correct leakage. Replace affected shoes and parts (para 4-75).<br>Clean linings with wire brush.<br>Install proper linings (para 4-75).<br>Replace defective parts.                                      |
| 5. EXCESSIVE BRAKE PEDAL TRAVEL.                         | Step 1. Inspect linings for wear.<br>Step 2. Check pedal free travel.   | Replace linings (para 4-75).<br>Adjust brake pedal and linkage (para 4-78).  |
| 6. EXCESSIVE PEDAL PRESSURE NECESSARY TO ACTUATE BRAKES. | Step 1. Check master cylinder fluid level.<br>Step 2. Check linings for oil saturation; glazed or worn linings.<br>Step 3. Check shoes and drums for warpage; scored drum.  | Add fluid as necessary.<br>Replace defective or worn linings (para 4-75).<br>Replace defective parts (para 4-75).  |
| <b>WHEELS</b>  |   |  |
| 1. WHEEL WOBBLE.   | Step 1. Check wheels for warpage or damage.<br>Step 2. Check wheels for security of mounting.<br>Step 3. Check wheel bearings for play.   | Replace defective parts.<br>Tighten wheel mounting studs.<br>Adjust wheel bearings (para 4-71).  |
| <b>HYDRAULIC SYSTEM</b>                                  |   |  |
| 1. HYDRAULIC PUMP NOT DELIVERING OIL.                    | Step 1. Check hydraulic tank level.<br>Step 2. Check for air leak in hydraulic lines.   | Fill tank with fluid as specified in lubrication order.<br>Replace parts as required to effect repair.   |

Table 4-2. Troubleshooting-Continued

| MALFUNCTION                                    | TEST OR INSPECTION  | CORRECTIVE ACTION |
|--|---|-------------------|
| HYDRAULIC SYSTEM-Continued                     |   |                   |
| 1. HYDRAULIC PUMP NOT DELIVERING OIL-Continued | Step 3. Check to insure that proper viscosity oil is being used.<br>Fill tank with oil as specified in lubrication order. |                   |
|  | Step 4. Check for clogged line or hydraulic filter.<br>Clear obstructions in lines. Replace filter (para 4-27).           |                   |
|  | Step 5. Check pump to insure proper operation.<br>Report defective pump to direct support maintenance personnel.          |                   |
| 2. FORKS DO NOT LIFT TO MAXIMUM HEIGHT.        | Step 1. Check hydraulic fluid level.<br>Fill hydraulic tank with fluid as specified in lubrication order.                 |                   |
| 3. LIFT OR TILT ACTION FAILS.                  | Step 1. Test hydraulic fluid pressure.<br>Refer to HYDRAULIC PUMP NOT DELIVERING OIL, Item 1.                             |                   |
|  | Step 2. Check for oil leak at top of lift cylinder.<br>Report leak to direct support maintenance personnel.               |                   |
|  | Step 3. Inspect tilt cylinder for leaks around piston rod.<br>Repair or replace tilt cylinder (para 4-25).                |                   |
| 4. LOAD IS NOT LIFTED EVENLY.                  | Step 1. Check to insure that load weight is centered over forks.<br>Center load weight over forks.                        |                   |
|  | Step 2. Check lift chain alignment.<br>Adjust lift chains (pare 4-26).  |                   |
| TRANSMISSION                                   |   |                   |
| 1. TRUCK WILL NOT MOVE IN EITHER DIRECTION.    | Step 1. Check to insure that parking brake is released.<br>Release parking brake.   |                   |
|  | Step 2. Check transmission oil level.<br>Fill transmission with oil as specified in lubrication order.                    |                   |
|  | Step 3. Check for proper linkage adjustment.<br>Adjust transmission shift linkage (para 4-83).                            |                   |
| 2. TRUCK WILL MOVE ONLY IN ONE DIRECTION.      | Step 1. Check transmission linkage for proper adjustment.<br>Adjust transmission shift linkage (para 4-83).               |                   |
| 3. TRUCK MOVES SLOWLY AT FULL THROTTLE.        | Step 1. Check transmission oil level.<br>Fill transmission with oil as specified in lubrication order.                    |                   |
|  | Step 2. Check for dragging brakes.<br>Refer to BRAKES DRAG, Item 2.   |                   |
| 4. TRANSMISSION OVERHEATING.                   | Step 1. Check transmission oil level.<br>Fill transmission with oil as specified in lubrication order.                    |                   |
|  | Step 2. Check for dragging brakes.<br>Refer to BRAKES DRAG, Item 2.   |                   |
|  | Step 3. Check for obstructed or plugged radiator.<br>Flush radiator. Clear obstructions (para 4-53).                      |                   |

**Section VII. RADIO INTERFERENCE SUPPRESSION**

**4-12. General Methods Used to Attain Proper Suppression**

Essentially, suppression is attained by providing a low resistance path to ground for stray currents. The methods used include shielding the ignition and high-frequency wires, grounding the frame with bonding straps, and using capacitors and resistors.

**4-13. Interference Suppression Components.**

a. *Primary Suppression Components.* The primary suppression components are those whose primary function is to suppress radio interference. These components are described and located in figure 4-1.



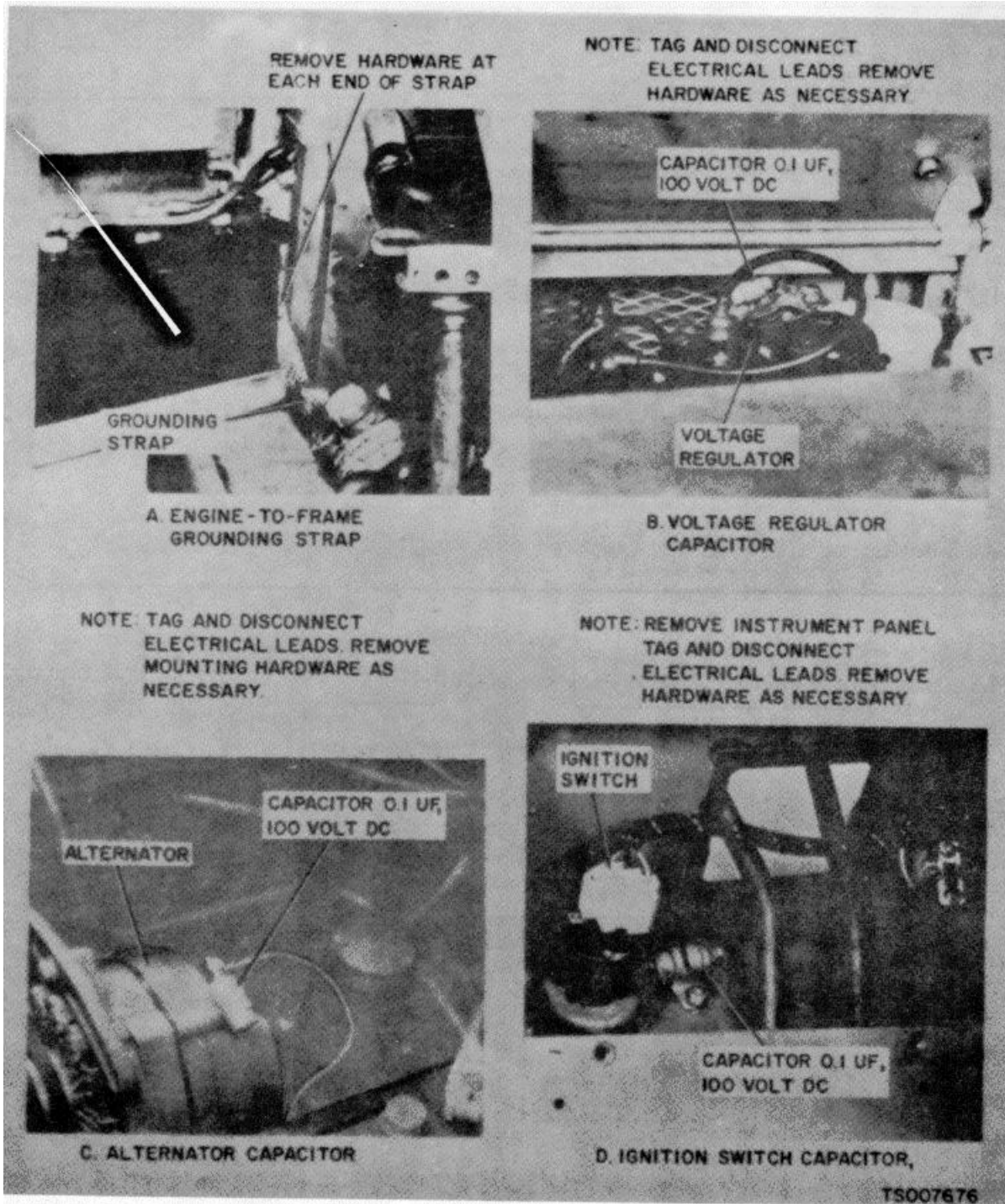

Figure 4-1. Interference Suppression Components, Removal and Installation, Sheet 1

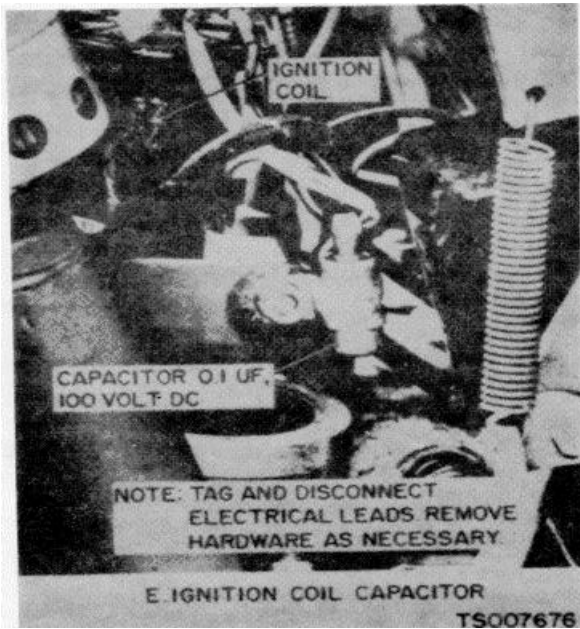

Figure 4-1. Interference Suppression Components, Removal and Installation, Sheet 2

*b. Secondary Suppression Components.* These components have radio interference suppression functions which are incidental or secondary to their primary functions.

**4-14. Replacement of Suppression Components**

Refer to figure 4-1 and replace the radio interference suppression components.

**4-15. Testing of Radio Interference Suppression Components**

Test the capacitors for leaks and shorts on a capacitor tester; replace defective capacitors. If test equipment is not available and interference is indicated, isolate the cause of interference by the trial-and-error method of replacing each capacitor in turn until the cause of interference is located and eliminated.

**Section VIII. OVERHEAD GUARD AND FLOOR PLATE**

**4-16. General**

An overhead guard is provided to protect the lift truck operator from falling objects. It is imperative that the guard be installed on the truck and in good condition at all times.

**4-17. Overhead Guard**

*a. Inspection.* Visually inspect the overhead

guard periodically to insure good condition and security of mounting hardware.

*b. Removal.* Remove the overhead guard as shown in figure 4-2. Remove the mounting hardware and lift the overhead guard off of the lift truck.

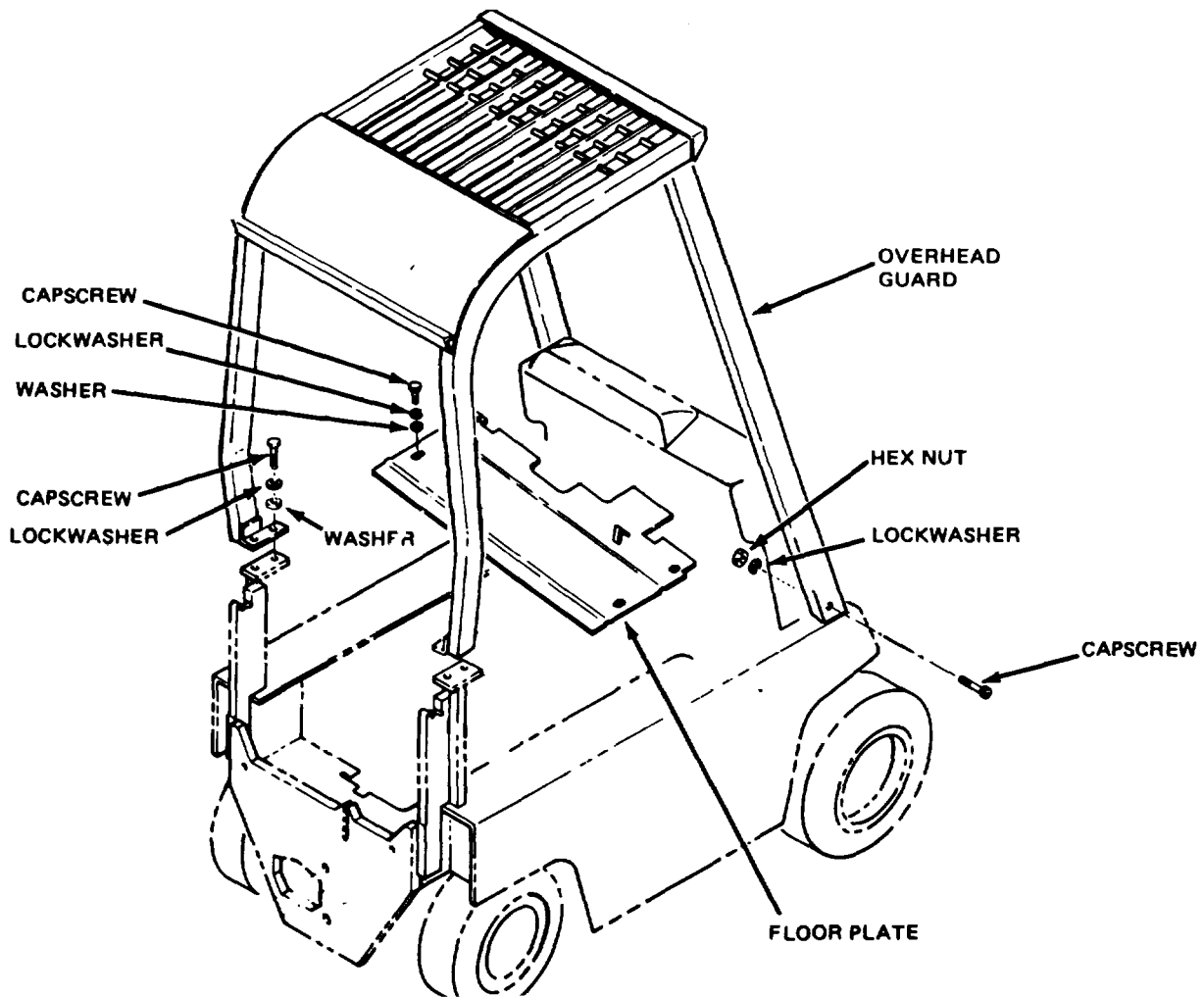

TS007677

Figure 4-2. Overhead Guard and Floor Plate, Removal and Installation

c. *Installation.* Lift new overhead guard into position on lift truck. Align mounting holes and install mounting hardware. Tighten hardware securely.

**4-18. Floor Plate**

a. *Inspection.* Periodically inspect floor plate for damage and security of mounting hardware.

b. *Removal.* Remove the accelerator pedal and necessary linkage to facilitate removal of floor plate. Loosen and remove mounting hardware as shown in figure 4-2. Lift floor plate out of lift truck.

**Section IX. OPERATOR'S SEAT**

**4-19. General**

A one man seat is provided for the lift truck operator. The seat has padded seat and back-rest panels and is forward-to-back adjustable.

**4-20. Operator's Seat**

a. *Adjustment.* The operator's seat may be adjusted to suit individual requirements. To adjust, release the latch mechanism on the right side of the

seat by pulling out on the lever. Slide the seat forward or back as required. Release the latch mechanism to lock the seat in position.

b. *Removal.* Remove the operator's seat by referring to figure 4-3, and removing nuts (8), lockwashers (9), cap screws (12) and washers (13). Lift entire seat assembly from engine cover.

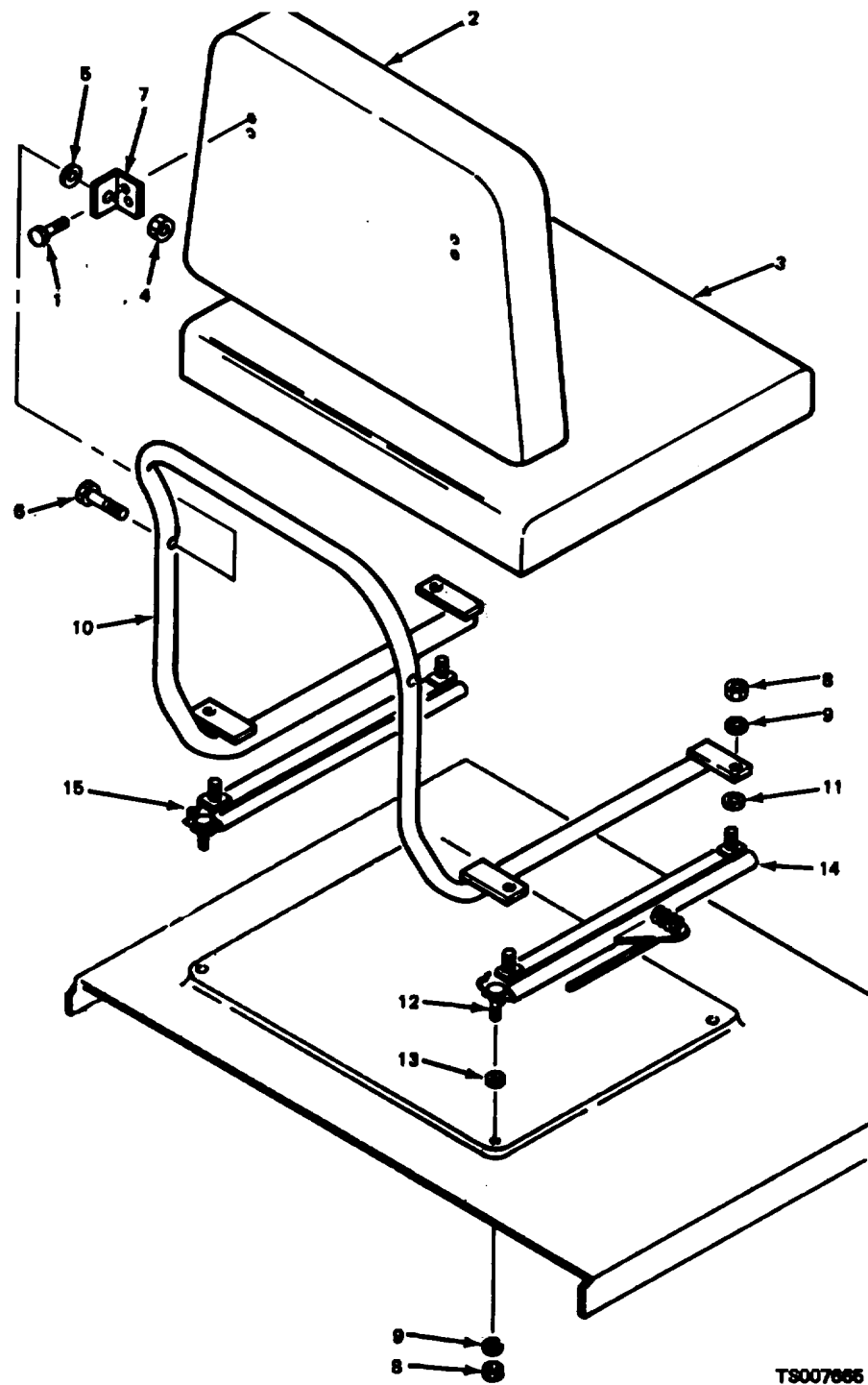

T9007665

- |                    |                         |
|--------------------|-------------------------|
| 1. Capscrew        | 9. Lockwasher           |
| 2. Seat back panel | 10. Frame               |
| 3. Seat panel      | 11. Washer              |
| 4. Nut             | 12. Capscrew            |
| 5. Washer          | 13. Washer              |
| 6. Capscrew        | 14. R. H. seat adjuster |
| 7. Seat bracket    | 15. L. H. seat adjuster |
| 8. Nut             |                         |

Figure 4-3. Operator's Seat

*c. Installation.* Place assembled seat on engine cover and align mounting holes. Lift seat slightly and

place a washer (13) in position. Install screws (12), lockwashers (9) and nuts (8). Tighten nuts securely.

## Section X. BODY PANELS AND HOODS

### 4-21. General

The body panels and hoods consist of sheet metal covers such as side and top engine covers, radiator cover, instrument panel and support, and front cowl.

*a. Inspection.* The body panels should be inspected periodically for signs of damage, chipped paint and rust.

*b. Removal.* Removal of the body panels may

be accomplished by referring to figure 4-4, and removing those items necessary for replacement or repair.

*c. Repair.* Repair of damaged body panels usually consists of replacement of the affected part. Chipped paint and light rust may, however, be repaired by sanding the finish to bare metal, applying primer and finish paint to restore panel to original condition.

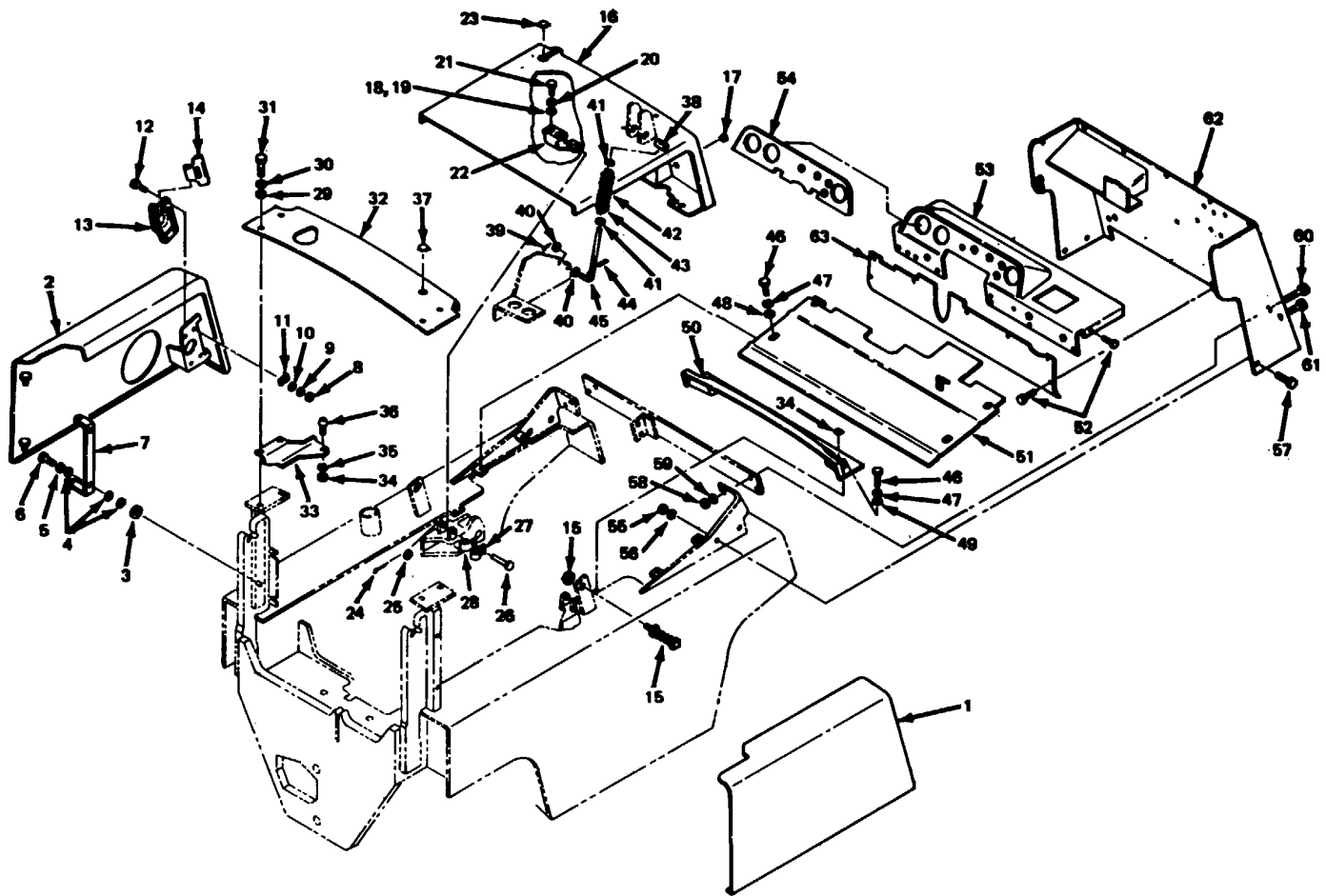

- |                    |                  |                |                |                 |                |
|--------------------|------------------|----------------|----------------|-----------------|----------------|
| 1. R. H. side hood | 12. Capscrew     | 23. Plug       | 33. Bracket    | 43. Spring      | 53. Cover      |
| 2. L. H. side hood | 13. Latch        | 24. Cotter pin | 34. Nut        | 44. Pin         | 64. Plate      |
| 3. Washer          | 14. Latch        | 25. Washer     | 35. Lockwasher | 45. Rod         | 55. Nut        |
| 4. Washer          | 15. Dovetail     | 26. Pin        | 36. Bumper     | 46. Capscrew    | 56. Lockwasher |
| 5. Lockwasher      | 16. Seat support | 27. Clip       | 37. Plug       | 47. Lockwasher  | 57. Capscrew   |
| 6. Capscrew        | 17. Plug         | 28. Clip       | 38. Pin        | 48. Washer      | 58. Nut        |
| 7. Bracket         | 18. Washer       | 29. Washer     | 39. Cotter pin | 49. Washer      | 59. Lockwasher |
| 8. Nut             | 19. Washer       | 30. Washer     | 40. Washer     | 50. Riser       | 60. Capscrew   |
| 9. Lockwasher      | 20. Washer       | 31. Capscrew   | 41. Washer     | 51. Floor panel | 61. Capscrew   |
| 10. Washer         | 21. Capscrew     | 32. Cover      | 42. Spring     | 52. Capscrew    | 62. Cowl       |
| 11. Clip           | 22. Bracket      |                |                |                 | 63. Panel      |

Figure 4-4. Body Panels and Hoods

Section XI. INSTRUMENT PANEL AND INSTRUMENTS

4-22. Instrument Panel

a. Removal and Disassembly.

**CAUTION**

Disconnect the positive battery cable from the battery before disconnecting electrical

leads from the controls and instruments on the instrument panel.

(1) Remove the assembled instrument panel from the lift truck as shown in figure 4-5.

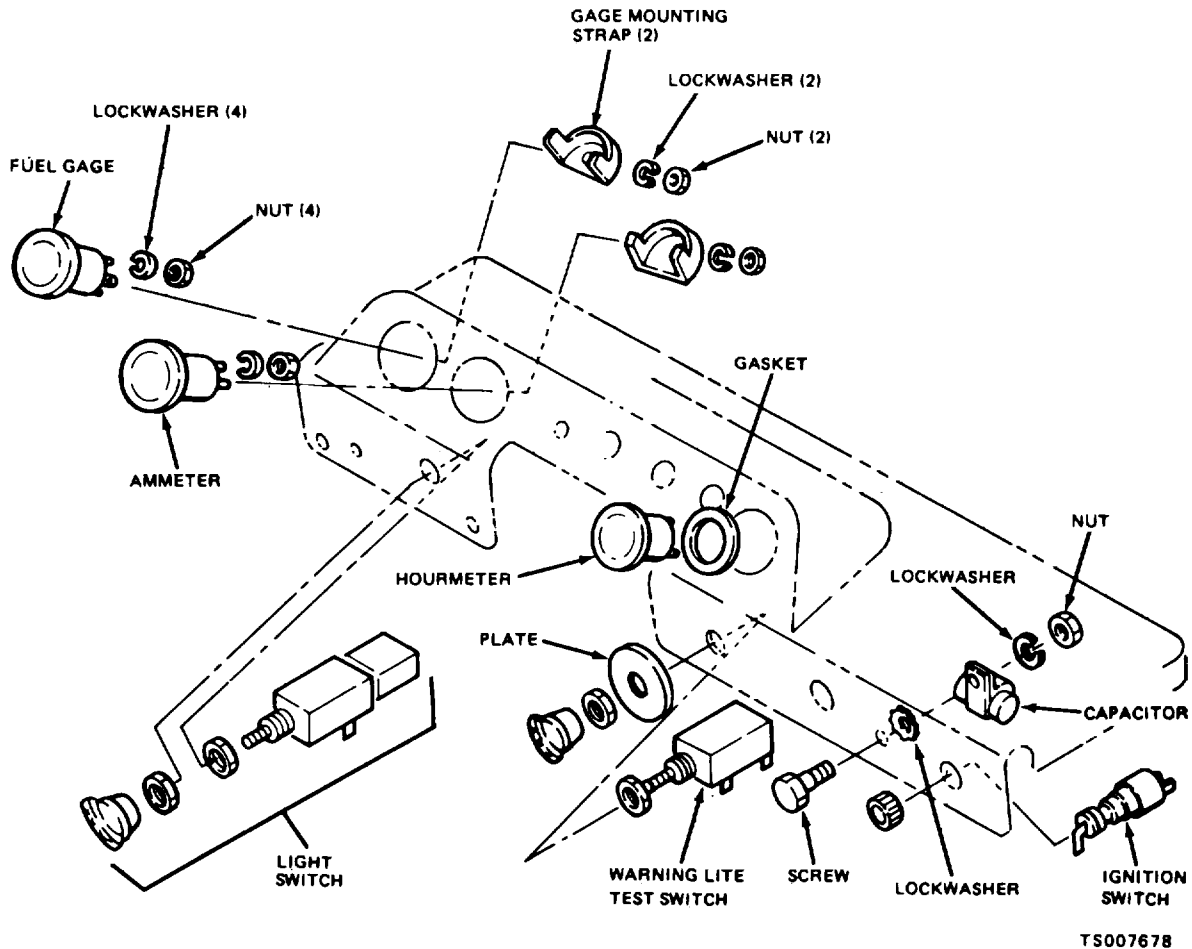

Figure 4-5. Instrument Panel, Disassembly and Reassembly

(2) Tag all leads before disconnecting them to assure that they are identified for reassembly.

(3) Disassemble the instrument panel as required, as shown in figure 4-5.

**WARNING**

Dry cleaning solvent, P-D-680, used to clean parts is potentially dangerous to personnel and property. Avoid repeated and prolonged skin contact. Do not use near open flame or excessive heat. Flash point of solvent is 100°F. -138°F. (38°C. -60°C.).

b. Cleaning and Inspection.

(1) Clean the meters, gages, and switches with a cloth dampened with dry cleaning solvent P-D-680. Take care to prevent solvent from entering the parts.

(2) Clean all other parts with dry cleaning solvent P-D-680; dry thoroughly.

(3) Inspect meters and gages for cracked glass, illegible dial faces, damaged terminals, faulty movements, and other damage.

(4) Inspect switches for rough, catching, or binding operation, damaged terminals, signs of

overheating, damaged threads, and other damage; replace damaged switches.

(5) Inspect the instrument panels for cracks, dents, distortion, and other damage; replace damaged instrument panels.

*c. Reassembly and Installation.*

(1) Reassemble the instrument panel as shown in figure 4-5.

(2) Connect the electrical leads following the instructions on the tags that were installed at

disassembly. If any tags were destroyed, refer to the wiring diagram (fig. 1-3) to determine the connection requirements.

(3) Install the instrument panel as shown in figure 4-5.

*d. Testing.* Proper operation and function of the gages can be tested by running the truck engine and observing all gages. Check the fuel gage, ammeter, oil gage, and temperature gage for proper readings.

**Section XII. HYDRAULIC LIFT COMPONENTS**

**4-23. General**

The hydraulic lift system consists of a hydraulic pump, oil reservoir, control valve, lift cylinder, tilt cylinders, and a tilt-lock valve, together with their connecting hoses and tubes. Hydraulic oil is drawn from the reservoir by the pump which is mounted on the engine front cover. The oil is forced through a high pressure line to the control valve. When the lift and tilt control levers are in neutral position, oil flows through the valve and back to the reservoir. When one of the control levers is depressed, oil is diverted through tubes and hoses to the corresponding cylinder and the desired motion is performed. When the limit of this motion or stroke is reached (piston rod fully extended or retracted), pressure built up in the system to approximately 2000 PSI forces a plunger in the relief valve section of the control valve to open and return excess oil to the reservoir. The tilt-lock valve prevents the flow of oil to and from the tilt cylinders when the hydraulic system is not pressurized even though the control valve lever is depressed. This prevents tilting of the mast when the engine is not running.

**4-24. Tilt-Lock Valve**

*a. Removal.* Remove the tilt-lock valve as shown in figure 4-6.

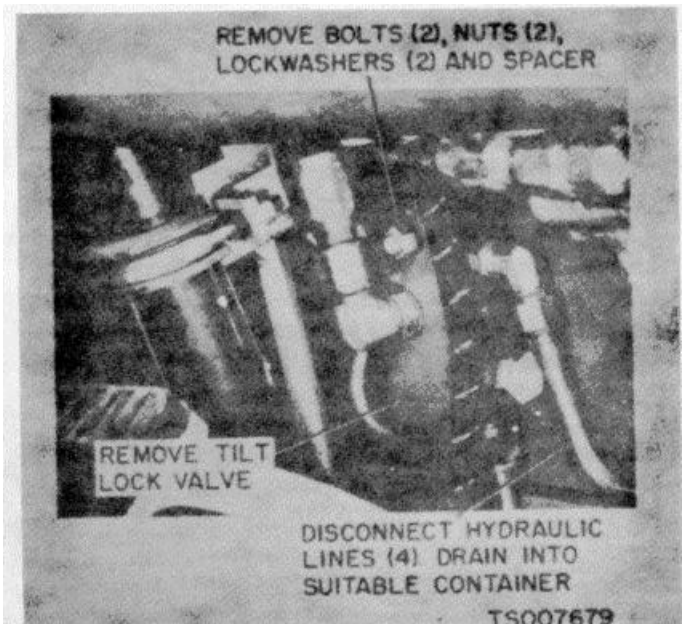

Figure 4-6. Tilt-Lock Valve, Removal and Installation



**WARNING**

Dry cleaning solvent, P-D-680, used to clean parts is potentially dangerous to personnel and property. Avoid repeated and prolonged skin contact. Do not use near open flame or excessive heat. Flash point of solvent is 100°F. -138°F. (38°C. - 60°C.).

*b. Cleaning and Inspection.*

- (1) Clean the tilt-lock valve with a cloth dampened with dry cleaning solvent P-D-680.
- (2) Inspect the valve body for cracks, signs of leaking, and other damage.
- (3) Inspect the inlet and outlet ports for obstructions and for damaged threads.
- (4) Replace a defective valve.

*c. Installation.* Install the tilt-lock valve as shown in figure 4-6.

**4-25. Tilt Cylinder**

*a. Removal.*

- (1) Lower the carriage to the floor. Secure the mast to the overhead guard to prevent the mast from tipping when hydraulic pressure is relieved.
- (2) Remove the floor plate.
- (3) Place a drain pan under the tilt cylinder. Disconnect the two hydraulic hoses from the tilt cylinder and allow the cylinder and hoses to drain.
- (4) Remove the tilt cylinder as shown in figure 4-7.

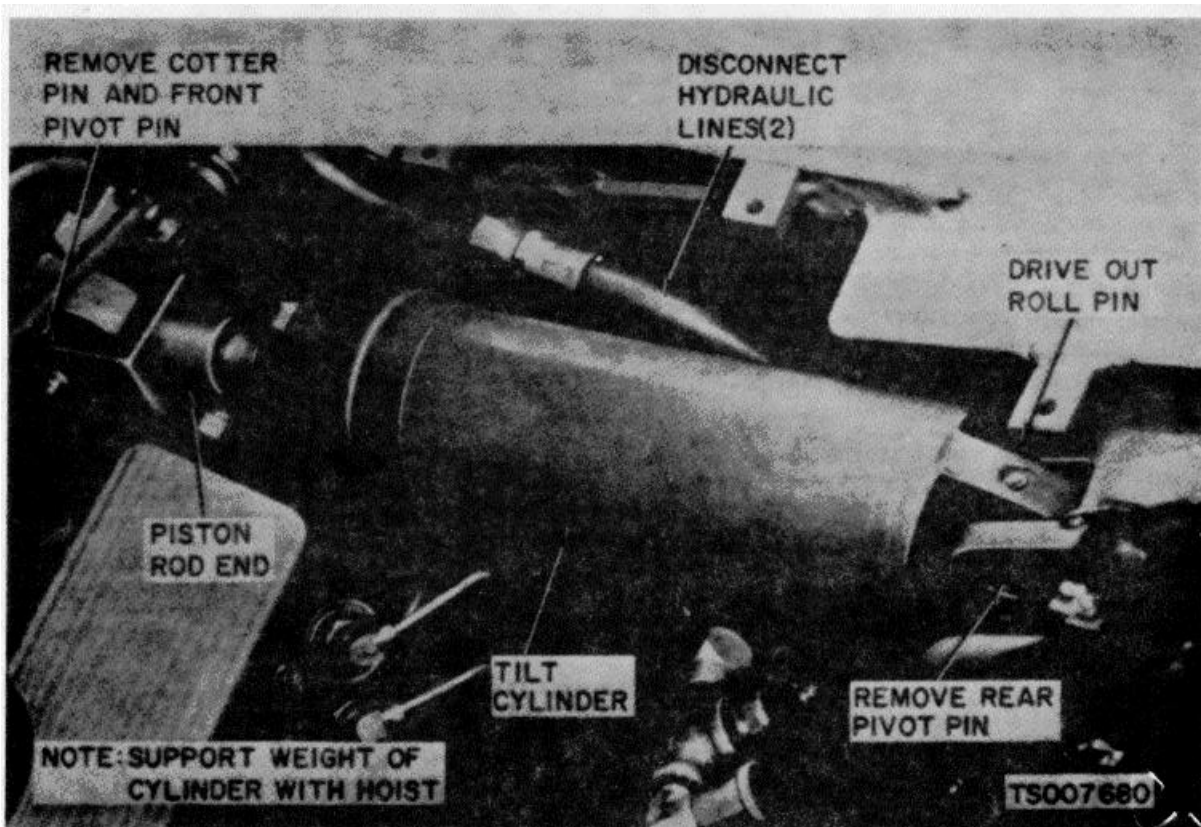

Figure 4-7. Tilt Cylinder, Removal and Installation

*b. Disassembly.*

- (1) Disassemble the tilt cylinder as shown in figure 4-8.

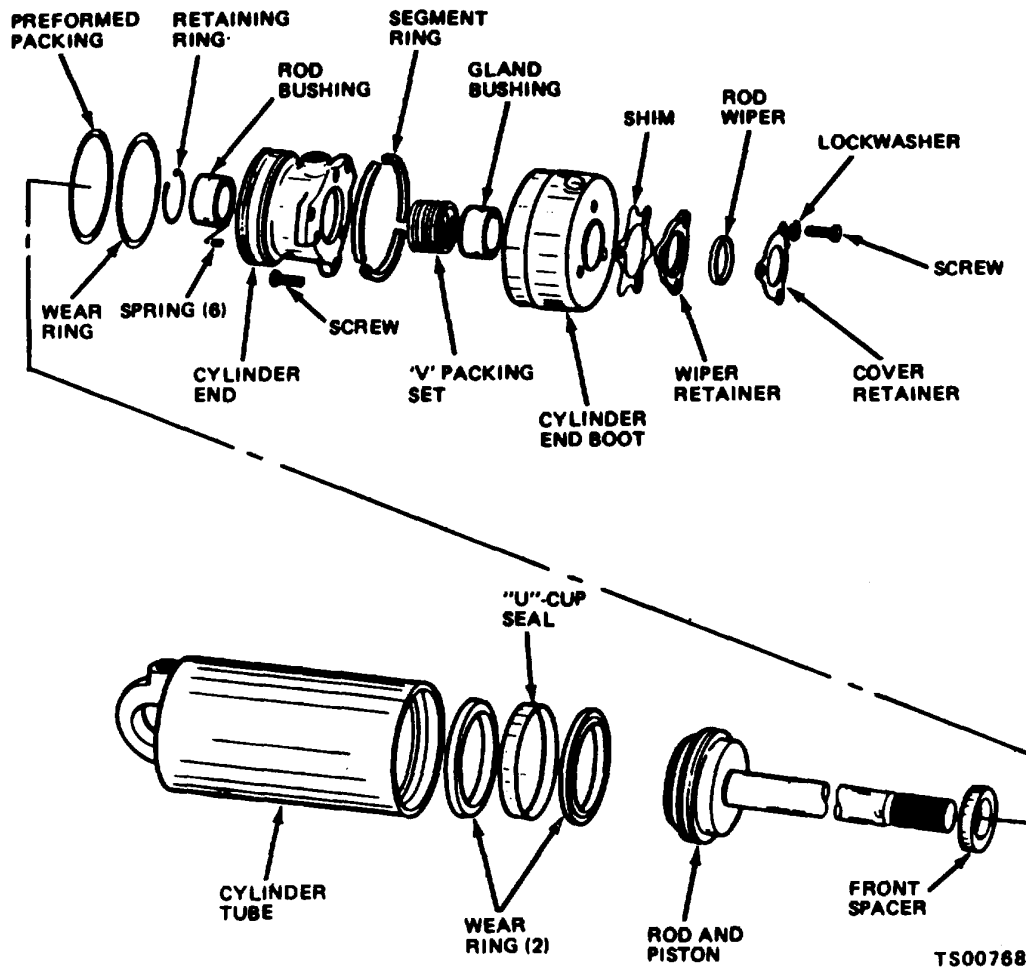

Figure 4-8. Tilt Cylinder, Disassembly and Reassembly

(2) Do not disassemble the tilt cylinder farther than necessary for repair.

**WARNING**

Dry cleaning solvent P-D-680 is toxic and flammable. Wear protective goggles and gloves and use only in a well ventilated area. Avoid contact with skin, eyes, and clothes and don't breath vapors. Do not use near open flame or excessive heat. The flash point is 100°F - 138°F. (38 ° C - 59 ° C). If you become dizzy while using cleaning solvent, get fresh air immediately and get medical aid. If contact with eyes is made, wash your eyes with water and get medical aid immediately.

*c. Cleaning and Inspection.*

(1) Clean the parts of the tilt cylinder with dry cleaning solvent P.D-680. Coat parts with hydraulic fluid after cleaning.

(2) Carefully inspect all parts for serviceability. Replace damaged or worn parts.

*d. Reassembly.*

(1) Reassemble the tilt cylinder as shown in figure 4-8.

*e. Installation.*

(1) Install the tilt cylinder as shown in figure 4-7.

(2) With the engine at fast idle, operate the tilt lever until mast is tilted fully to the rear.

(3) Check degree of rear tilt; this should not exceed 10°. If degree of tilt is not 10°, reposition front rod end to obtain 10°back tilt.

(4) Visually check to see that both sides of mast move back and forth the same distance.

(5) Install cotter pin in front cylinder pin that secures cylinder to upright.

(6) Lubricate the tilt cylinder pins.

(7) Install the floor plates.

**4-26. Hydraulic Lift Chain**

*a. Removal.* Remove the lift chain as shown in figure 4-9.

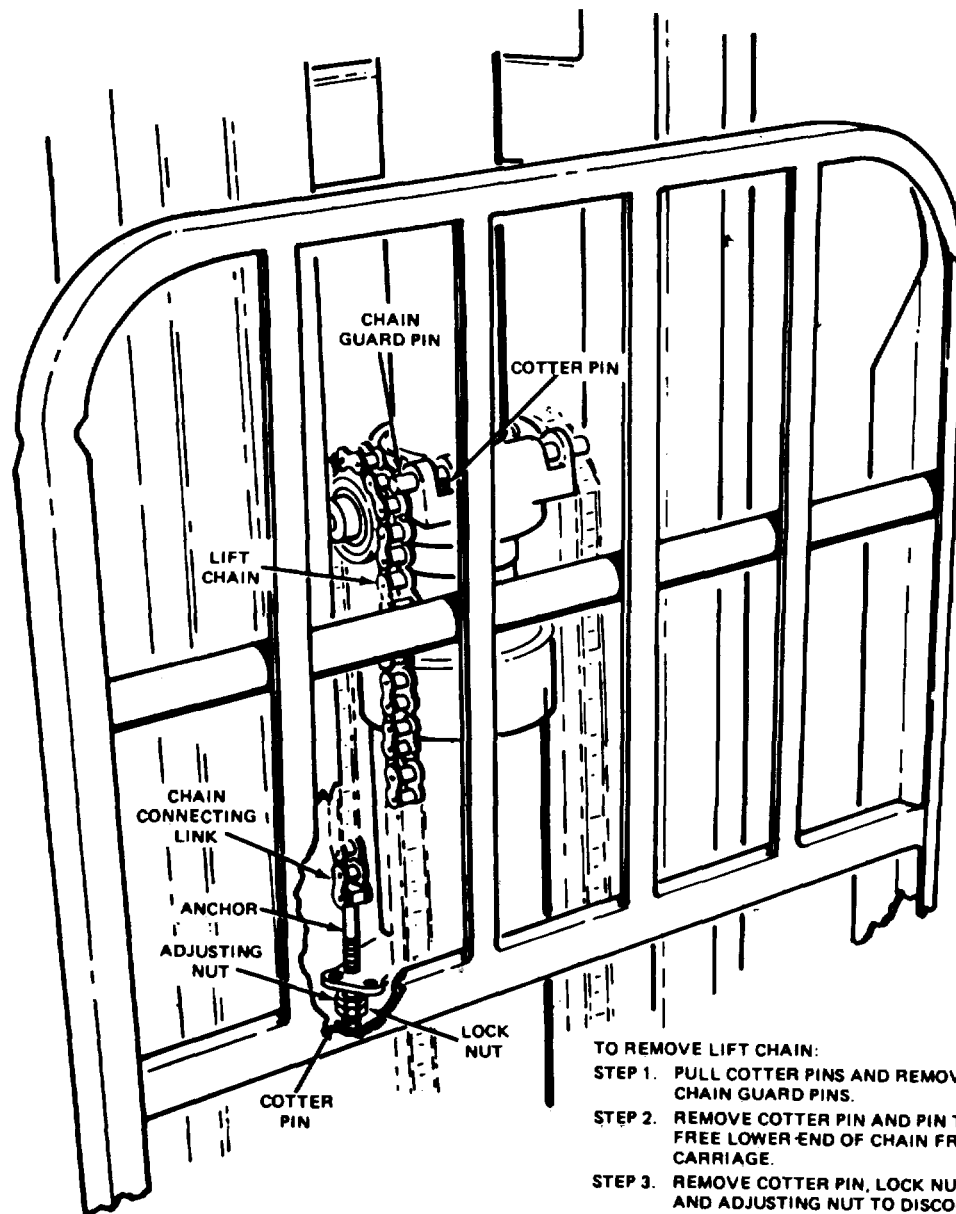

- TO REMOVE LIFT CHAIN:**
- STEP 1. PULL COTTER PINS AND REMOVE CHAIN GUARD PINS.
  - STEP 2. REMOVE COTTER PIN AND PIN TO FREE LOWER END OF CHAIN FROM CARRIAGE.
  - STEP 3. REMOVE COTTER PIN, LOCK NUT, AND ADJUSTING NUT TO DISCONNECT ANCHOR FROM LIFT CYLINDER. LIFT OFF CHAIN.
  - STEP 4. DISCONNECT CHAIN CONNECTING LINK TO RELEASE ANCHOR.

TS007682

Figure 4-9. Lift Chain, Removal and Installation

*b. Cleaning and Inspection.*

- (1) Steam-clean the chains; blow dry with compressed air.
- (2) Thoroughly lubricate the chains using the lubricant indicated in the lubrication chart.
- (3) Inspect the chains for cracked or damaged links, wear, and distortion. Replace damaged chains.
- (4) Inspect the chain anchors for wear, distortion, and damaged threads; replace damaged chain anchors.

*c. Installation.*

- (1) Install the lift chain as shown in figure 9.
- (2) Adjust the hydraulic lift chain as directed in subparagraph *d* below.

*d. Adjustment.*

- (1) Check the lift chain adjustment as shown in figure 4-10.

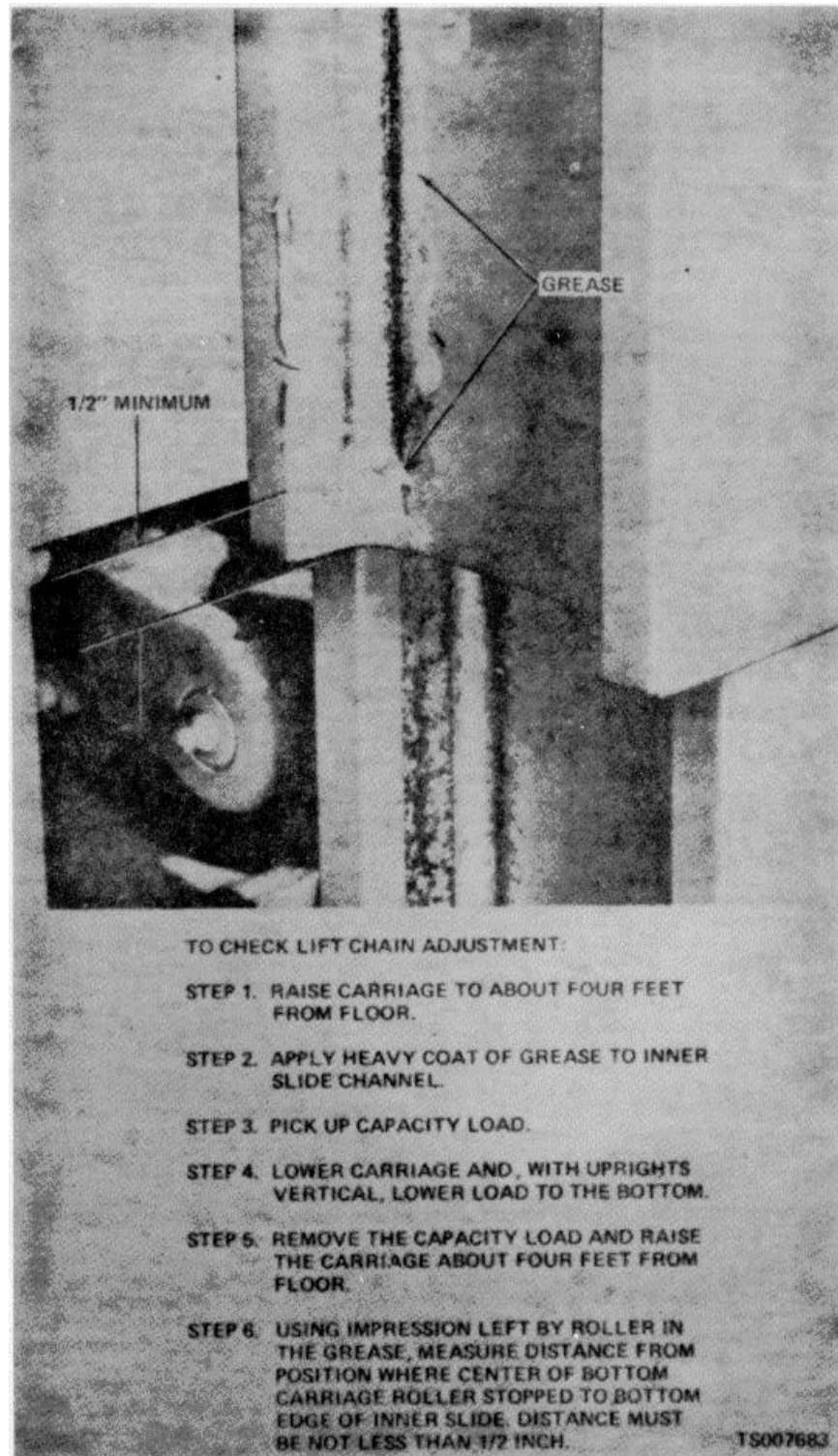

Figure 4-10. Checking Lift Chain Adjustment

(2) If adjustment is incorrect, loosen the locknuts (fig. 4-9) and turn the adjusting nuts to meet the requirement. Chain length must be the same on each side.

(3) Lock the adjusting nuts with the locknuts.

#### 4-27. Hydraulic Lines and Fittings

a. *Removal.* Drain the hydraulic oil tank. Disconnect and remove the hydraulic lines and fittings as shown in figure 4-11.

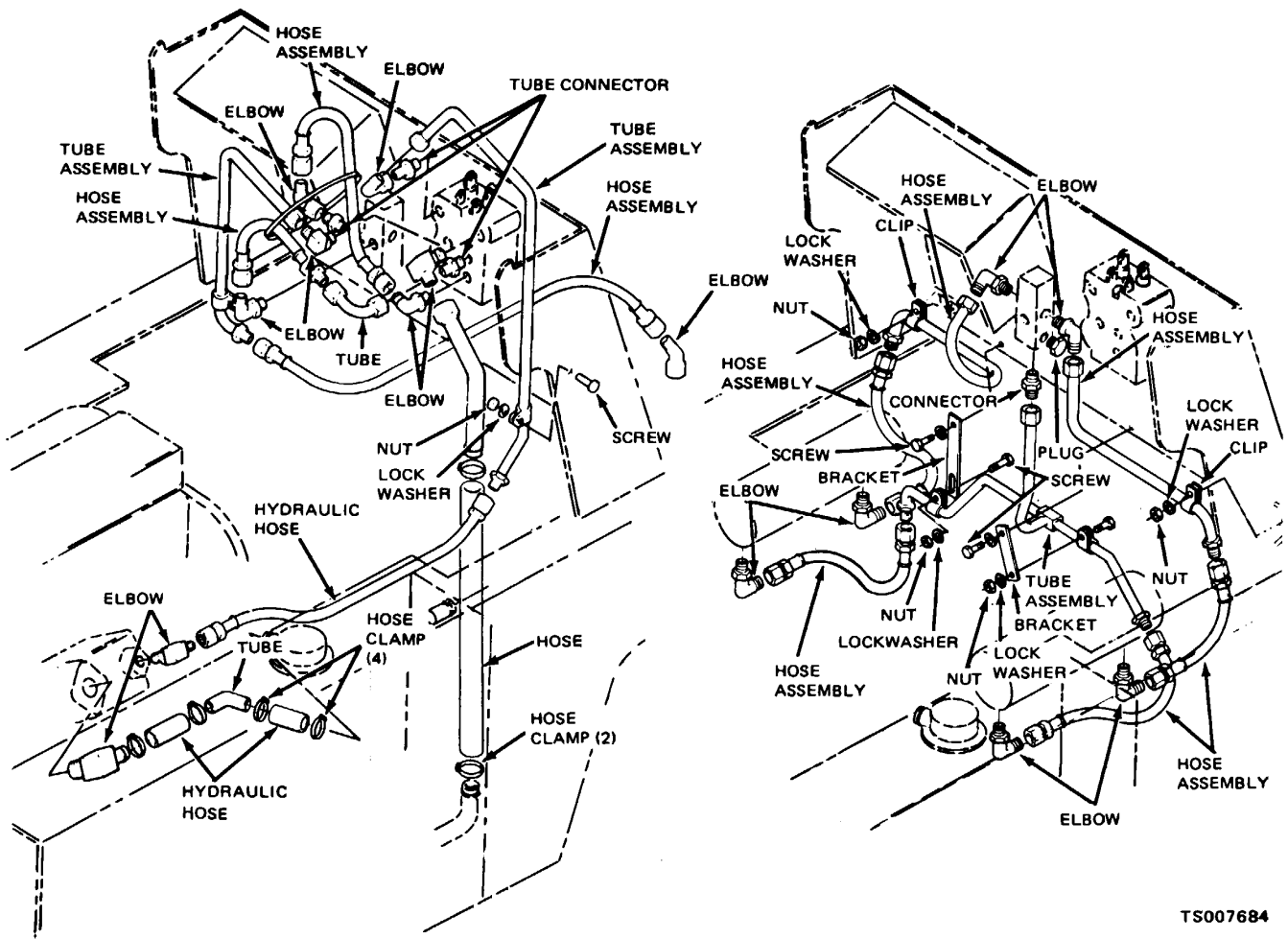

TS007684

Figure 4-11. Hydraulic Lines, Removal and Installation

**WARNING**

Dry cleaning solvent, P-D-680, used to clean parts is potentially dangerous to personnel and property. Avoid repeated and prolonged skin contact. Do not use near open flame or excessive heat. Flash point of solvent is 100°F. -138°F. (38°C. - 60°C.).

*b. Cleaning and Inspection.*

(1) Discard and replace all preformed packings.

(2) Clean hoses and tubes by wiping the exterior with a cloth dampened with dry cleaning solvent P-D-680. Flush the interior of the hoses and tubes with solvent. Blow out with compressed air.

(3) Clean all remaining parts with an approved cleaning solvent; dry thoroughly.

(4) Inspect hoses for cracks, abrasions, collapsed walls, deterioration, damaged threads, signs of leaking, and other damage. Replace damaged hoses.

(5) Inspect tubes for cracks, dents, collapsed walls, and damaged fittings. Replace damaged tubes.

(6) Inspect all other parts for cracks, damaged threads, distortion, deterioration, and other

damage. Replace damaged parts.

*c. Installation.* Install the hydraulic lines and fittings as shown in figure 4-11. Fill the hydraulic oil tank as directed in paragraph 4-28. Start the engine and operate the hydraulic controls. Check the entire system for leaks. Correct any deficiencies.

**4-28. Hydraulic Oil Tank and Filter.***a. Draining Tank.*

(1) Lower the carriage until it is resting on the floor.

(2) Place a large container under the oil tank and remove the drain plug.

(3) Remove the hydraulic oil tank air cleaner; allow the tank to drain.

**CAUTION**

Do not run the engine while the hydraulic oil tank is empty. Damage to the hydraulic pump could result.

*b. Disassembly.*

(1) Disconnect the hydraulic hose from the hydraulic oil filter.

(2) Disassemble the hydraulic oil filter from the tank as shown in figure 4-12.

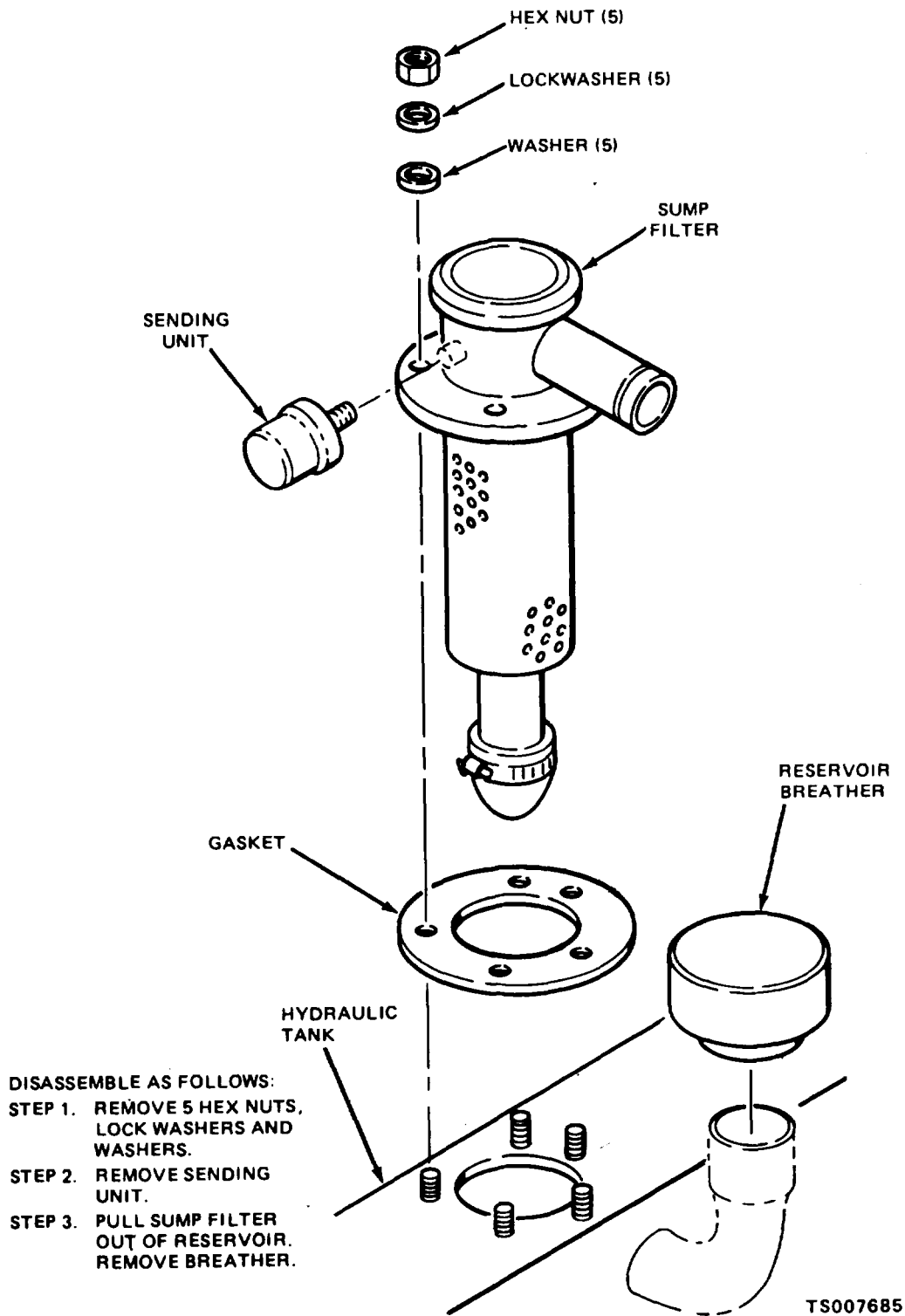

Figure 4-12. Hydraulic Oil Filter, Disassembly and Reassembly

**WARNING**

Dry cleaning solvent, P-D-680, used to clean parts is potentially dangerous to personnel and property. Avoid repeated

and prolonged skin contact. Do not use near open flame or excessive heat. Flash point of solvent is 100°F. -138°F. (38°C. - 60°C.).

*c. Cleaning.*

(1) Discard and replace the filter element and gaskets.

(2) Clean metal filter components with dry cleaning solvent P-D-680; dry with clean, dry compressed air. Clean the interior of the hydraulic tank with a clean cloth. Rinse with 2 quarts of hydraulic oil.

(3) Inspect the filter case for cracks, distortion, damaged mounting flange, and other damage; replace if damaged.

(4) Inspect the cover for cracks, scored or damaged outlet connection, studs that are loose or have damaged threads, or a damaged mounting flange.

*d. Reassembly.* Reassemble the filter as shown in figure 4-12.

*e. Refilling Hydraulic Tank.* Fill the hydraulic tank to the bottom of the filler tube. With the engine at

idle speed, raise and lower the carriage and operate the tilt cylinder. Refill the hydraulic tank. Check for leaks.

**4-29. Hydraulic Reservoir Breather**

*a. Removal.* Remove the hydraulic reservoir breather (fig. 4-12) by unscrewing it from the hydraulic reservoir filler pipe.

*b. Cleaning.* Clean the hydraulic reservoir breather by tapping it on a wood block or bench while rotating the breather. This procedure is intended to dislodge particles caught in the air filter. Replace the breather after it has been in service for 500 operating hours.

*c. Installation.* Install as shown in figure 4-12.

**Section XIII. ELECTRICAL SYSTEM**

**4-30. General**

The electrical wiring diagram for the fork lift truck is shown in figure 1-3. Power to operate the starting motor is supplied by a 12-volt battery. When the starter and ignition switch is turned to START, the starter relay is energized, provided the direction control lever is in neutral so that the neutral start switch is closed. The starter relay closes the circuit that energizes the starter solenoid. The starter solenoid then completes a circuit from the battery to the starting motor to crank the engine. When the engine is running, it turns the generator which recharges the battery. An ammeter on the instrument panel indicates the rate of charge. The headlight and taillight are operated by the light switch mounted on the instrument panel. The stoplight is operated by a pressure switch mounted on the brake master cylinder. This circuit closes only when the starter and ignition switch is in the run position.

**4-31. Alternator**

*a. Test.*

(1) To test alternator output, make meter connections as shown in figure 4-13. The carbon pile rheostat across the battery terminals provides an artificial load for the alternator to work against. Run engine up to governed speed and check alternator output. Output should be: 8 Amps @ 80°F.-500 Engine RPM; 31 Amps @ 80°F.-2200 Engine RPM.

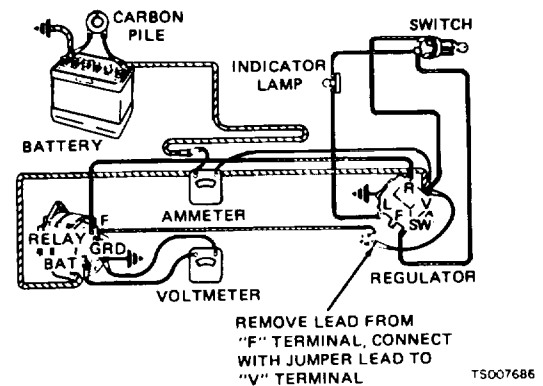

Figure 4-13. Alternator Output Test Setup

(2) To check operation of field relay, make meter connections as shown in figure 4-14, connecting the voltmeter from field terminal of regulator to ground. Turn on ignition switch, but do not start engine. The voltmeter should indicate battery voltage. If the voltmeter indicates zero, the field relay is defective.



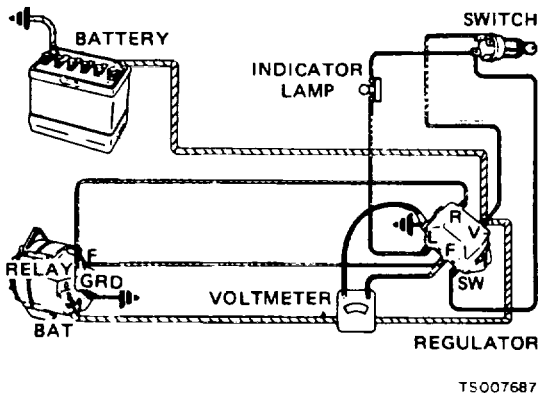

Figure 4-14. Checking Field Relay

(3) To check for excessive circuit resistance, connect a voltmeter from the positive battery post to the field terminal of the alternator. Turn on ignition switch but do not start engine. Check voltmeter readings as follows:

(a) If reading exceeds 0.3 volts, excessive line resistance is indicated. Clean and tighten all connections at and between battery insulated post and regulator "V" terminal, and at regulator "F" terminal and alternator field terminal.

(b) If voltage reading still exceeds 0.3 volts, clean the alternator "Bat" terminal, field relay contacts and voltage regulator contacts.

(c) If the voltage reading still exceeds 0.3 volts, check the alternator for shorted or grounded fields. Remove lead from alternator field terminal and connect an ammeter in series with the field winding.

*b. Alternator Removal*

(1) Tag the electrical leads to the alternator terminals. Disconnect the leads.

**CAUTION**

Always disconnect the battery cable from the positive battery terminal before making electrical repairs to the truck.

(2) Loosen the fan and alternator belts and remove the alternator as shown in figure 4-39.

*c. Installation*

**CAUTION**

Improper location of the lower mounting bolt spacers will cause pulley misalignment and premature belt wear.

Install the alternator in reverse order of removal. Spacers on the lower mounting bolt are placed between the alternator and the rear mounting bracket. These spacers provide for proper alternator to water pump pulley alignment.

**4-32. Voltage Regulator**

*a. Testing and Adjustment.* Figure 4-15 illustrates the voltage regulator with the cover removed to identify the internal parts of the regulator.

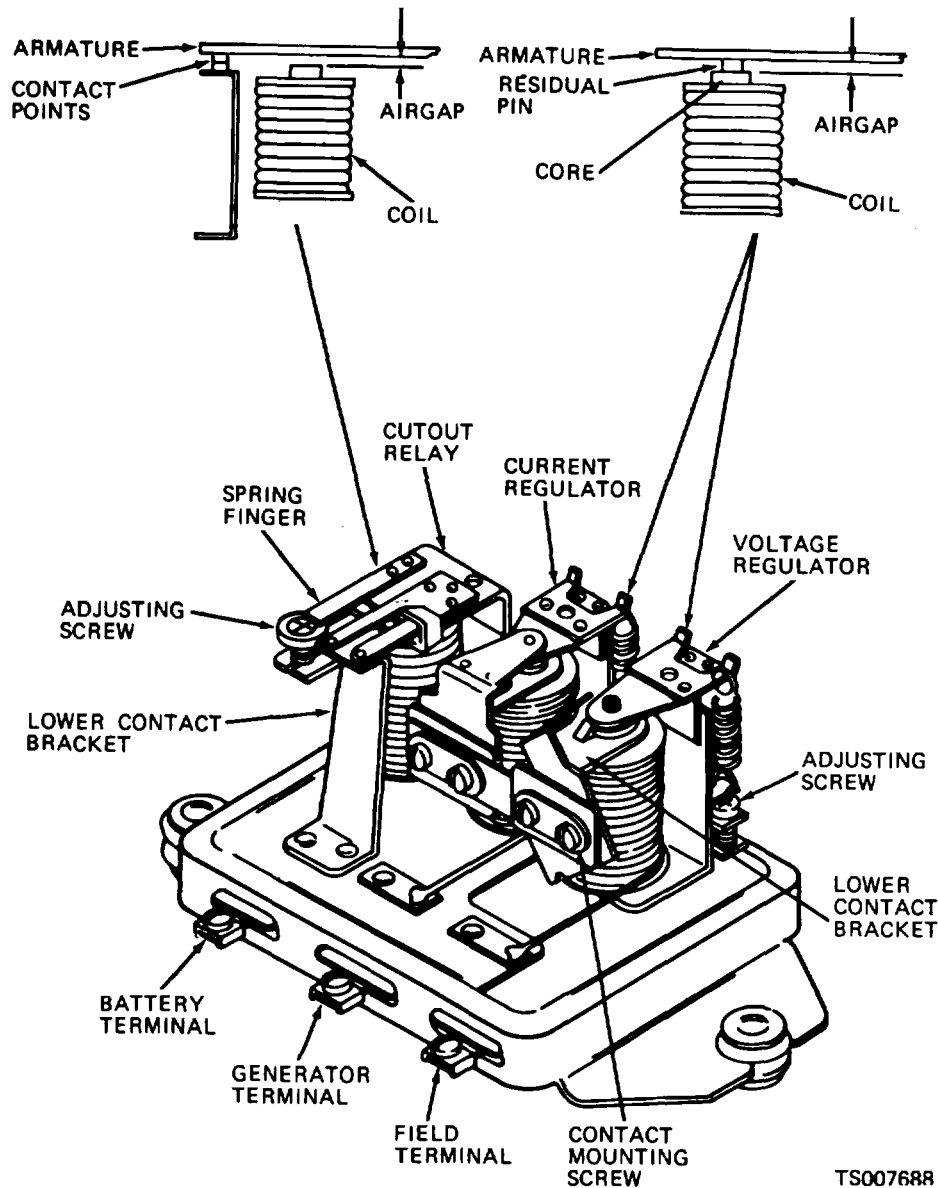

Figure 4-15. Voltage Regulator, Cover Removed

(1) Remove two screws that secure the cover to the regulator base assembly; remove the cover.

**NOTE**

The regulator must be in operating position when being adjusted or tested. Power to the regulator must be shut off when making adjustments. All tests must be made with the regulator at operating temperature (table

4-3). Replace the cover after each adjustment and operate the alternator until the regulator returns to its normal operating temperature. The voltage and current regulator tests must be made with the alternator speed equal to the maximum speed reached by the engine in service.

Table 4-3. Temperature-Voltage and Temperature-Current Chart for Adjusting Voltage Regulator

|   |           |           |           |           |           |           |           |
|---|-----------|-----------|-----------|-----------|-----------|-----------|-----------|
| Ambient temperature of regulator (°F.)            | 65        | 85        | 105       | 125       | 145       | 165       | 185       |
| Voltage setting (volts) connect per figure 4-25   | 14.4-15.4 | 14.2-15.2 | 14.0-14.9 | 13.8-14.7 | 13.5-14.3 | 13.1-13.9 |           |
| Current setting (amperes) connect per figure 4-26 | 25-30     | 24.5-20   | 23.5-28   | 23-27     | 21.5-25.5 | 20.5-24.5 | 19.5-23.5 |

**WARNING**

Dry cleaning solvent, P-D680, used to clean parts is potentially dangerous to personnel and property. Avoid repeated and prolonged skin contact. Do not use near open flame or excessive heat. Flash point of solvent is 100°F. -138°F. (38°C. -60°C.).

(2) Clean the contact points of the regulator when they show signs of oxidation and pitting. Oxidation of the contacts reduces the generator output. Clean the thicker (tungsten) contact points with a riffler file until the oxidation is removed. Clean the thinner (platinum) contact with crocus cloth; wash with dry cleaning solvent P-D-680 to remove any oily film. Blow the filings from the unit with compressed air to prevent them from becoming embedded in the contact surfaces.

**CAUTION**

Do not file the contact points excessively. Never use sandpaper or emery cloth. Use a clean ignition file.

**CAUTION**

Check airgap and point gap opening with the battery disconnected.

(3) Test and adjust the cutout relays as follows:

(a) Measure the airgap of the cutout relay between the armature and the core with the contact points barely touching. The airgap should be 0.020 inch. If the points do not close, align the lower contact bracket slightly or bend the spring fingers on the armature until the points meet and align. Adjust the airgap by loosening the two screws attaching the lower contact bracket. Raise or lower the contact bracket as required. Align the contact points and tighten the screws. Measure the contact point opening; it should be 0.020 inch. Adjust to obtain the correct contact point opening by bending the upper armature stop. To test the closing voltage, connect the regulator as shown in figure 4-16.

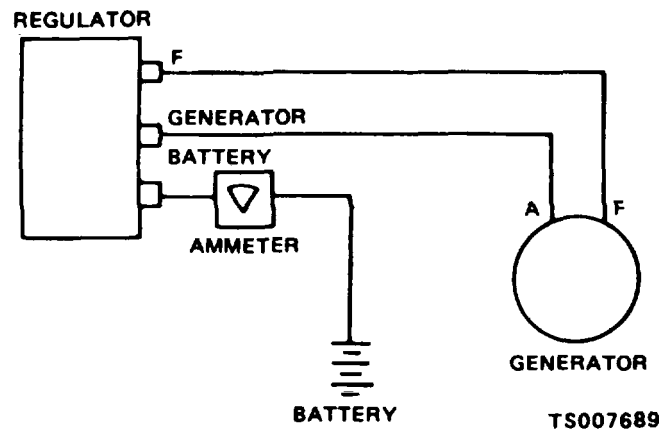

Figure 4-16. Cutout Relay Closing Voltage Test Circuit

**CAUTION**

Never close the cutout relay contact points by hand with the battery connected to the

voltage regulator. This will cause high current to flow through the units and seriously damage them.

(b) Gradually increase the speed of the alternator until the relay contacts close. Note the voltage; it should be between 11.8 and 13.5 volts. If the closing voltage is not within this range, adjust by turning the adjusting screw on top of the cutout relay.

**CAUTION**

Cycle the alternator before each test and adjustment by reducing the alternator speed until the cutout relay opens; then increase the speed slowly until the proper speed for testing is reached.

(4) Test and adjust the voltage regulator as follows:

(a) Measure the voltage regulator airgap. Push the armature down until the points open; release until the points barely close. Measure the airgap at the point between the armature and the part of the core next to the residual pin. The airgap should be 0.075 inch. Adjust by loosening the contact mounting screws, inserting a 0.075-inch thick flat gage in the airgap. Position the contacts so they barely touch; secure the contact mounting screws. Connect the regulator as shown in figure 4-17.

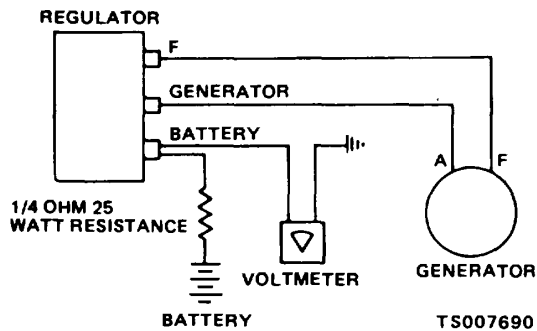

Figure 4-17. Voltage Regulator Setting Test Circuit

**CAUTION**

Make sure the ends of the leads are insulated from the ground at all times to avoid a short circuit.

(b) Cycle the alternator as directed in subparagraph (3). With the alternator operating at 4000 RPM and the regulator at operating temperature, note the voltage registered on the voltmeter; it should be as indicated in table 4-3. If the voltage is not within this range, adjust by turning the adjusting screw at the back of the voltage regulator. Cycle the alternator after each change or adjustment.

(5) Test and adjust the current regulator as follows:

(a) Measure the airgap of the current regulator by the same method used to measure the airgap of the voltage regulator in subparagraph (4) (a). This airgap between the armature and that part of the core next to the residual pin should be 0.075 inch. Adjust the airgap by loosening the contact mounting screws and positioning the contact. Tighten the screws after the proper setting is obtained.

(b) Test the current regulator setting by connecting the regulator as shown in figure 4-18. Prevent voltage regulator from operating during the test by connecting a carbon pile load of approximately the same value as the current regulator setting across the battery terminals during the time the current regulator setting test is made. When the alternator output is increased to maximum, the current should be as shown in table 4-3. If the amperage is not within this range, adjust by rotating screw at the back of the current regulator. After each change of adjustment, reduce the alternator speed until the cutout relay opens; then return to speed and check the current indication on the ammeter.

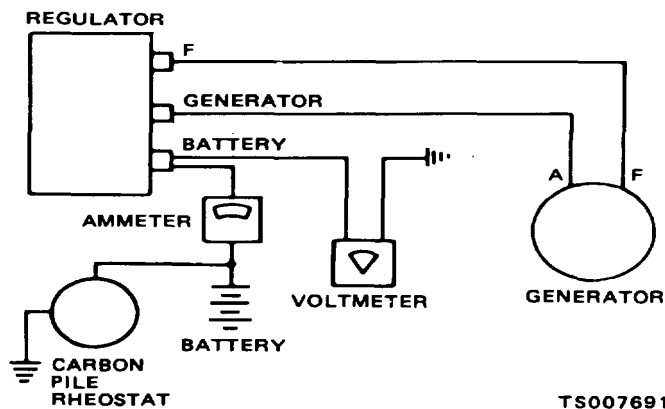

Figure 4-18. Current Regulator Setting Test Circuit

*b. Removal.*

(1) Tag and disconnect the leads to the voltage regulator.

(2) Remove the voltage regulator as shown in figure 4-19.

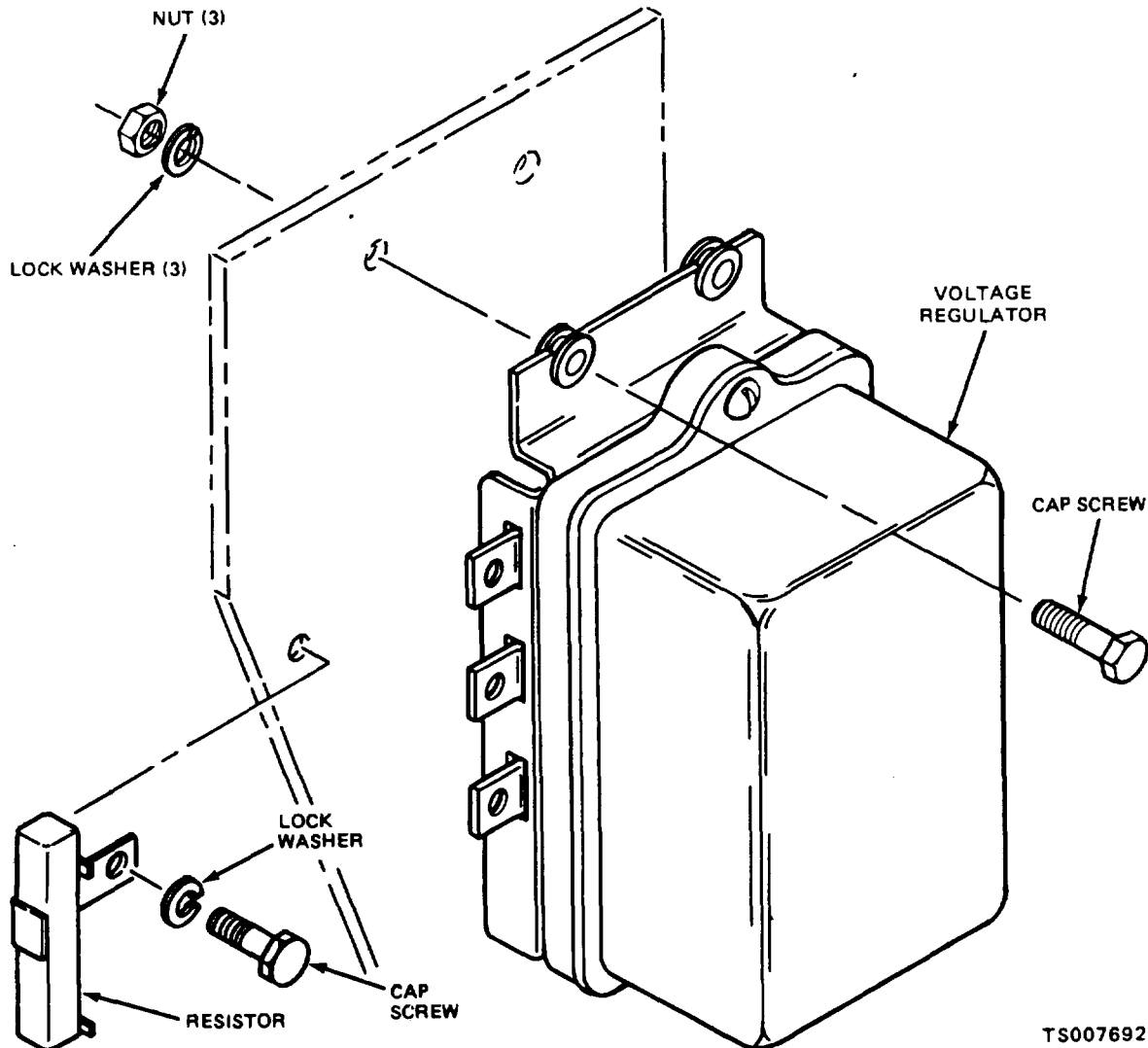

Figure 4-19. Voltage Regulator, Removal and Installation

*c. Installation.*

(1) Install the voltage regulator as shown in figure 4-19.

(2) Connect the electrical leads to the voltage regulator.

(2) Apply parking brake.

(3) Disconnect and tag the electrical leads from the starting motor.

(4) Remove the starting motor from the flywheel housing as shown in figure 4-20. Pull straight out on the starting motor to disengage the pinion gear from the ring gear.

**4-33. Starter Motor**

*a. Removal.*

(1) Disconnect the positive battery cable from the battery.

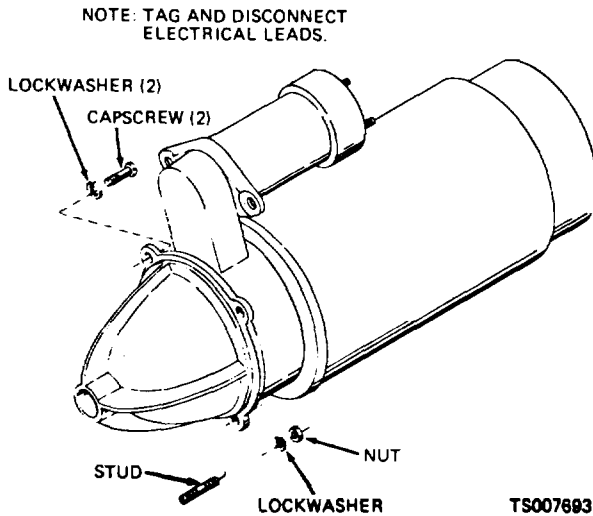

Figure 4-20. Starting Motor, Removal and Installation

**WARNING**

Dry cleaning solvent, P-D680, used to clean parts is potentially dangerous to personnel and property. Avoid repeated and prolonged skin contact. Do not use near open flame or excessive heat. Flash point of solvent is 100°F. -138°F. (38°C. -60°C.).

*b. Cleaning and Inspection.*

(1) Clean the exterior of the starting motor with a cloth dampened with dry cleaning solvent P.D-680; dry thoroughly. Take care to prevent solvent from entering the starting motor.

(2) Inspect the starting motor for cracks, bent or damaged terminals, signs of overheating, damaged pinion teeth, and other damage. Check the

armature shaft for free rotation. Replace if damaged.

*c. Testing.*

(1) Use a battery known to be in good condition and an accurate voltmeter. Connect the positive lead of the voltmeter to the positive terminal of the battery, and the negative lead to the negative (grounded) terminal of the battery. Record the voltage reading.

(2) Pull the high tension lead from the ignition coil to prevent the engine from starting during the starting motor test.

(3) Connect the positive lead of the voltmeter to ground and the negative lead of the voltmeter to starter switch terminal. Turn and hold the ignition switch to the START position and read the voltmeter.

(4) Compare the voltmeter reading with the previously recorded voltmeter reading. If the voltage drop is more than 4 volts, or if the second reading is less than 8 volts, the starting motor is probably faulty.

*d. Installation.*

(1) Install the starting motor as shown in figure 4-20.

(2) Connect the battery cable to the battery and to the starting motor.

(3) Check the operation of the starting motor. Make sure it cranks the engine as required.

**4-34. Ignition Distributor**

*a. Distributor Point, Repair and Replacement.*

(1) To check the distributor points, remove the distributor cap as shown in figure 4-21. Lift the rotor from the distributor shaft and remove the housing cover seal.

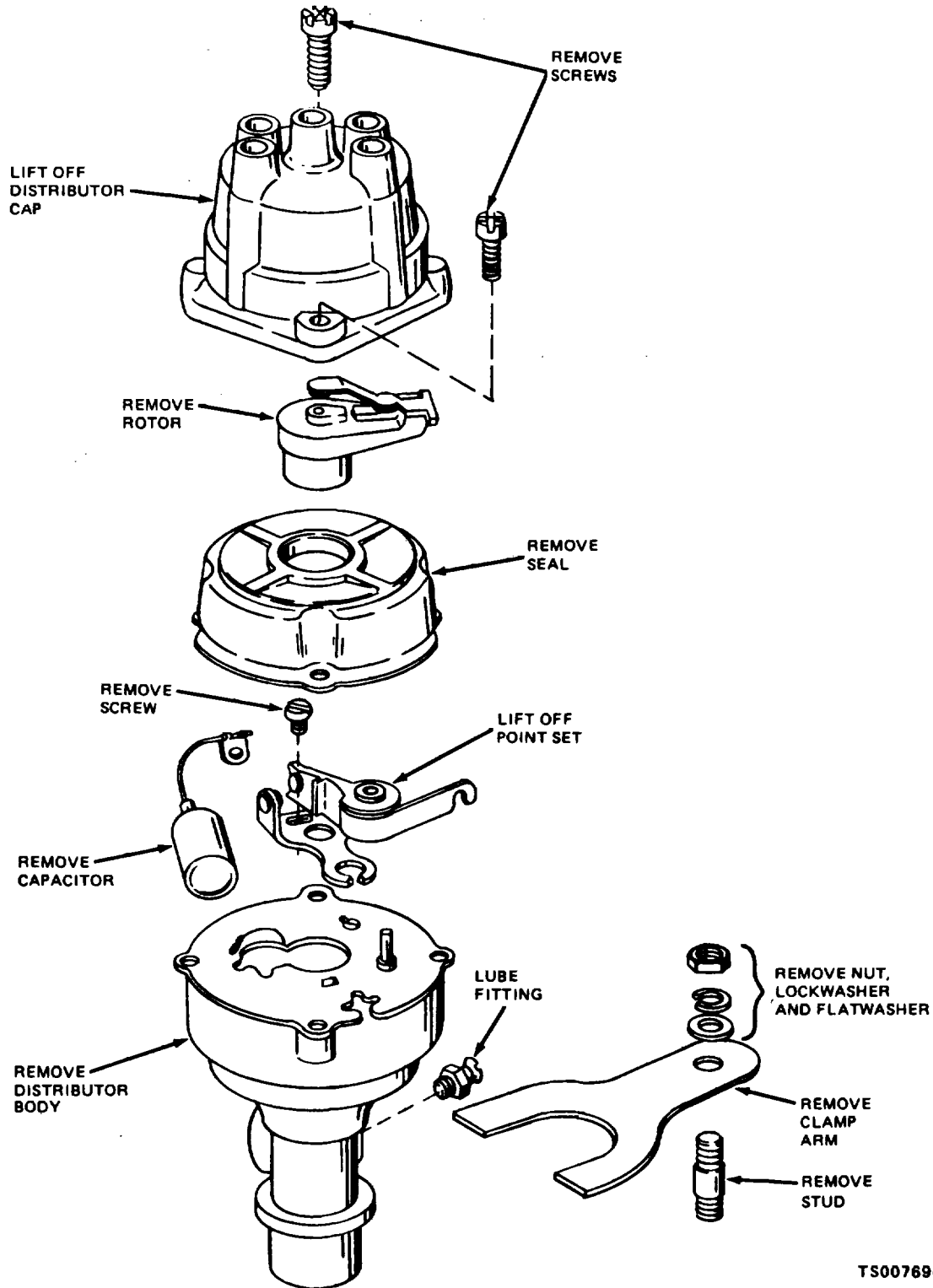

TS007694

Figure 4-21. Distributor, Disassembly and Reassembly

(2) Using the starting motor to crank the engine (with the ignition switch turned OFF), turn over the engine until the contact point cam follower is on the

high point of the cam (points open as far as possible). See figure 4-22.

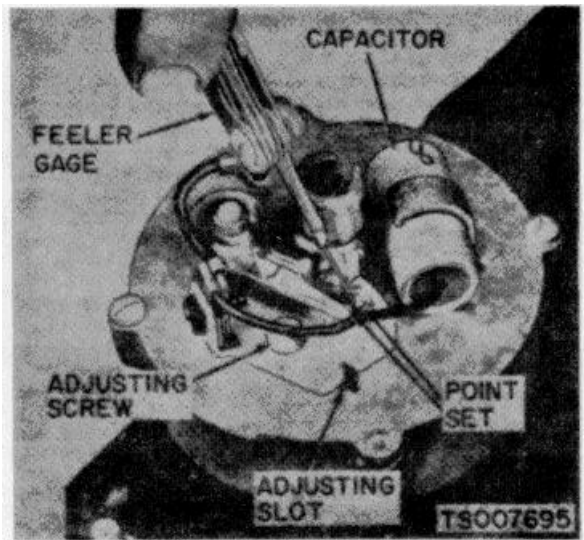

Figure 4-22. Checking Distributor Point Cap

(3) Check the condition of the contact surfaces of the points. If they are rough or pitted, dress them using a contact point file. Remove only the worst roughness. Complete smoothness of the points is not necessary.

(4) If the contact points are badly pitted and burned, replace the points. If the points are good enough for continued service, proceed to subparagraph (8).

(5) Remove the screws that secure the contact set and capacitor to the distributor; remove the parts as shown in figure 4-21.

(6) Install new contact set and capacitor in the same positions from which the old ones were removed.

(7) Using the starting motor to crank the engine, turn over the engine until the contact point cam follower is on the high point of the cam (points open as far as possible); refer to figure 4-22.

(8) Use a wire feeler gage as shown in figure 4-22 to check the point opening. If the point gap is not 0.022 inch, loosen the lock screw with a screwdriver and position the adjusting plate of the point set until the correct point opening is attained. Tighten the lock screw.

(9) Install rotor and install the distributor cap. Make sure all spark plug leads and the ignition coil high tension leads are firmly seated in the distributor cap.

#### b. Removal.

(1) Draw a sketch showing the proper connection of the electrical leads to the distributor. Disconnect the electrical leads.

(2) Remove the distributor as shown in figure

### WARNING

Dry cleaning solvent, P-D-680, used to clean parts is potentially dangerous to personnel and property. Avoid repeated and prolonged skin contact. Do not use near open flame or excessive heat. Flash point of solvent is 100°F. -138°F. (38°C. - 60°C.).

#### c. Cleaning and Inspection.

(1) Clean the distributor with a cloth dampened with dry cleaning solvent P-D-680; dry thoroughly.

(2) Inspect the distributor cap and rotor for cracks, chips, carbon runners, corroded terminals, and burned inserts. Replace the cap and rotor if defective.

(3) Rotate the distributor shaft. It must turn freely without excess play.

(4) Turn the breaker cam slightly in the direction of rotation. The advance springs shall return the cam to the original position without hesitation or catching. If defective, replace the distributor.

#### d. Installation.

(1) Install the distributor as shown in figure 4-21, using the sketch made during disassembly to assure correct wire connection.

(2) Time the distributor as directed in paragraph 4-64a.

### 4-35. Spark Plugs

a. *Removal.* Disconnect the spark plug leads from the spark plugs. Clean the area of the cylinder head around the plugs. Use a spark plug socket wrench to remove the spark plugs.

### WARNING

Dry cleaning solvent, P-D-680, used to clean parts is potentially dangerous to personnel and property. Avoid repeated and prolonged skin contact. Do not use near open flame or excessive heat. Flash point of solvent is 100°F. -138° F. (38°C. - 60°C.).

#### b. Cleaning and Inspection.

(1) Clean the exterior of the spark plugs with a cloth dampened with dry cleaning solvent P-D-680. Use a sand-blast type cleaner, if available, to clean the electrodes.

(2) Inspect the spark plugs for cracked insulation, burned electrodes, and other damage.

(3) Test the spark plugs on a high-voltage tester. A hot, blue spark must arc across the electrodes during the test. Replace shorted plugs.

(4) If the spark plugs are suitable for reuse, check and adjust the spark plug gap. Check the gap on new or used plugs with a wire feeler gage



as shown in figure 4-23. The required gap is 0.030 inch. Adjust the gap to this dimension, if necessary, bending the side electrode only.



Figure 4-23. Checking Spark Gap

c. *Installation.* Install the spark plugs using new gaskets. Tighten to 35 foot-pounds torque. Connect the spark plug leads to the spark plugs.

#### 4-36. Ignition Coil

a. *Testing.* To test the ignition coil, pull the high tension lead from the center contact of the distributor. Hold the lead by the insulation so that the end contact is within ¼ inch of an unpainted, grounded portion of the engine. Turn the starter and ignition switch to START. A hot spark should jump from the high tension terminal to ground as the engine is cranked. If no spark is visible and if all wiring is intact, the coil may be faulty.

b. *Removal.*

(1) Tag and disconnect the electrical leads from the ignition coil. Remove the ignition coil as shown in figure 4-24.

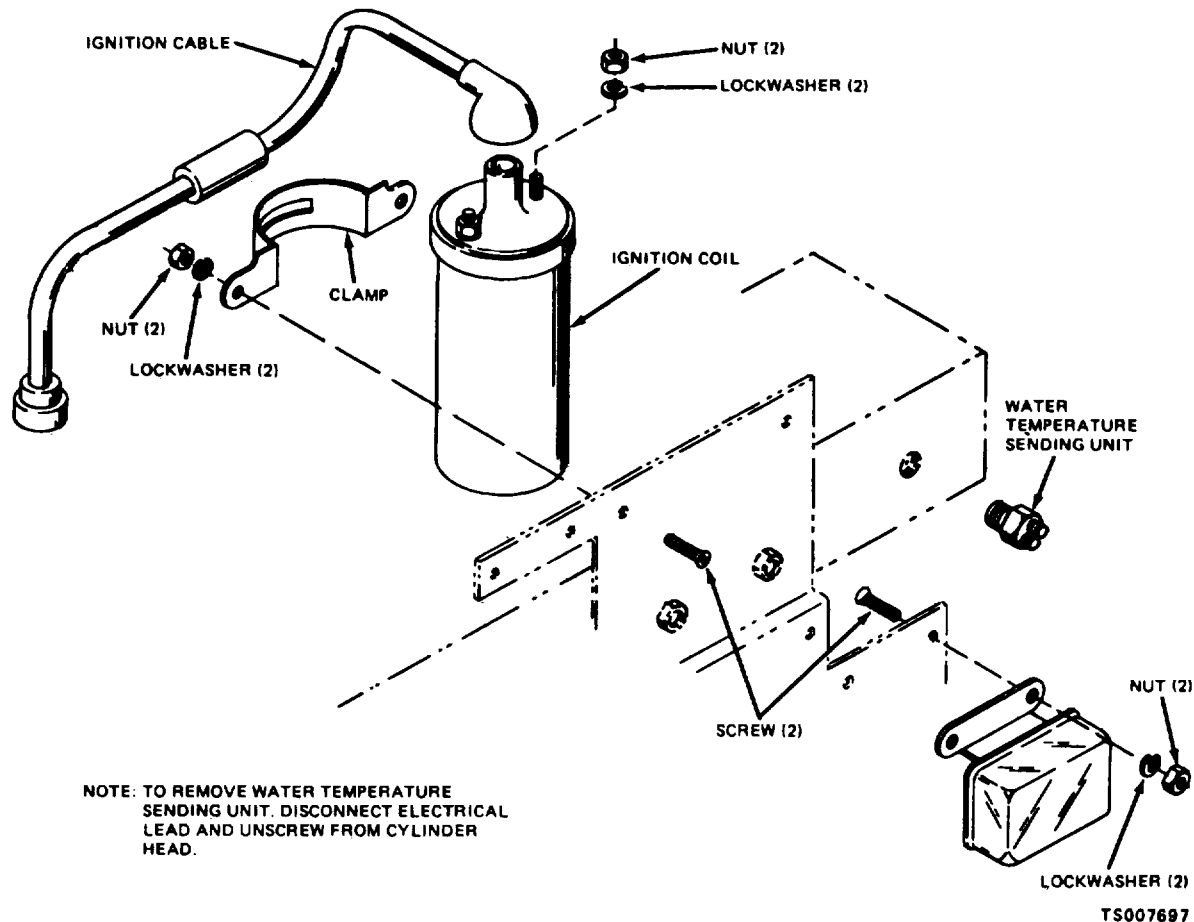

Figure 4-24. Ignition Coil, Removal and Installation

c. *Installation.* Install the ignition coil as shown in figure 4-24. Reconnect the electrical leads to the ignition coil.

**4-37. Battery and Cables**

a. *Battery Cleaning.*

(1) Swing out the right engine side panel and swing out the battery tray to provide access to the battery (fig. 4-25).

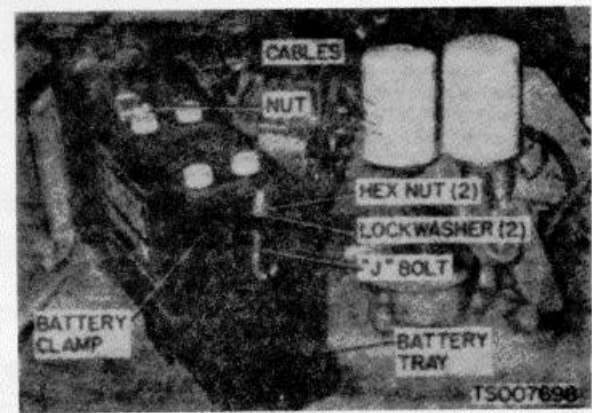

Figure 4-25. Battery and Cables, Removal and Installation

(2) Remove dirt and grease accumulated on the battery with a clean cloth.

(3) Pour a solution of baking soda and water on the top of the battery to neutralize any acid present. Continue to pour until the solution no longer bubbles when it contacts the battery.

(4) Loosen the nuts that secure the battery cables to the battery posts; remove the cables. Clean all corrosion from the cable clamps and posts with a wire brush or jackknife. Replace the cables; tighten the nuts.

**CAUTION**

Remove ground cable first. When installing cables, install ground cable last.

(5) Lightly coat the battery posts and cable clamps with high temperature grease.

b. *Battery Testing.*

(1) Test the state of the electrolyte using a hydrometer. The specific gravity of the electrolyte at 75 °F shall be 1.225 minimum for normal temperature operation or 1.265 minimum for cold temperature operation. For constant operation in above-freezing temperatures, electrolyte strength may be reduced to 1.225 by diluting with distilled water. If the battery is not fully charged, charge it.

(2) Connect a voltmeter across the terminals of the battery, and note the reading. Pull the

high tension cable from the ignition coil, crank the engine with the starter, and note the reading on the voltmeter. If the difference between the two readings is more than 4 volts or the second reading is less than 8 volts, replace the battery.

c. *Battery Removal.*

(1) Loosen the nuts (fig. 4-25) that secure the battery cables to the battery posts; remove the cables.

(2) Remove the battery from the truck as shown in figure 4-25.

d. *Cleaning and Inspection.*

(1) Clean the battery tray and clamp by flushing with a solution of baking soda. Flush parts until bubbling stops when new solution is applied.

(2) Inspect the battery for loose posts, cracks, evidence of leaks, or other damage.

(3) Test the battery as directed in subparagraph b.

e. *Battery Installation.* Install as shown in figure 4-25.

f. *Cable Removal.*

(1) Loosen the nuts (fig. 4-25) that secure the cables to the battery posts; disconnect the cables. Remove the cable clamp that secures the cables to the truck frame.

(2) Remove the starting motor mounting bolt and lockwasher that secure the ground cable to the flywheel housing; remove the cable.

(3) Remove the nut and lockwasher that secure the positive battery cable to the solenoid switch mounted on the starting motor; remove the cable.

**WARNING**

Dry cleaning solvent, P-D-680, used to clean parts is potentially dangerous to personnel and property. Avoid repeated and prolonged skin contact. Do not use near open flame or excessive heat. Flash point of solvent is 100°F. -138°F. (38°C. - 60°C.).

g. *Cleaning and Inspection.*

(1) Clean the cables with a cloth dampened in dry cleaning solvent P-D-680. Clean cable clamps and lugs with a wire brush.

(2) Inspect the cables for damaged insulation, breaks, or other damage.

(3) Inspect cable clamps and lugs for corrosion, distortion, poor connections to cables, or other damage.

(4) Replace cables if defective.

h. *Cable Installation.* Install as shown in figure 4-25. Make sure the negative terminal is connected to ground.

**4-38. Lights, Horn and Wiring**

**4-39. Lights**

*a. Replacement.*

(1) To replace the headlight lamp, remove the two screws (fig. 4-26) that secure the cowl to the

body; remove the cowl and remove and disconnect the sealed lamp. Reverse the procedure to install a new lamp.

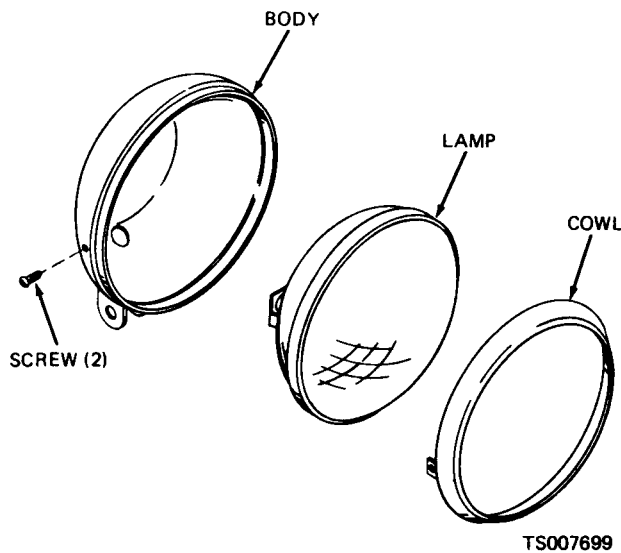
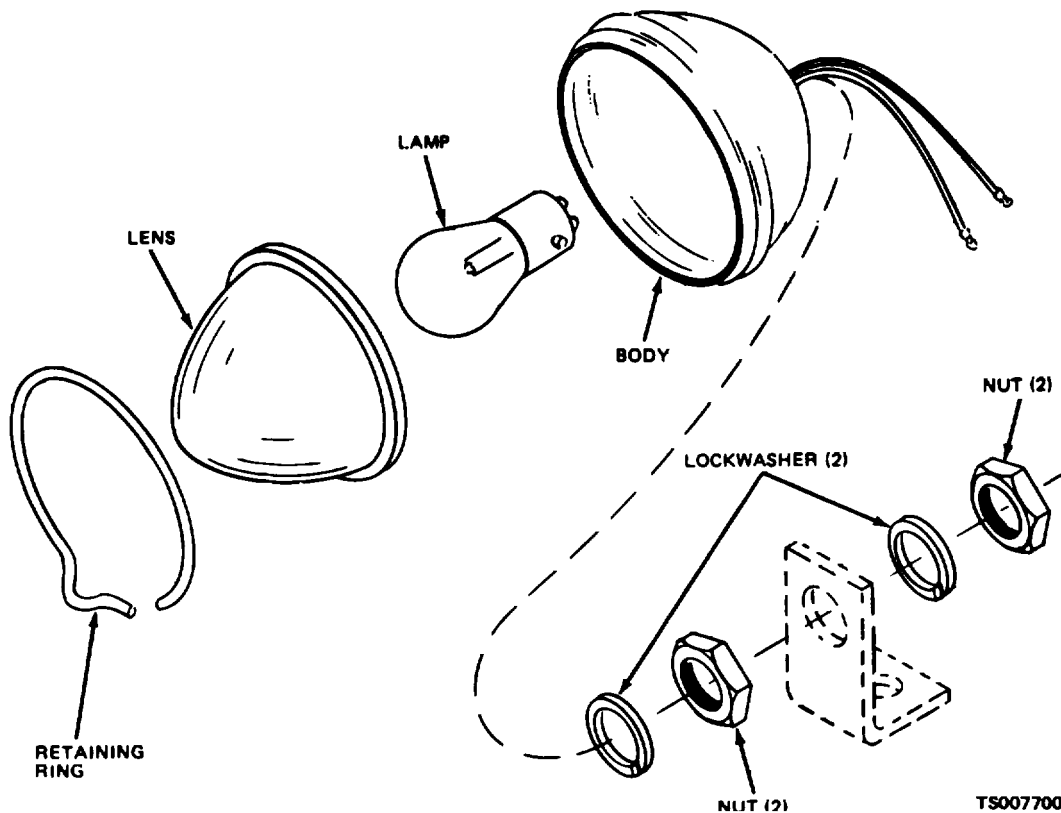

Figure 4-26. Headlight, Disassembly and Reassembly

(2) To replace the taillight lamp, remove the retaining ring (fig. 4-27) and lens from the body. Push in on the lamp and give it a one-quarter turn

counterclockwise to remove it. Reverse the procedure to install a new lamp.



*Figure 4-27. Taillight, Disassembly and Reassembly*

**4-40**

*b. Removal and Disassembly.*

(1) Remove and disassemble the headlight as shown in figure 4-26.

(2) Remove and disassemble the taillight as shown in figure 4-27.

**WARNING**

Dry cleaning solvent, P-D-680, used to clean parts is potentially dangerous to personnel and property. Avoid repeated and prolonged skin contact. Do not use near open flame or excessive heat. Flash point of solvent is 100°F - 138°F (38°C. - 60°C.).

*c. Cleaning and Inspection.*

(1) Clean all parts with a cloth dampened with dry cleaning solvent P-D-680; dry thoroughly.

(2) Inspect the parts for cracks, distortion,

corrosion, and other damage; replace damaged parts.

*d. Reassembly and Installation.*

(1) Reassemble and install the headlight as shown in figure 4-26.

(2) Reassemble and install the taillight as shown in figure 4-27.

**4-40. Horn and Wiring***a. Inspection, Repair and Replacement.*

(1) Visually inspect the horn, horn terminals and wiring for signs of corrosion build-up, wear, and chafing.

(2) Clean terminals on horn, lights and other electrical parts using a stiff bristle brush and a rag. Connect electrical leads and tighten securely.

(3) Check operation of horn and lights. Replace defective horn, lights or wiring.

**Section XIV. FUEL SYSTEM****4-41. General**

a. The fuel system consists of the fuel tank, fuel filter, lines, fuel pump, carburetor, air cleaner, positive crankcase ventilation valve and breather, accelerator pedal and linkage, and governor.

b. Fuel is drawn from the fuel tank, through the fuel filter, by the fuel pump. From the fuel pump, fuel goes to the carburetor where it is combined with air to form a mixture that is combustible in the engine.

c. A positive crankcase ventilation system is provided to minimize the gases discharged to the atmosphere from the crankcase. The positive crankcase ventilation system sucks the crankcase fumes into the intake manifold so that they are burned in the engine. The system consists of a PCV valve (figure 4-28) along with necessary lines and fittings.

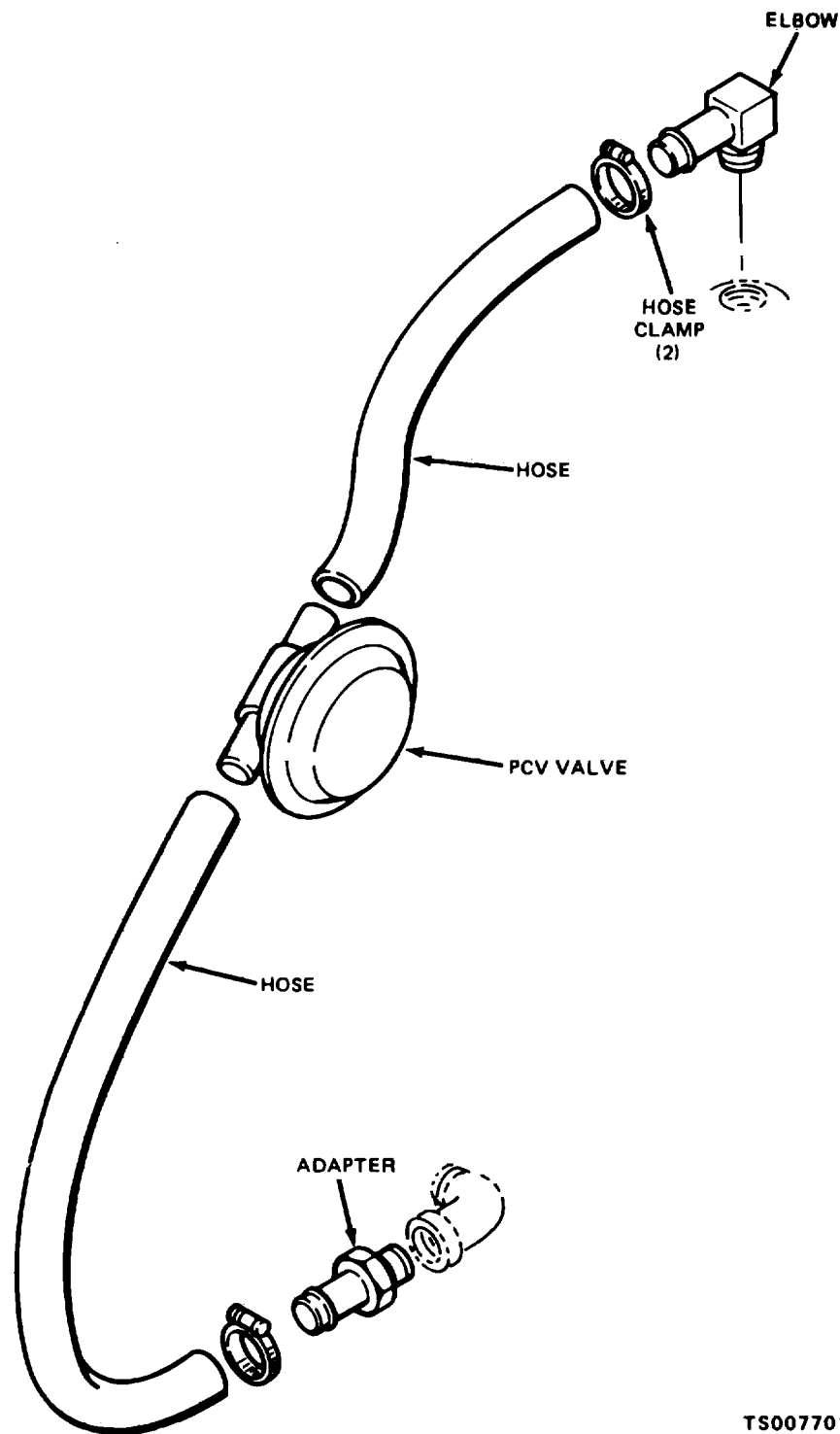

TS007701

Figure 4-28. Positive Crankcase Ventilation Valve and Piping

d. The amount of fuel fed to the engine is controlled by the accelerator pedal and linkage. The governor limits the maximum speed of the engine. The maximum governed speed of the engine is 2600 RPM.

#### 4-42. Carburetor

##### a. Adjustment.

(1) Remove fuel cap (fig. 4-30), seal, and the two bolts and washers securing fuel filter well; remove well.

- (2) Remove a pipe plug from the intake manifold; install an adapter in the pipe plug hole; connect a vacuum gage to the adapter.
- (3) Connect a tachometer to the engine.
- (4) Run the engine at fast idle-until it is at operating temperature.

- (5) Loosen the choke adjusting screw (fig. 4-29); push the choke control knob all the way in; then pull it out about 1/16-inch. Push the choke control lever as far as possible toward the rear of the fork lift truck; secure the choke adjusting screw against the choke wire.

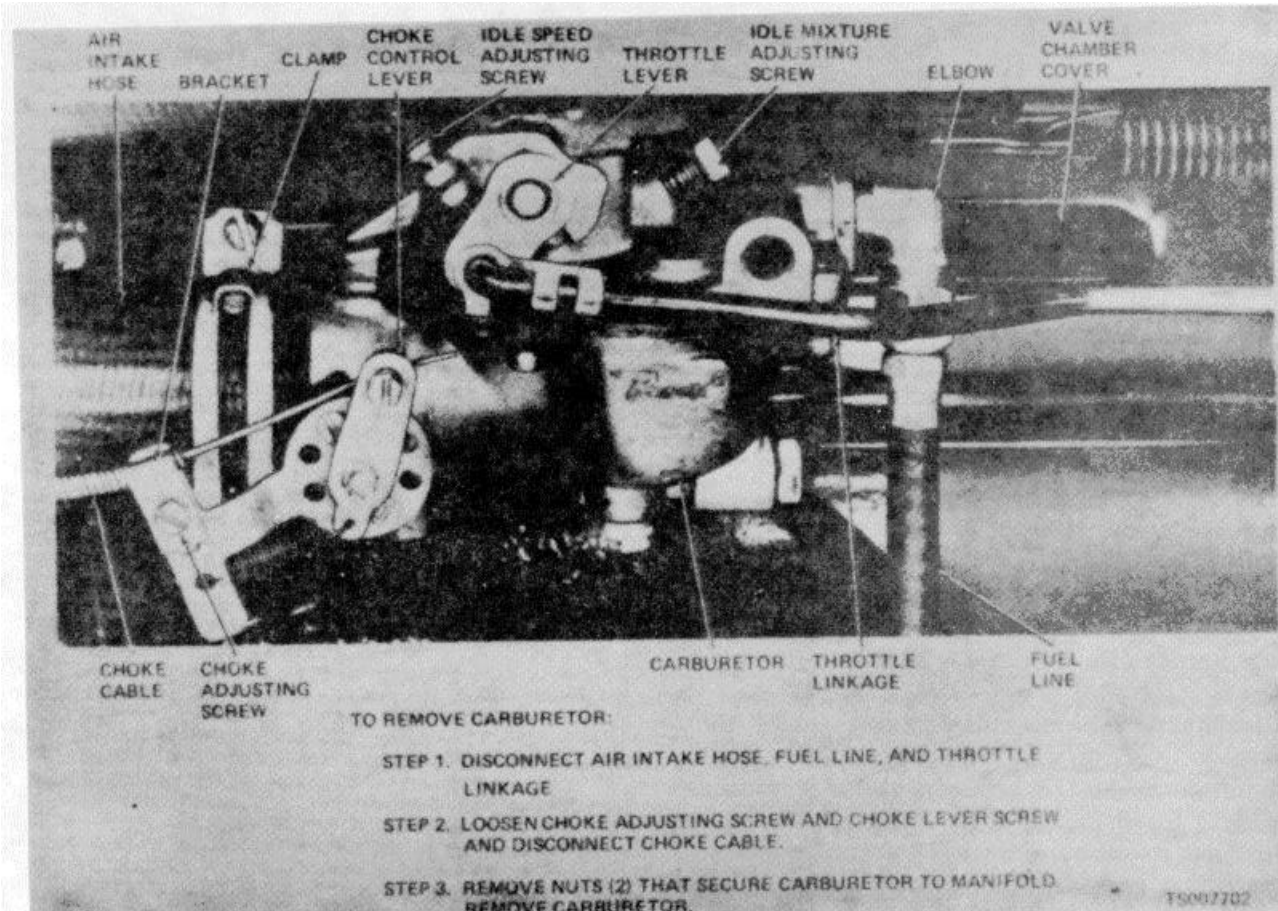
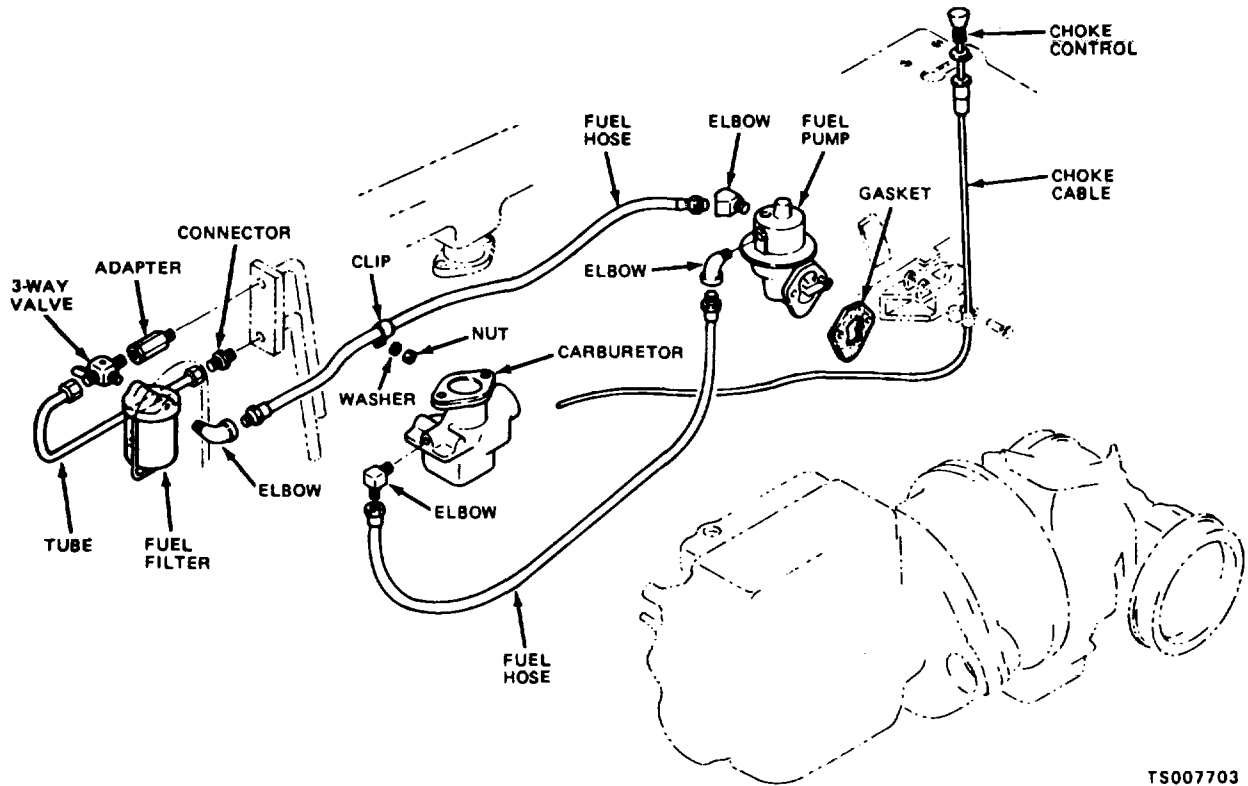

Figure 4-29. Carburetor, Adjustment Points, Removal and Installation

- (6) Set the idle speed adjusting screw for an engine speed of 450 to 500 RPM.
- (7) Set the idle mixture adjusting screw to obtain the highest reading possible on the vacuum gage.
- (8) If engine speed is not between 450 to 500 RPM, reset the engine idle speed as directed in (6) above.

- (9) If any idle speed readjustment is necessary, readjust the idle mixture as directed in (7) above.
  - b. Removal.
    - (1) Remove the fuel cap and well shown in figure 4-30.



TS007703

Figure 4-30. Fuel Filter, Fuel Pump, Lines and Fittings, Removal and Installation

(2) Remove the carburetor as shown in figure 4-29.

c. *Installation.* Using a new gasket, install the carburetor by reversing the removal procedure given in figure 4-29. Tighten carburetor mounting nuts to 15 to 20 foot-pounds. Adjust carburetor as directed in subparagraph a. above.

#### 4-43. Fuel Pump

##### a. *Testing.*

(1) Disconnect the fuel hose (fig. 4-30) from the elbow on the carburetor. Install a tee fitting between the elbow and the fuel line. Connect a 0 to 5 PSI pressure gage to the tee fitting.

(2) Connect a tachometer to the engine.

(3) Operate the engine at 1800 RPM. If the gage does not indicate between 1 ¼ and 2 ¼ PSI

with the gage held 16 inches above the fuel pump, inspect the fuel lines and the filter for obstructions. If the filter and lines are unobstructed, replace the fuel pump.

(4) Remove the tee fitting and tachometer. Connect the fuel line to the elbow.

b. *Removal.* Remove the fuel pump and gasket as shown in figure 4-30.

c. *Installation.* Install the fuel pump using a new gasket as shown in figure 4-30. Torque nuts to 15 to 20 foot-pounds.

#### 4-44. Fuel Filter

##### a. *Servicing.*

(1) Close the three-way valve (fig. 4-30).

(2) Service fuel filter as illustrated in figure

4-31.



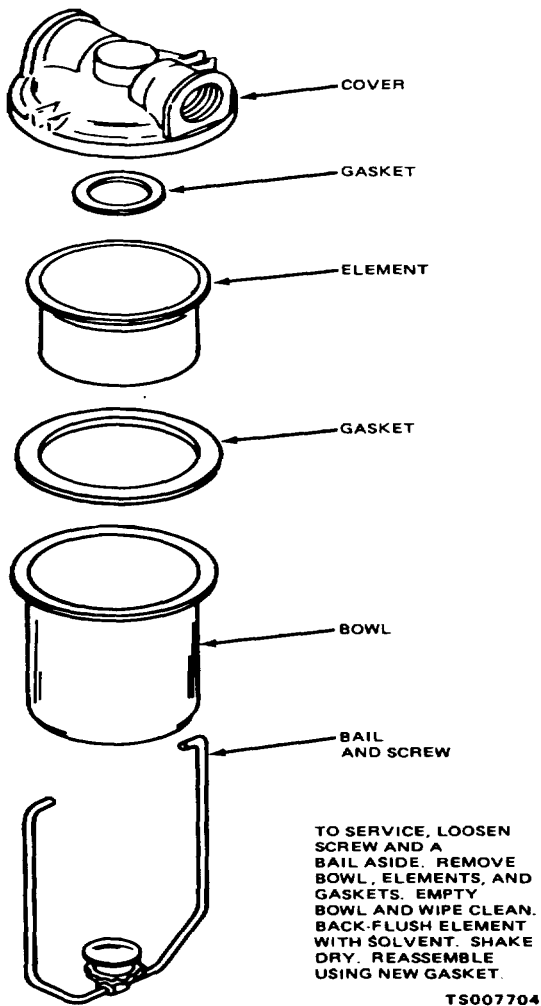

- (3) Open fuel shutoff valve.
- b. *Removal.*
  - (1) Close the three-way valve (fig. 4-30).
  - (2) Remove fuel filter as shown in figure 4-

30.

c. *Installation.* Installation is the reverse of removal. Refer to figure 4-30. Open the fuel shut-off valve.

#### 4-45. Air Cleaner

- a. *Removal.*

- (1) Open left hand engine access door.
- (2) Remove the air cleaner as outlined in figure 4-32.

Figure 4-31. Fuel Filter Service

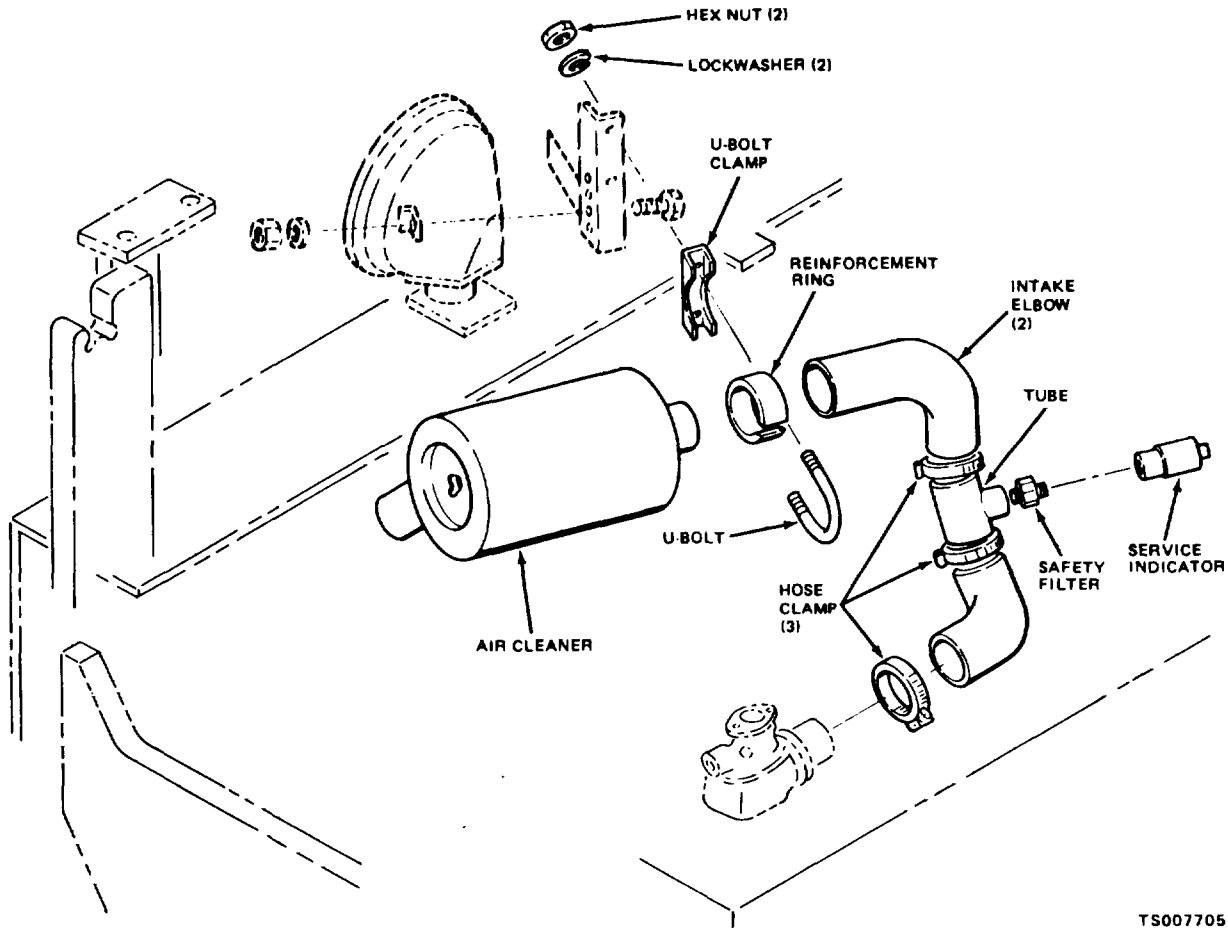

Figure 4-32. Air Cleaner, Removal and Installation

(3) Install the air cleaner as outlined in figure 4-32.

**4-46. Crankcase Breather**

a. The engine used in the fork lift truck incorporates a closed crankcase ventilation system. There is no breather that releases fumes to the atmosphere. The unburned fumes are, instead, piped back into the engine for re-burning.

**4-47. PCV Valve**

a. *Service.*

(1) Remove the PCV valve as shown in figure 4-28. Flush the valve with an approved solvent. Shake free of solvent. Reinstall as shown in figure 4-28.

b. *Removal.*

(1) Remove the PCV valve, lines and fittings as shown in figure 4-28.

c. *Installation.*

(1) Install the PCV valve and related parts as shown in figure 4-28. Replace all unserviceable parts with new parts.

**4-48. Fuel Tank**

a. *Inspection.*

(1) Visually inspect the fuel tank and fuel lines and fittings as shown in figure 4-33.

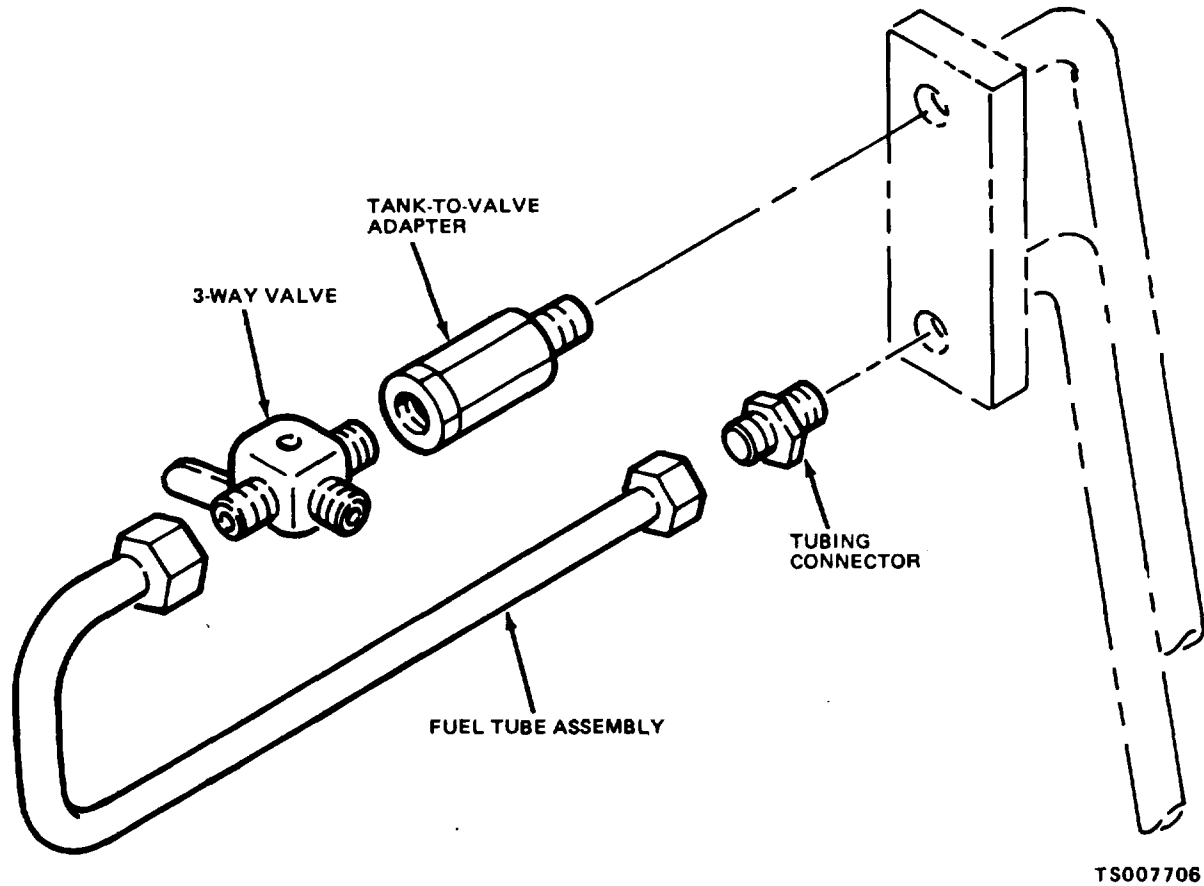

Figure 4-33. Fuel Tank, Lines and Fittings

(2) Tie fuel hoses away from parts that become excessively hot during truck operation.

**4-49. Governor Adjustment**

a. Time the engine (para 4-64, a.) and adjust the carburetor (para 4-42, a.).

b. Disconnect governor spring; see figure 4-34. Back out governor surge screw in engine. Surge screw is located in the edge of the gear cover.

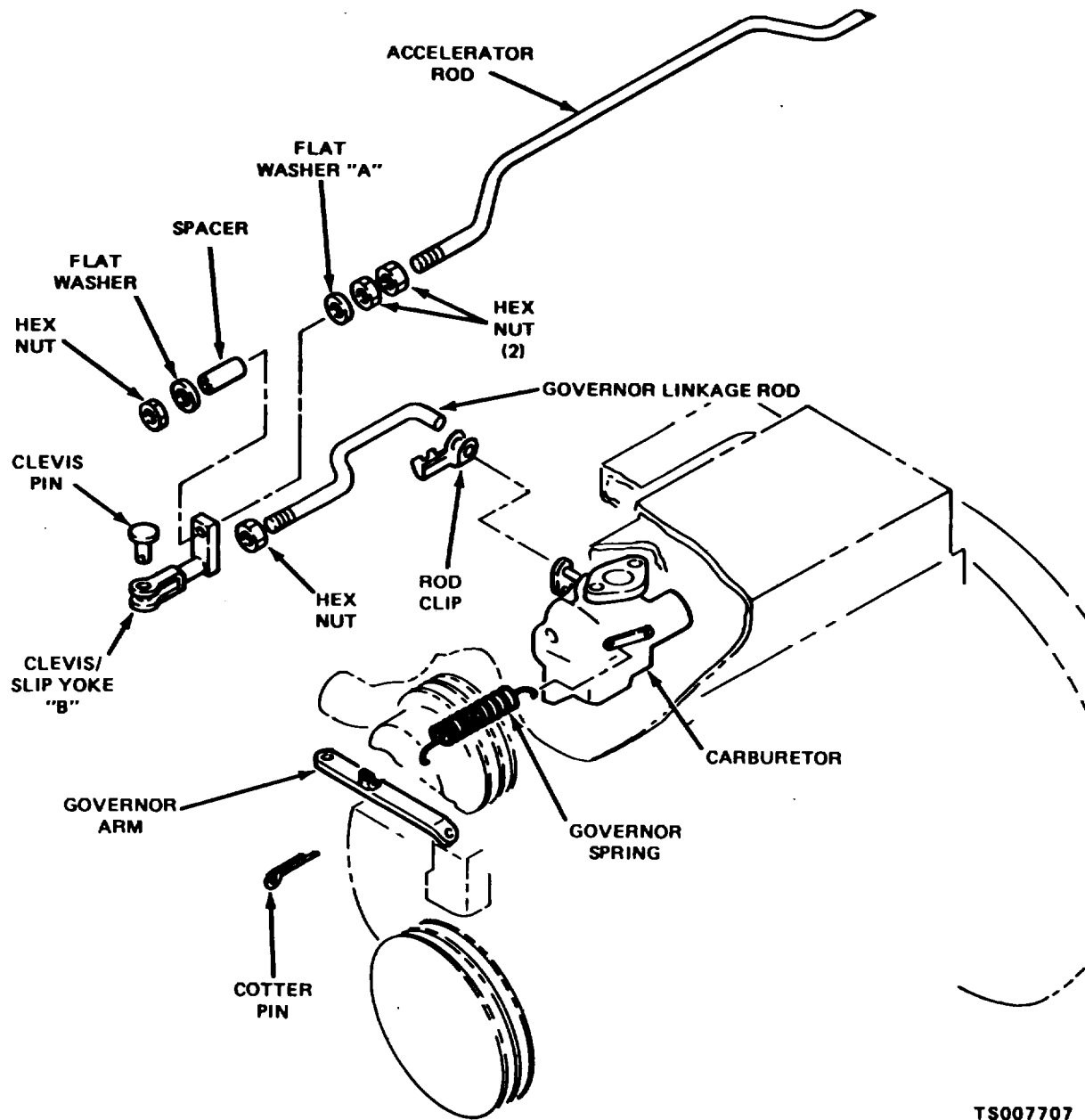

TS007707

Figure 4-34. Governor Adjustment

- c. Move governor arm to full idle position.
- d. Adjust governor surge screw inward until it just moves governor arm. Lock in place with locknut.
- e. Install governor-to-carburetor linkage rod in full throttle position and adjust to approximately 1/16-inch gap between carburetor stop pin and throttle arm stop.
- f. Install governor spring and adjust no load engine speed to 2600 RPM.

- g. Depress accelerator pedal (fig. 4-84) to pedal stop. Adjust accelerator slip yoke mechanism so that washer "A" moves away from slip yoke "B" 1/8-inch. Tighten all nuts.
- h. Adjust engine idle speed to 600/660 RPM.

#### 4-50. Accelerator Pedal and Linkage

- a. *Removal and Disassembly.* Remove and disassemble the accelerator pedal and linkage as shown in figure 4-35.

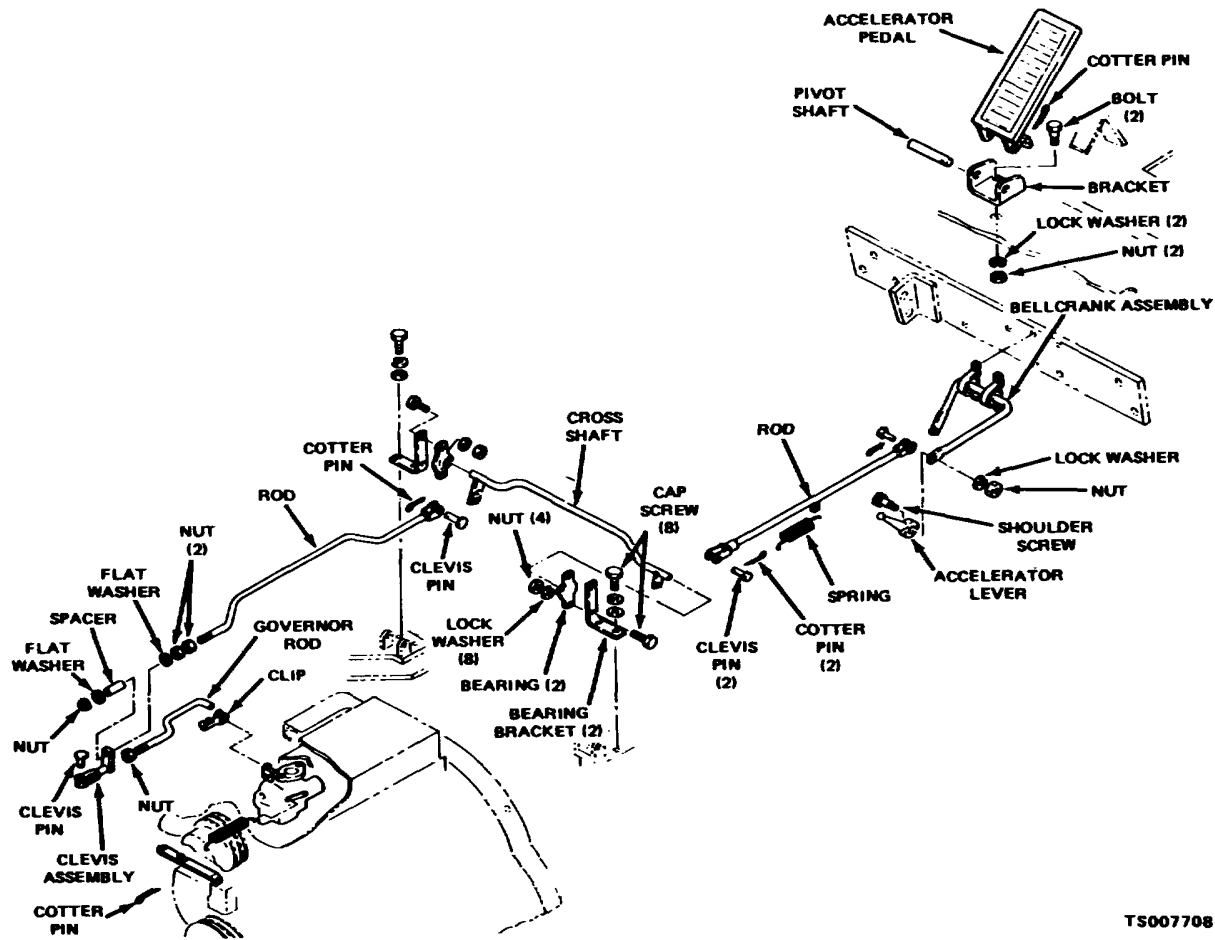

TS007708

Figure 4-35. Accelerator Pedal and Linkage

**WARNING**

Dry cleaning solvent, P-D-680, used to clean parts potentially dangerous to personnel and property. Avoid repeated and prolonged skin contact. Do not use near open flame or excessive heat. Flash point of solvent is 100°F.-138°F. (38°C.-60°C.).

*b. Cleaning and Inspection.*

- (1) Clean all parts except the pedal with dry cleaning solvent P-D-680; dry thoroughly.
- (2) Inspect the accelerator pedal for cracks, worn pedal surface, worn pivot holes, distortion, and other damage. Replace a damaged pedal.
- (3) Inspect the return spring for cracks, distortion, loss of tension, and worn ring ends. Replace a damaged spring.
- (4) Inspect all other parts for cracks, distortion, worn or damaged pivot points, damaged threads, and other damage; replace damaged parts.

*c. Reassembly and Installation.*

Reassemble and install the accelerator pedal and linkage as shown in figure 4-35. Adjust the linkage as follows:

- (1) Adjust the position of the clevis on the governor throttle rod as directed in paragraph 4-49. Make sure the governor arm travels its full length when the accelerator pedal is depressed. Adjust the position of the clevis on the bellcrank, if necessary, and tighten the locknut.
- (2) Adjust the position of the stop bolt under the accelerator pedal so that the bolt stops pedal travel as the governor reaches its limit of travel. This prevents excessive strain on the linkage. Make sure the bolt does not limit the travel of the governor arm.
- (3) Recheck that all adjustment requirements in paragraph 4-49 are met.
- (4) Replace all worn or damaged parts with new parts.

**4-51. Fuel Tank Filler Cap and Screen***a. Inspection.*

(1) Loosen thumbscrew on fuel filler cap. Lift latch arm and pull filler cap and screen assembly from fuel filler well.

(2) Unscrew screen from fuel cap. Hold screen up to a strong light and inspect for damage or

clogged condition.

(3) Screen may be cleaned by directing a blast of compressed air through the screen from inside-out.

(4) Inspect gasket for damage and wear. Replace a worn gasket.

**Section XV. COOLING SYSTEM****4-52. General**

The purpose of the cooling system is to cool the engine, torque converter, and transmission. The system consists of the radiator, thermostat, fan, water pump, and hoses. Engine coolant is circulated by the water pump through the engine to the radiator where it is cooled. The radiator is cooled by the flow of air circulated by the fan. When the engine coolant is below operating temperature, the thermostat closes, preventing the circulation of coolant until it reaches the proper temperature. Torque converter and transmission oil is transferred through hoses to the lower part of the radiator where it is cooled.

**4-53. Radiator***a. Cleaning.*

(1) Clean foreign matter from the cooling fins by forcing compressed air through the radiator from the counterweight toward the engine.

(2) Flush the cooling system with a chemical cleaner in accordance with current directives. After flushing, fill the cooling system with antifreeze solution (table 3-2) containing a rust inhibitor or water and rust inhibitor in accordance with current directives.

(3) If the cooling system is badly clogged with rust and scale, reverse flush the radiator and engine as follows:

(a) Drain the cooling system.

(b) Loosen the clamps (fig. 4-36) and disconnect the upper hose from the radiator and the lower hose from the water pump.

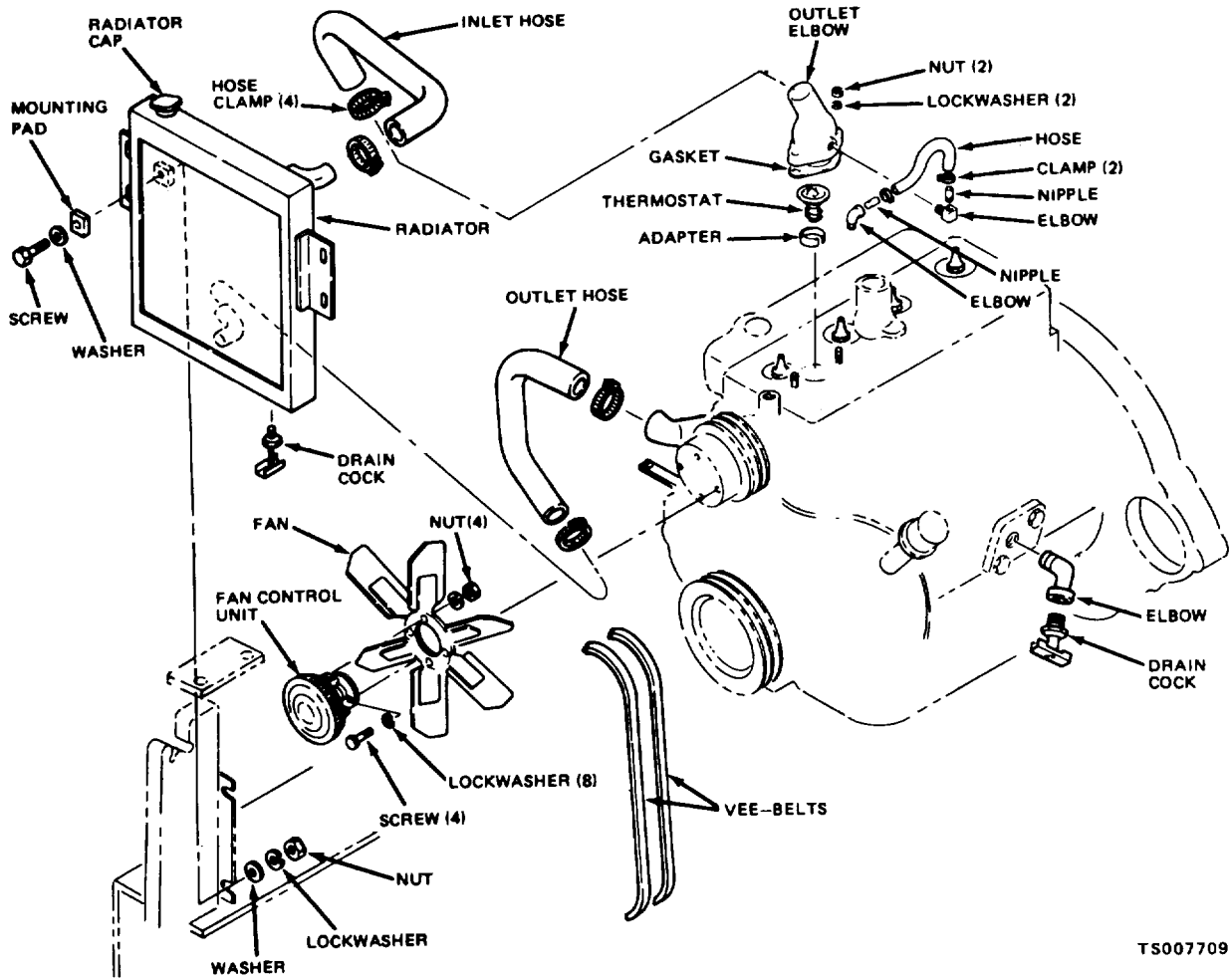

TS007709

Figure 4-36. Cooling System, Disassembly and Reassembly

(c) Connect the flushing gun to the lower hose as shown in figure 4-37. Fill the radiator with water. Shut off the water supply and blow the water out of the radiator with air. Apply air pressure gradually to

prevent damage to the radiator. Repeat this process until the flushing stream runs clear. Disconnect the flushing gun.

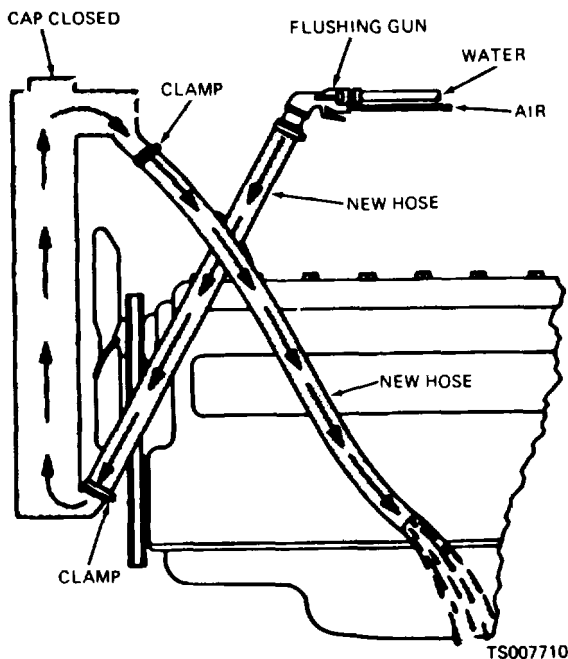

Figure 4-37. Reverse Flushing the Radiator

(d) Remove the bypass hose from the elbow on the thermostat housing and water pump. Install a plug in the elbow on the thermostat housing.

(e) Remove the nuts and lockwashers that secure the thermostat housing to the cylinder head; remove the thermostat housing, thermostat and adapter. Reinstall the thermostat housing; secure the nuts.

(f) Connect the flushing gun to the upper hose on the thermostat housing as shown in figure 4-38. Completely fill the engine water jacket with water. Hold a hand over the water pump outlet to be sure the water jacket is completely full. Shut off the water supply. Blow the water out of the water jacket with air. Repeat this procedure until the flushing stream runs clean. Disconnect the flushing gun.

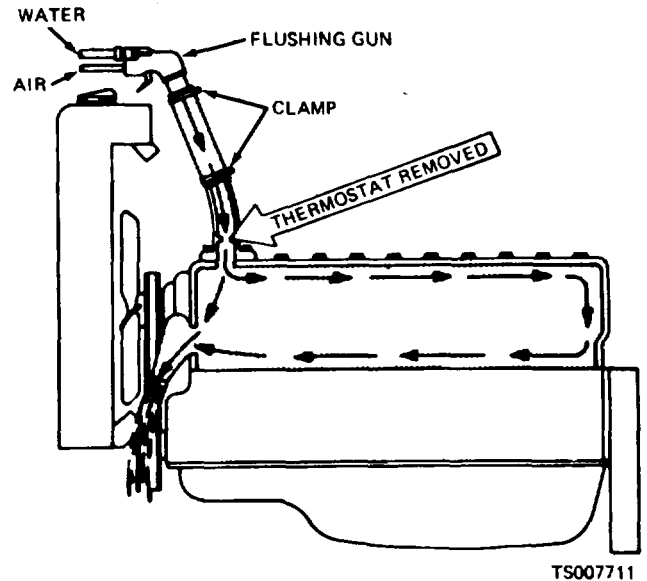

Figure 4-38. Reverse Flushing the Engine Block

(g) Install the thermostat in the thermostat housing; install the bypass hose; install the upper and lower hoses on the radiator and water pump; secure with clamps. Close the engine and radiator drain cocks. In accordance with current directives, fill the cooling system with antifreeze (table 3-2) containing a rust inhibitor or water and rust inhibitor.

*b. Removal.*

- (1) Remove the overhead guard (para 4-16) and radiator cover.
- (2) Drain the radiator by opening the drain cock and removing the radiator cap.
- (3) Disconnect the transmission cooling lines from the radiator (para 4-82).
- (4) Remove the radiator and associated parts as shown in figure 4-36.

*c. Inspection, and Testing.*

- (1) Inspect the radiator for cracks, leaks, clogged tubes, dents, and signs of leaking. Carefully inspect the solder joints between the tank and core.



(2) If the condition of the radiator is uncertain, test it for leaks as follows:

(a) Plug all outlets except the top outlet. Immerse the radiator in water and apply low pressure air (10 PSIG maximum) through the top outlet.

(b) Carefully check for air bubbles which indicate a leak.

**NOTE**

Make sure the radiator is empty of water before performing an air check. Water in radiator may prevent the air from being ejected through a leaking area.

(c) Replace the radiator if it leaks.

*d. Installation.*

(1) Install the radiator as shown in figure 4-36.

(2) Close the drain cock at the bottom of the radiator and fill the radiator in accordance with current directives. Use antifreeze, if necessary (table 3-2), or use water containing a rust inhibitor.

(3) Run the engine until it reaches operating temperature and check for leaks. Operate the fork lift truck in forward and reverse directions and check the transmission oil level. Add oil if necessary.

(4) Install the overhead guard and radiator cover.

**4-54. Thermostat**

*a. Removal.*

(1) Drain the cooling system.

(2) Loosen the clamp and disconnect the upper hose from the thermostat housing. Remove the bypass hose from the elbow on the thermostat housing; remove the elbow and thermostat (fig. 4-36).

*b. Inspection and Testing.*

(1) Inspect the thermostat and thermostat housing for cracks, distortion, scale or dirt deposits, or other physical damage.

(2) Suspend the thermostat in a pan of water on a stove. Place a thermometer capable of reading temperatures up to the boiling point in the pan. Heat the water. The thermostat must open between 150° to 185 °F.

(3) Replace the gasket and, if defective, replace the thermostat.

*c. Installation.*

(1) Install the thermostat housing as shown in figure 4-36.

(2) Install the upper hose and the bypass hose.

**4-55. Fan and Alternator Belts**

*a. Adjustment.* The fan and alternator belts must be tightened so that they can be deflected between 3/4 and 1 inch at a point midway between the crankshaft pulley and the fan drive pulley. If necessary, adjust the belts as shown in figure 4-39.

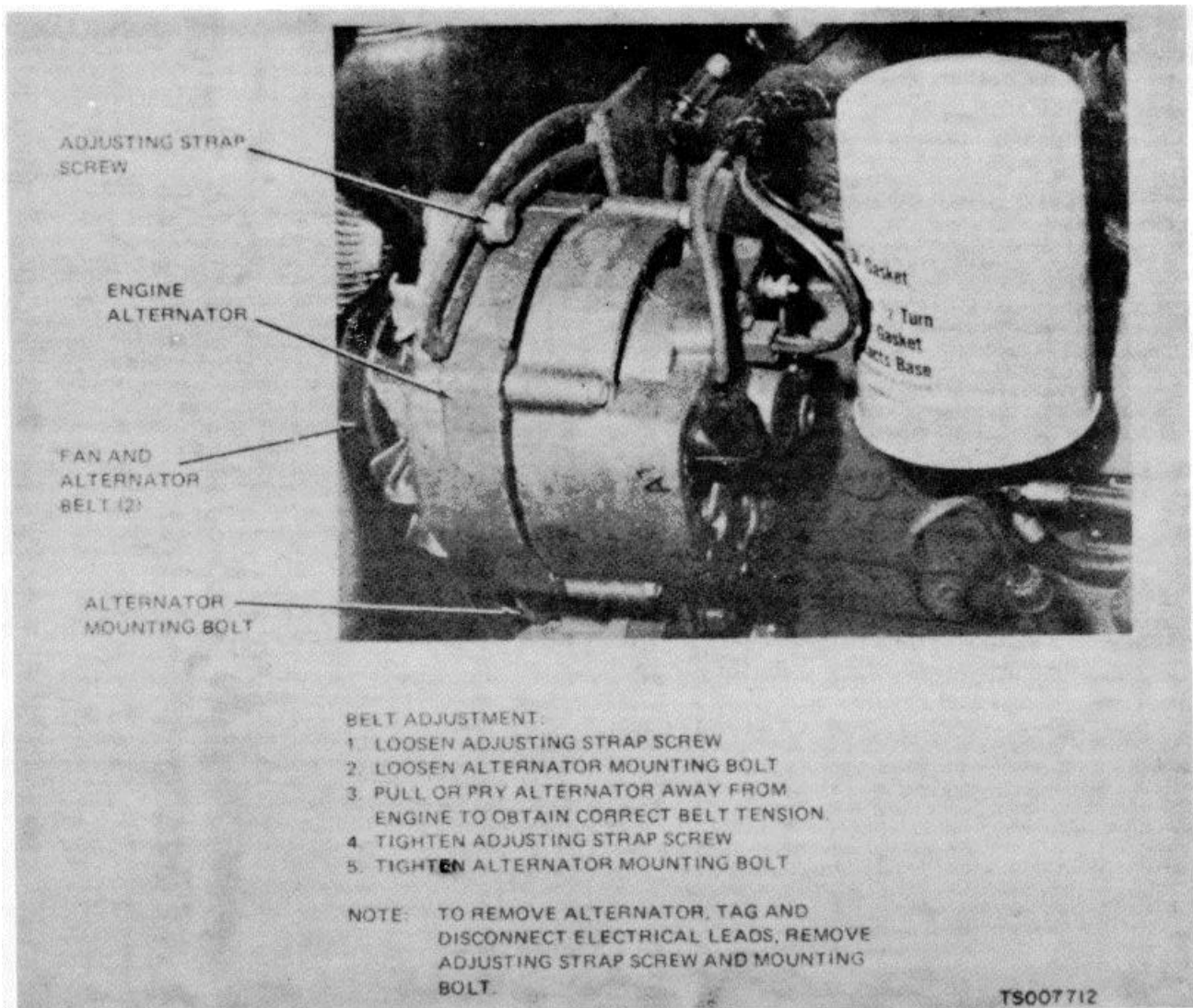

Figure 4-39. Fan and Alternator Belt Adjustment and Replacement, and Alternator Replacement

*b. Replacement.* If fan and alternator belts are worn, cracked or frayed, replace them as a matched set. Do not replace the belts singly, since this will result in excessive wear and premature failure of the new belt. Replace as follows:

(1) Loosen the adjusting strap screw (fig. 4-39) that secures the adjusting strap to the alternator. Push the alternator toward the engine to relieve all belt tension.

(2) Slip the belts from the pulleys and over the fan to remove them.

(3) Slip the new belts over the cooling fan

blade and seat them in the crankshaft pulley, alternator drive pulley, and fan pulley.

(4) Tighten and adjust the fan belts as directed in subparagraph a above.

#### 4-56. Water Pump and Fan Blade

##### *a. Removal and Disassembly.*

(1) Remove the fan and alternator belts (para 4-55).

(2) Remove the fan blade and water pump as shown in figure 4-40.

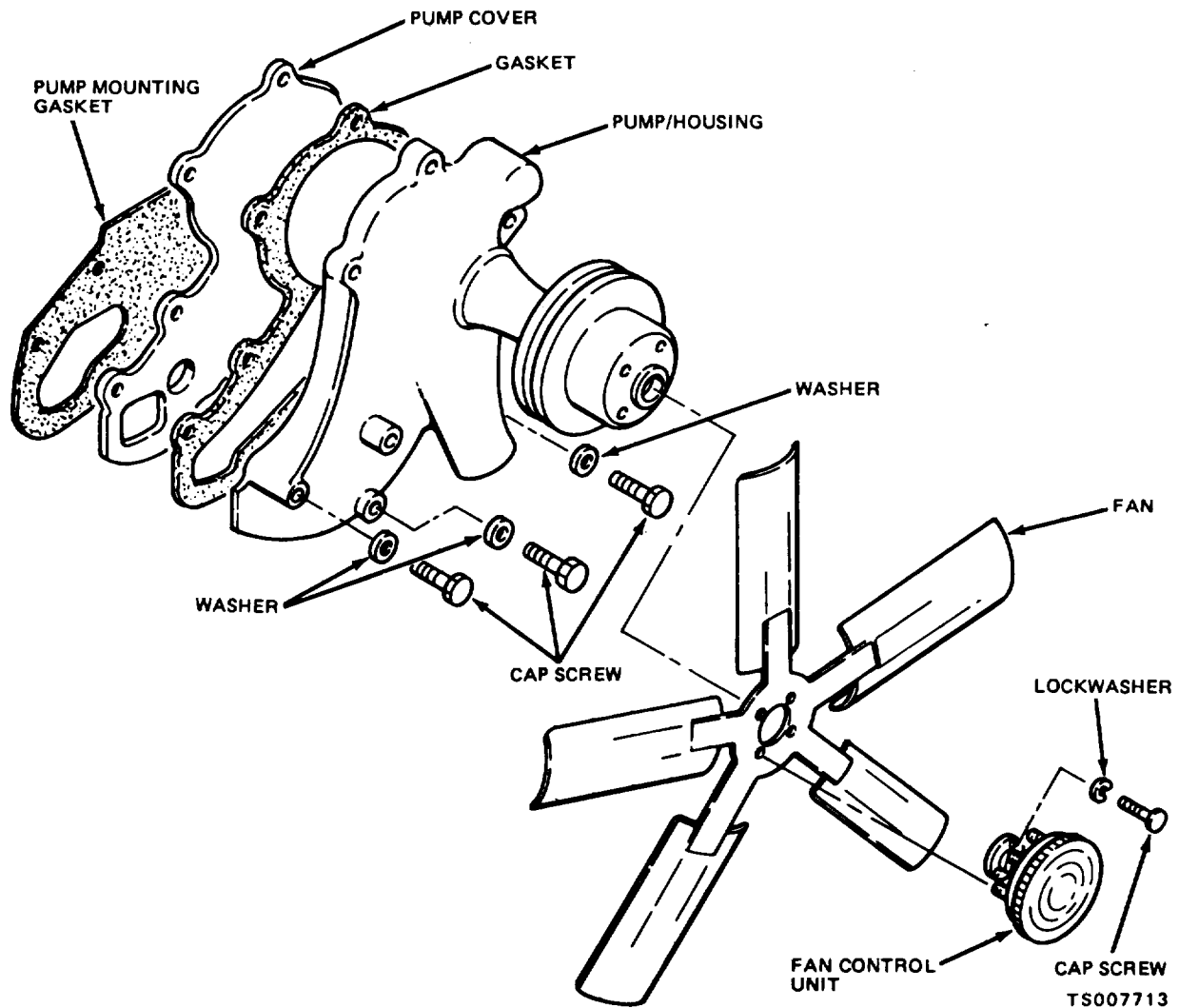

Figure 4-40. Water Pump and Fan Blade, Removal and Installation

**WARNING**

Dry cleaning solvent, P-D480, used to clean parts is potentially dangerous to personnel and property. Avoid repeated and prolonged skin contact. Do not use near open flame or excessive heat. Flash point of solvent is 100°F.-138°F. (38°C.-60°C.).

*b. Cleaning and Inspection.*

(1) Discard and replace the gasket. Clean the parts with a cloth dampened with dry cleaning solvent P-D-680; dry thoroughly.

(2) Inspect the water pump for cracks, signs of leaking, and other damage. Turn the pump

shaft. It must rotate freely, without catching or binding. Replace a damaged water pump.

(3) Inspect the fan blade for cracks, distortion, loose fan elements, and other damage; replace a damaged fan blade.

*c. Reassembly and Installation.*

(1) Reassemble and install the water pump and fan blade as shown in figure 4-40. Use a new gasket at installation. Torque cap screws to 25 to 30 foot-pounds torque.

(2) Install and adjust the fan and generator drive belts (para 4-55).

## Section XVI EXHAUST SYSTEM

**4-57. General**

The exhaust system conducts the exhaust gases from the engine through an exhaust pipe, muffler, and tailpipe, and then discharges them to the atmosphere. Since the muffler and tailpipe are mounted behind the radiator, the engine cooling fan helps to circulate the gases away from the truck. The exhaust muffler dampens the exhaust noises by directing the flow through a series of internally installed baffles. The exhaust muffler is mounted inside the counterweight which is mounted on the back of the truck to counterbalance loads placed on the truck forks.

**4-58. Exhaust Muffler and Piping***a. Removal and Disassembly.*

(1) Support the weight of the counterweight with a hoist and remove the bolts that secure the counterweight to the truck. Lift up and pull out on the counterweight to remove it.

(2) Remove and disassemble the exhaust pipe, muffler, and tailpipe as shown in figure 4-41.

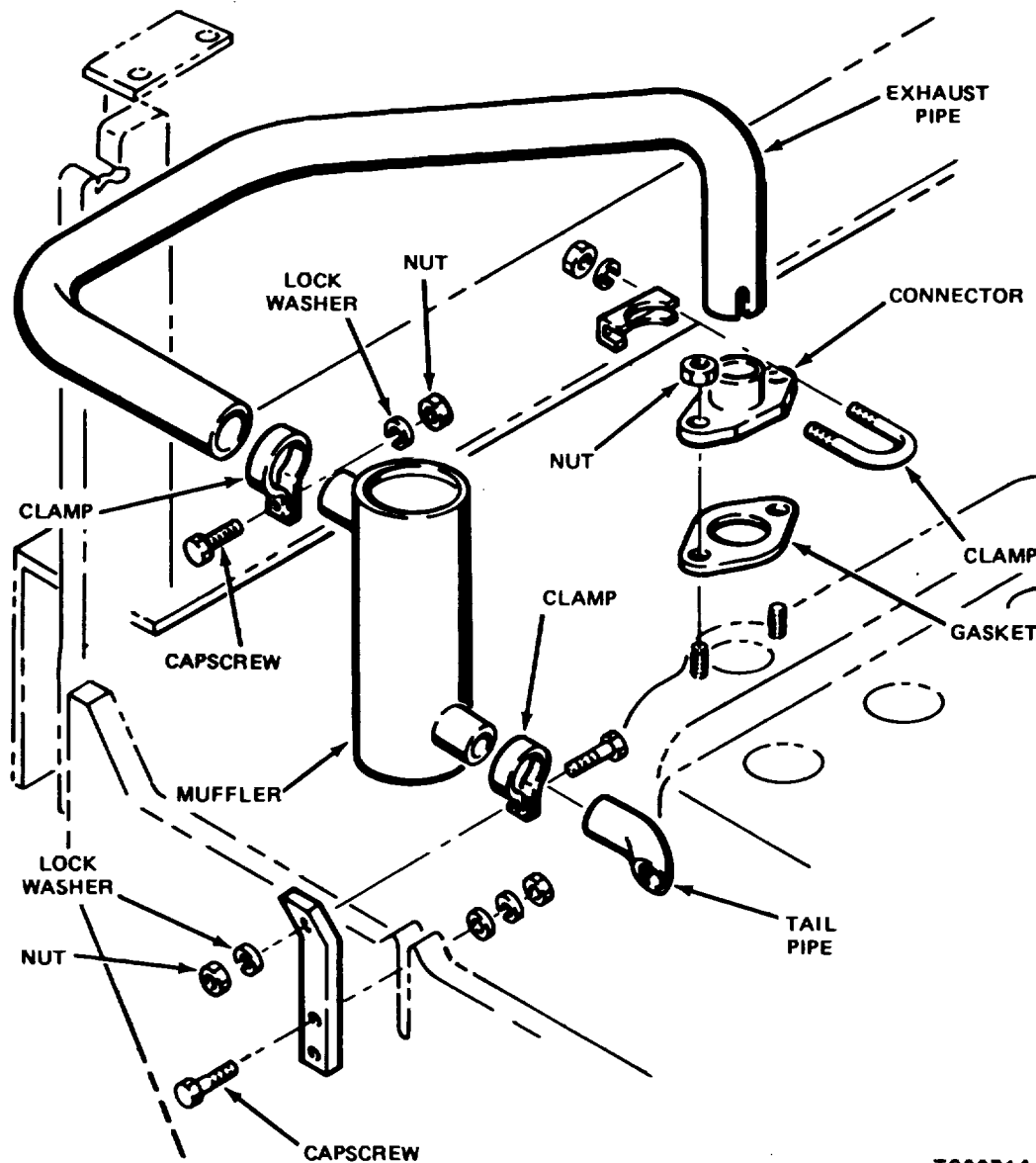

TS00714

Figure 4-41. Exhaust System, Removal and Installation

**WARNING**

Dry cleaning solvent, P-D-680, used to clean parts is potentially dangerous to personnel and property. Avoid repeated and prolonged skin contact. Do not use near open flame or excessive heat. Flash point of solvent is 100°F.-138°F. (38°C.-60°C.).

*b. Cleaning and Inspection.*

(1) Clean the exhaust pipe, muffler, and tailpipe with a wire brush. If necessary, remove gummy deposits with dry cleaning solvent P-D-680. Clean all other parts with dry cleaning solvent P-D-680.

(2) Inspect the muffler, exhaust pipe, and tailpipe for holes, dents, cracks, thin spots, and other damage; replace damaged parts.

(3) Inspect all remaining parts for cracks, distortion, damaged threads, and other damage; replace damaged parts.

*c. Reassembly and Installation.*

(1) Install the exhaust system parts as shown in figure 4-41. Start engine and listen for leaks around clamps and joint.

(2) Using a hoist, place the counterweight on the rear of the truck. Install bolt and tighten securely.

**Section XVII. STEERING SYSTEM****4-59. General**

The fork lift truck is steered by the rear wheels. Steering is done by a steering handwheel through the steering gear and a drag link which is mechanically connected to the steering gear pitman arm and the steering axle spider. The spider is connected to the rear

steering knuckles by tie rods. The tie rods maintain the correct steering relationship between the wheels.

**4-60. Drag Link**

*a Removal and Disassembly.* Remove and disassemble the drag link as shown in figure 4-42.

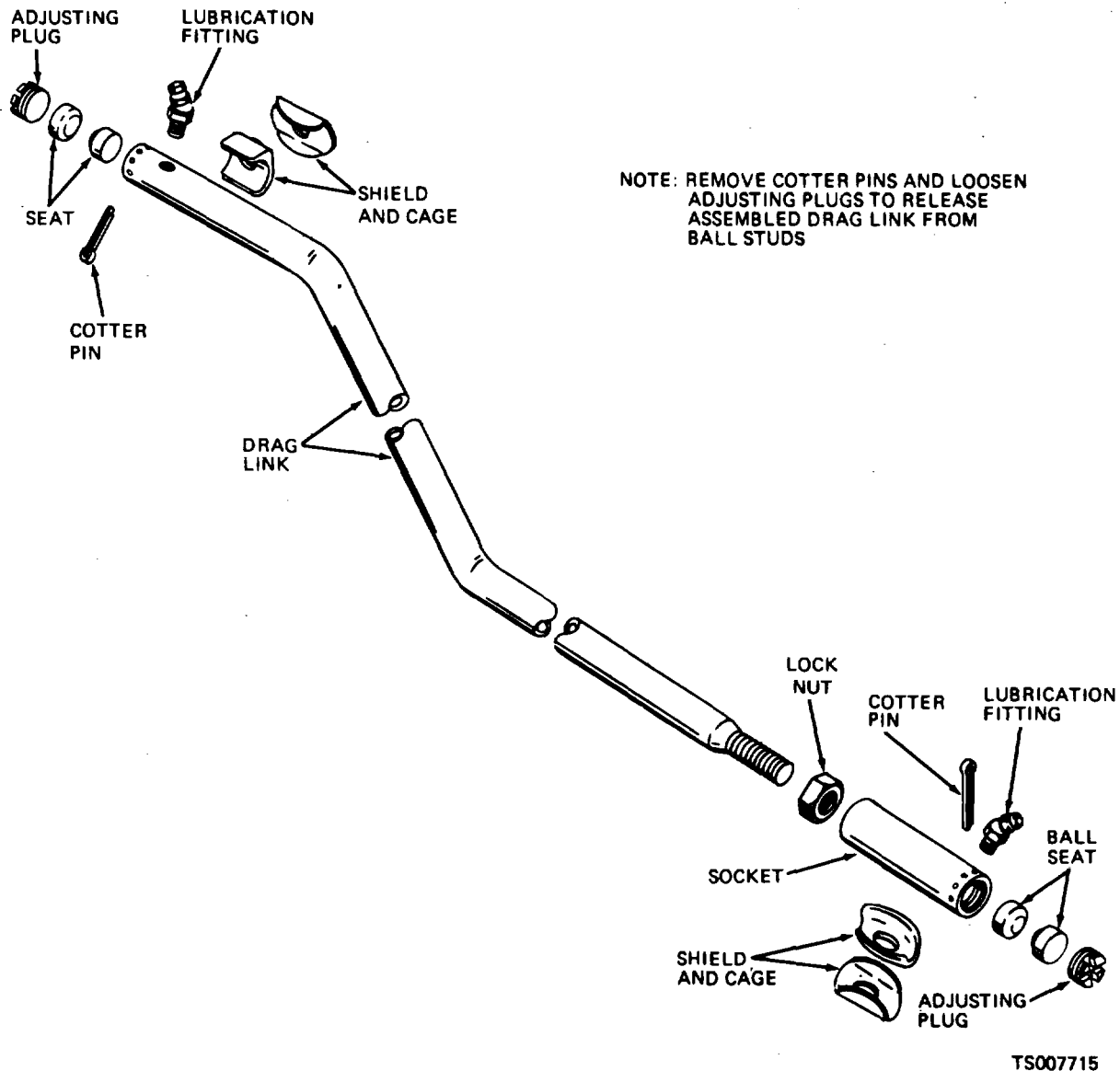

Figure 4-42. Drag Link, Disassembly and Reassembly

**WARNING**

Dry cleaning solvent, P-D-680, used to clean parts is potentially dangerous to personnel and property. Avoid repeated and prolonged skin contact. Do not use near open flame or excessive heat. Flash point of solvent is 100°F.-138°F. (38°C.-60°C.).

*b. Cleaning and Inspection.*

- (1) Clean the metallic parts of the drag link with dry cleaning solvent P-D-680.
- (2) Inspect the ball seats for cracks, wear or scoring of the seating surfaces, and other damage; replace damaged parts.

(3) Inspect the drag link and socket for cracks, distortion, damaged threads, and severe dents; replace if damaged.

(4) Inspect all other parts for cracks, distortion, damaged threads, and other damage; replace damaged parts.

*c. Reassembly, Installation, and Adjustment.*

(1) Lubricate the seating surfaces of the ball seats with grease of the type indicated in the lubrication chart, prior to assembly.

(2) Turn steering handwheel to full right turn position. Turn handwheel back 1/4 turn minimum.

(3) Install assembled drag link with steering

axle against right turn stop. Adjust the length of the drag link by rotating the socket on the adjustable end of the drag link so that the drag link can be installed without moving either the wheel setting or the steering gear setting. Insure that one ball seat is placed on each side of the ball stud.

(4) When installing the adjusting plugs, do not overtighten, since this will cause binding between the ball seats and the ball studs. Tighten the adjusting plugs only to 20 foot-pounds, then back off to nearest cotter pin hole. Install cotter pins.

(5) Use a grease gun and lubricate the drag link sockets as outlined in the lubrication order.

(6) Check the steering mechanism after lubricating to insure that it operates freely without binding.

#### **4-61. Tie Rods**

Paragraph 4-61.a through c. (1) deleted.

Figure 4-43 deleted.

(2) To adjust the tie rods, raise the steering wheels from the floor. Disconnect the drag link.

(3) Place the wheels in a straight-ahead position, so that they will track with the drive wheels. Install the tie rods between the steering knuckles and the steer axle spider.

(4) Adjust the tie rods so that both rods are exactly the same length and both steer wheels are tracking straight ahead, without toe-in or toe-out. To adjust the tie rod length, rotate the tie rod in the required direction. The tie rod ends have one right-hand thread and one left-hand thread so that rotation of the rod in one direction will lengthen the rod while rotation in the opposite direction will shorten the rod.

(5) After the correct adjustment is achieved, tighten the lock-nuts against the tie rod to prevent the tie rod ends from turning.

(6) Adjust and install the drag link as directed in paragraph 4.60.

**Change 2 4-59**

## Section XVIII. MAINTENANCE OF ENGINE

**4-62. General**

The fork lift truck is powered by a four-cylinder, internal combustion, water-cooled, L-head, gasoline engine. A combustible mixture of fuel and air is delivered by the carburetor through the manifold and intake valves to the combustion chambers, where it is ignited by an electrical spark across the electrodes of the spark plugs. The burning mixture of fuel and air causes a heat rise in the combustion chamber. This heat rise causes an expansion of the gasses in the combustion chamber that forces the pistons downward in the cylinders. The motion of the pistons causes rotation of the crankshaft. The burned mixture and hot gasses are passed through the exhaust valves to the exhaust manifold. Heat left in the engine is transferred to the radiator by the coolant in the cooling system. The exhaust and intake valves are operated by the camshaft which is geared to the crankshaft. Moving parts of the engine are pressure-lubricated by an oil pump driven off the camshaft.

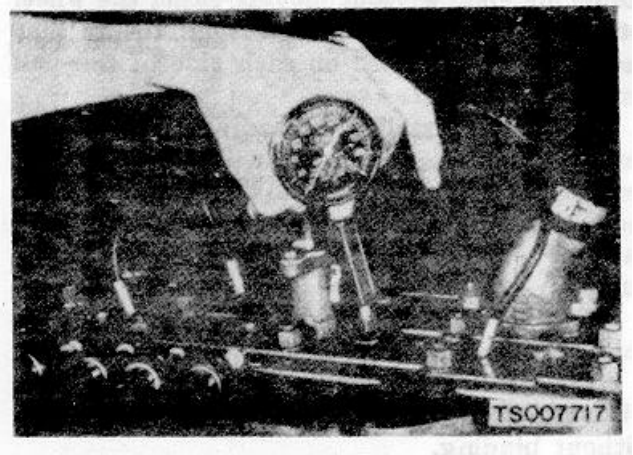

Figure 4-44. Checking Engine Compression

**4-63. Testing***a. Compression Test.*

(1) Test the battery (para 4-37). If the battery is not fully charged, replace it with a fully charged battery.

(2) Start the engine and allow it to run until it reaches operating temperature (160--180°F), then shut off the engine.

(3) Clean around the spark plug ports with compressed air and a cloth dampened in an approved cleaning solvent. Remove the spark plugs.

(4) Hold a compression gage in a spark plug port as shown in figure 4-44. Crank the engine with the starting motor until the highest gage reading is reached. Record the reading. Repeat this process at each of the remaining spark plug ports. The firing order is 1-3-4-2. Reinstall spark plug.

(5) Compression readings above 110 PSI, and within 10 PSI of each other are normal. If readings are below 110 PSI or are irregular, the valves or valve seats are burned, the piston rings are worn, or there are other internal engine problems.

(6) If compression fails to fall within the required range, report to direct or general support maintenance personnel.

**4-64. Engine Adjustment**

Engine adjustments are restricted to engine timing, valve lash, carburetor and governor adjustments. Procedures for these adjustments are outlined in the applicable sections below.

*a. Ignition Timing Test and Adjustment.*

(1) Set distributor point contact gap (para 4-34).

(2) Remove spark plug No. 1 nearest the radiator. Place a finger or thumb over the spark plug port. Crank the engine with the starting motor until air is forced out of the no. 1 cylinder past the thumb or finger plugging the port. The firing order is 1-3-4-2.



(3) Hold a light in a position to light the timing hole on the flywheel housing. Crank the engine until the dead center mark on the flywheel lines up with the pointer in the timing hole.

(4) Remove the distributor cap, rotor, and dust cover. With the timing hole pointer on the flywheel dead center mark, the contact points in the distributor should just start to open to fire the No. 1 cylinder.

(5) If the contact points are not just beginning to open, loosen the distributor clamp arm (fig. 4-21) and rotate distributor to just open the points.

**WARNING**

Dry cleaning solvent P-D-680 is toxic and flammable. Wear protective goggles and gloves and use only in a well ventilated area. Avoid contact with skin, eyes, and clothes and don't breath vapors. Do not use near open flame or excessive heat. The flash point is 100°F - 138°F. (38°C - 59°C). If you become dizzy while using cleaning solvent, get fresh air immediately and get medical aid. If contact with eyes is made, wash your eyes with water and get medical aid immediately.

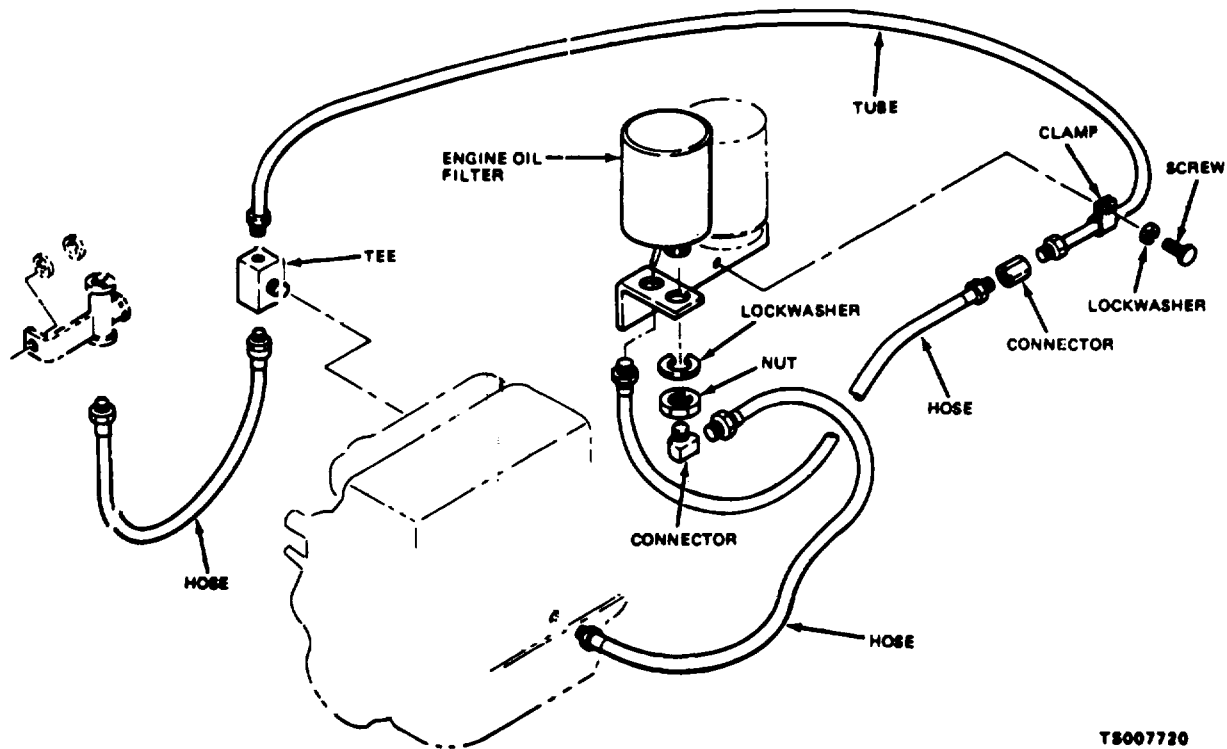

Figure 4-47. Engine Oil Filter, Removal and Installation

(6) To determine exactly when the points open or close, connect a test light between the distributor primary terminal and ground. The light will be off when the points are closed and will go on when the points open.

(7) Replace the timing hole cover and the distributor dust cover, rotor, and spark plug.

Paragraphs 4-65 and 4-66 deleted.

Figures 4-45 and 4-46 deleted.

**4-67. Engine Oil Filter**

a. *Service.* Service the engine oil filter as described in paragraph 4-8. Filter service shall coincide with engine oil change.

b. *Removal.*

(1) Remove the oil filter and associated parts as shown in figure 4-47.

(2) Flush the hoses with a cleaning solvent which will not attack rubber. Clean all remaining parts with dry cleaning solvent P-D-680.

*c. Installation.*

(1) Install the oil filter and related parts as shown in figure 4-47. Use a new filter element during reassembly.

**4-68. Intake and Exhaust Manifold**

*a. Removal.*

(1) Remove the carburetor (para 4-42) and disconnect the air inlet hose from the air cleaner (fig. 4-32).

(2) Disconnect the exhaust connector from the manifold (fig. 4-41).

(3) Disconnect the positive crankcase ventilation piping from the intake and exhaust manifold (para 4-47).

(4) Refer to figure 4-48 and remove the intake and exhaust manifold from the engine.

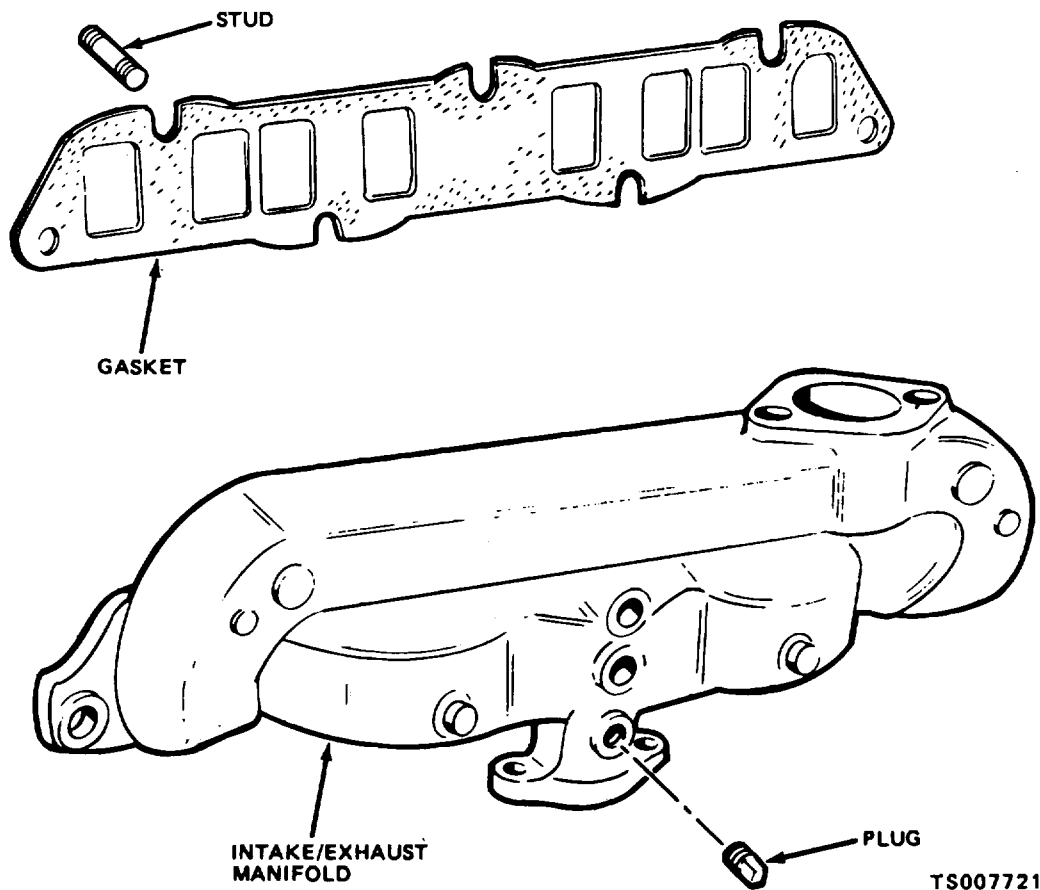

Figure 4-48. Intake and Exhaust Manifold, Removal and Installation

**WARNING**

Dry cleaning solvent, P-D-680, used to clean parts is potentially dangerous to personnel and property. Avoid repeated and prolonged skin contact. Do not use near open flame or excessive heat. Flash point of solvent is 100°F.-138°F. (38°C.-60°C.).

*b. Cleaning and Inspection.*

(1) Clean dirt from the manifold with a wire brush; then clean with a cloth dampened in dry cleaning solvent P-D-680.

(2) Inspect the manifold for cracks, warping, damaged sealing surfaces, corroded areas, damaged threads, or other defects.

(3) Inspect for loose or damaged studs.  
 (4) Replace the gasket; replace other parts if defective.

*c. Installation.*

(1) Refer to figure 4-48 and install the intake manifold, using a new gasket. Tighten the stud nuts to 25 to 30 foot-pounds.

(2) Install the positive crankcase ventilation piping on the manifold (para 4-47).

(3) Install the carburetor (para 4-42). Connect the air inlet hose to the air cleaner (fig. 4-32).

(4) Connect the exhaust connector to the manifold (fig. 4-41).

## Section XIX. WHEELS AND TIRES

### 4-69. General

The fork lift truck is steered by the rear wheels and driven by the front wheels. The rear wheel hubs are mounted on the steering knuckle of the steer axle. The front wheel hubs are mounted on the spindle of the drive axle. The front wheels are driven by a ring gear and pinion system which provides the final speed reduction at the wheels. All wheel hubs ride on tapered roller bearings which must be cleaned and repacked with grease at the intervals indicated on the lubrication chart. The tires are solid rubber cushion type.

### 4-70. Wheels and Tires

#### a. Removal.

(1) To raise the front end of the truck for wheel and tire replacement, tilt the upright back as far as possible and install a wooden block under the bottom of the uprights. Tilt the upright forward to raise the front end of the truck. To raise the rear wheels for wheel and tire replacement, use a jack or hoist. Place blocking under the frame.

(2) Remove the bolts that secure the wheel and tire assembly to the wheel hub and remove the wheel and tire as shown in figure 4-49.

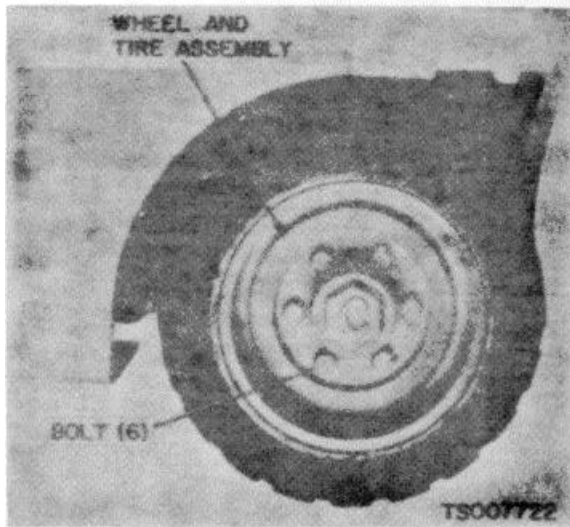

Figure 4-49. Wheel and Tire, Removal and Installation

### WARNING

Dry cleaning solvent, P-D-680, used to clean parts is potentially dangerous to personnel and property. Avoid repeated and prolonged skin contact. Do not use near open flame or excessive heat. Flash point of solvent is 100°F.-138 ° F. (38°C.-60°C.).

#### b. Cleaning and Inspection.

(1) Clean the wheels and tires with water. Remove greasy and gummy deposits with dry cleaning solvent P-D-680.

(2) Inspect the wheels for distortion, cracks, elongated or worn mounting holes, and other damage.

(3) Inspect the tires for cuts, imbedded glass or metal, wear, deterioration caused by oil, grease, or chemicals, and other damage. Remove imbedded particles. Use a sharp knife to trim around cuts, removing the edges which could catch and cause further enlargement of the damaged area.

(4) If either the wheel or tire is damaged, replace the parts as an assembly.

c. *Installation.* Install the wheel and tire assembly on the hub as shown in figure 4-49. Torque front wheel bolts to 80-90 foot-pounds and torque rear wheel bolts to 115-125 foot-pounds.

### 4-71. Wheel Bearings

#### a. Removal and Disassembly.

(1) To raise the front end of the truck, tilt the upright back as far as possible and install a wooden block under the uprights. Tilt the upright forward to raise the front wheels from the ground. To raise the rear wheels, use a jack or hoist. Place blocking under the frame.

(2) Refer to figure 4-50 to remove the wheel bearings from the spindle of the front axle or from the steering knuckle of the rear axle.

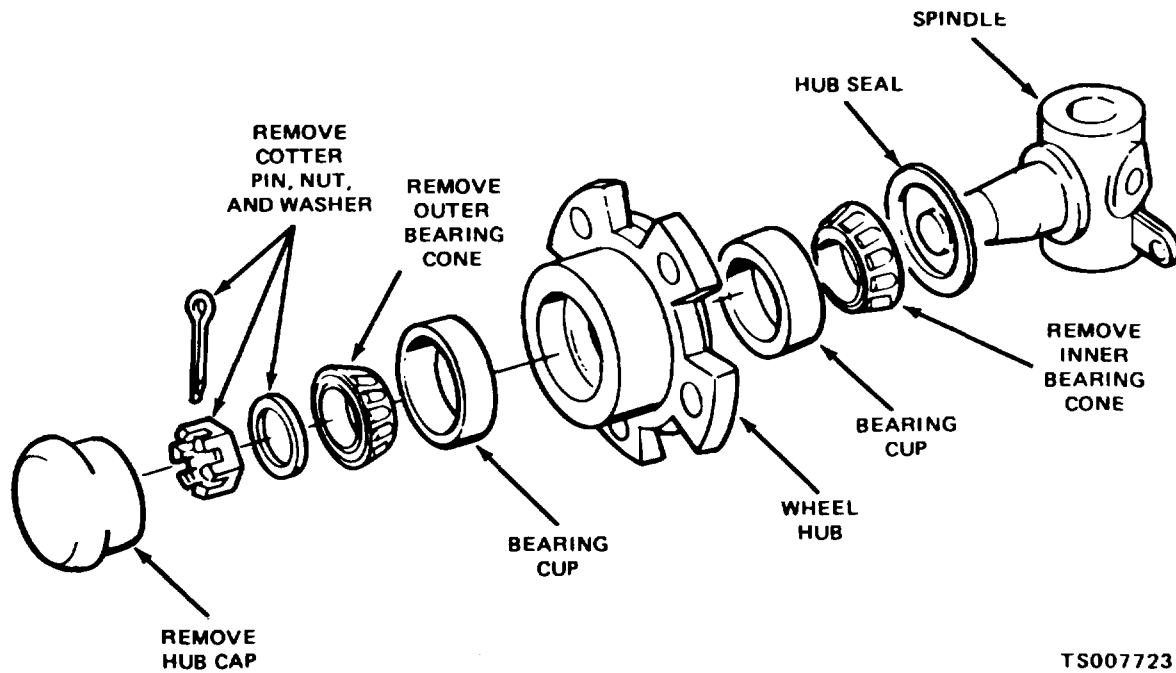

Figure 4-50. Wheel Bearings and Hub, Disassembly and Reassembly

**WARNING**

Dry cleaning solvent, P-D-680, used to clean parts is potentially dangerous to personnel and property. Avoid repeated and prolonged skin contact. Do not use near open flame or excessive heat. Flash point of solvent is 100°F. -138°F. (38°C. -60°C.).

*b. Cleaning and Inspection.*

(1) Clean the bearing cones by flushing up and down in dry cleaning solvent P-D-680. If necessary, tap the large side of the bearing against a soft wooden block to dislodge solidified grease. Dry bearings with clean, dry compressed air. Direct the stream of air at the bearing so that the rollers and cage will not spin. Dip bearings in light oil immediately after cleaning.

(2) Clean the hub the spindle with a cloth dampened with dry cleaning solvent P-D-680.

(3) For the drive wheels, clean the ring gear and pinion as directed in paragraph 4-79.

(4) Inspect the bearing cones for pitting, scoring, wear, and cracked cages, and for rough or binding operation. Replace damaged bearings.

(5) Inspect the bearing cups for scoring, scratches, nicks, and other damage. If damaged, drive the cups from the wheel hub using a soft drift. Press in new bearing cups, taking care not to damage the cups or hub.

*c. Packing Bearings.* Pack the bearing cones and the interior of the hub with the lubricant recommended by the lubrication order. Take care to prevent dirt or grit from contaminating the grease. During reassembly, pack the ring gear of the drive wheels with grease as directed in paragraph 4-79c.

*d. Reassembly.*

(1) Reassemble the bearings and hub on the spindle or steering knuckle as shown in figure 4-50.

(2) When installing the slotted nut, tighten the nut while rotating the wheel in both directions until the bearings bind slightly during rotation. Back off the nut by 1/6 to 1/4 turn and lock the position of the nut with a cotter pin.

(3) Remove the blocking and lower the truck to the ground.

**Section XX. BRAKES**

**4-72. General**

The service brakes are mounted on the front axle ends. The brake drum rotates with the wheels and the brake

drum assemblies are secured to the spindle supports. The brakes are hydraulically operated by the brake master cylinder, which is

mechanically linked to the brake pedal. The hand brake operates on the transmission shaft. The hand brake V-pulley drum rotates with a transmission pinion shaft. The stationary hand brake V-brake shoe is connected by mechanical linkage to the hand brake lever so that, when the brake is applied, the V-shoe is forced into the V-pulley drum.

**4-73. Hand Brake Shoe and Lever Adjustment**

*a. Shoe Adjustment.* When properly adjusted, the parking brake must be capable of holding the truck on a 15-percent grade with a full, rated load. Adjust the hand brake shoe as follows:

(1) Loosen the locknut (figure 4-51) several turns.

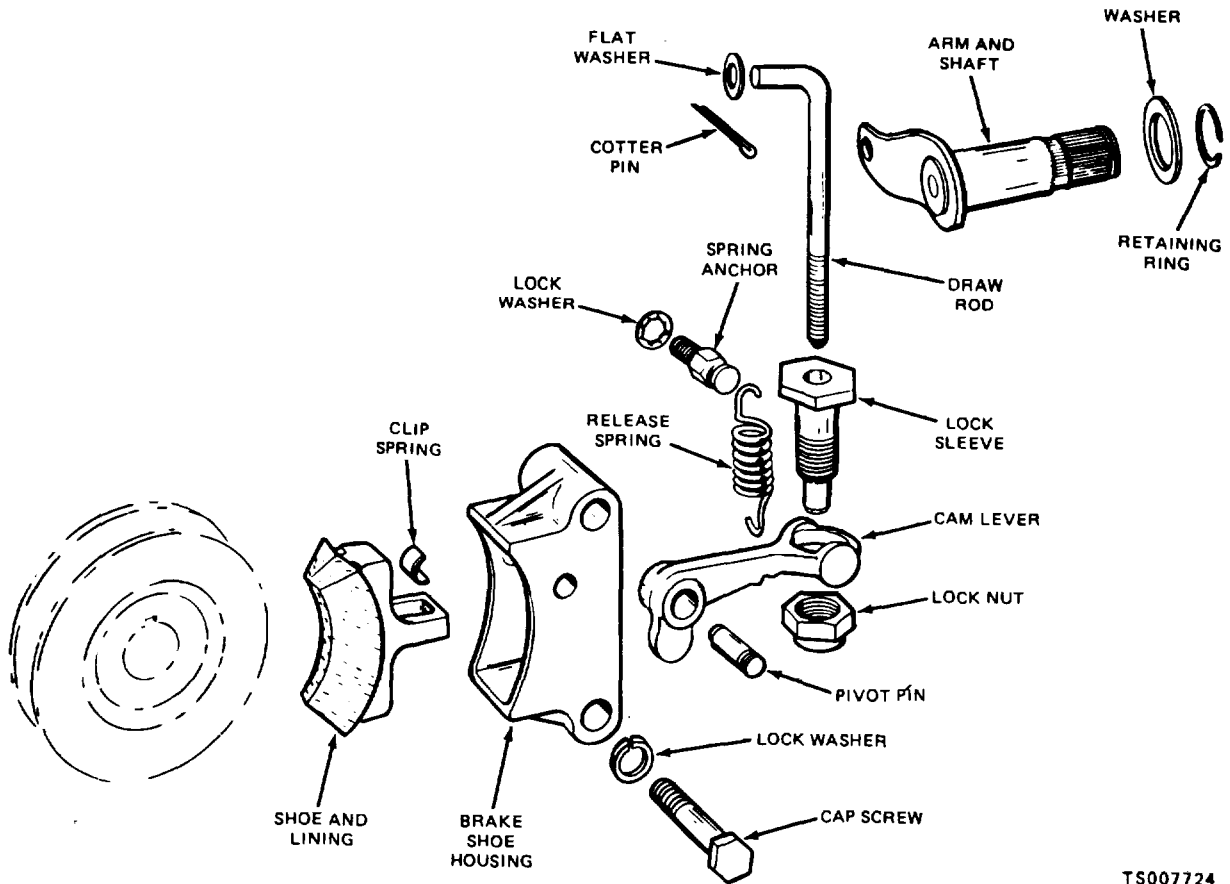

TS007724

Figure 4-51. Parking Brake Adjustment Points

(2) Rotate the lock sleeve counterclockwise to close gap between brake shoe and brake drum.

(3) Hold the lock sleeve and tighten the locknut until snug against cam lever, then back off locknut one-half to three-quarters of a turn.

*b. Lever Adjustment.* Adjustment to the hand brake lever is made by placing the lever in the full forward (released) position, then turning the knurled

knob on the end of the lever several turns clockwise. After making this adjustment, recheck brake action. If necessary, repeat procedure.

**4-74. Hand Brake Lever Replacement**

*a. Removal.* Refer to figure 4-52 and remove the complete hand brake lever assembly.

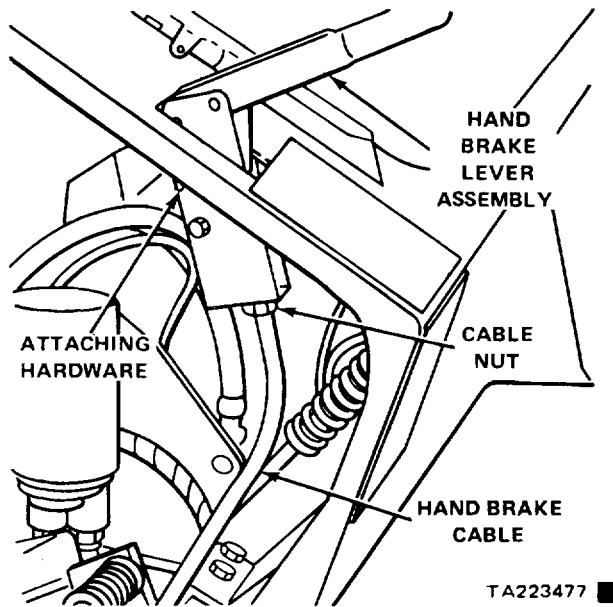

Figure 4-52. Hand Brake Lever, Removal and Installation

b. *Installation.* Installation may be accomplished by reversing the procedures outlined in figure 4-62.

#### 4-76. Service Brakes

Paragraph 4-75.a through c. (3) deleted.

Figure 4-53 deleted.

d. *Bleeding Brake System.* Whenever the brake system is opened for any reason, such as repairs to master cylinder, wheel cylinder, valves or tubing, air will enter the brake system and must be expelled through the bleeding procedure outlined in the following paragraphs. Pressure bleeding, as outlined in paragraph (1) is the preferred method if the proper equipment is available.

(1) *Pressure Bleeding.* Make certain that the pressure bleeding equipment will hold enough of the right type of brake fluid to do the job (about 2 quarts). Do not intermix different types of brake fluid, and never reuse fluid that has been drained from the brake system.

#### **WARNING**

Make certain that pressure bleeder tank is certified for use at pressures exceeding 30 PSI before using.

(a) Clean all dirt, grease, etc., from around the master cylinder reservoir cap on both the brake and inching master cylinder.

(b) Remove the master cylinder reservoir cap and fill reservoir with SAE 70 R3 Heavy Duty Hydraulic Brake Fluid to within 1/4 inch from the top of the reservoir.

(c) Fill the pressure bleeder reservoir with about 2 quarts of the same fluid, and pressurize the tank to NOT MORE than 30 PSI.

(d) Place a flat pan under the axle adapter to catch brake fluid spillage, and connect the pressure bleeder line to the brake master cylinder. Open the pressure bleeder valve.

(e) With the bleeder hook-up completed as shown in figure 4-54, open bleed points B and C and allow fluid to flow from loosened fittings until no further bubbles appear in the flow. Tighten fittings securely when all air is expelled.

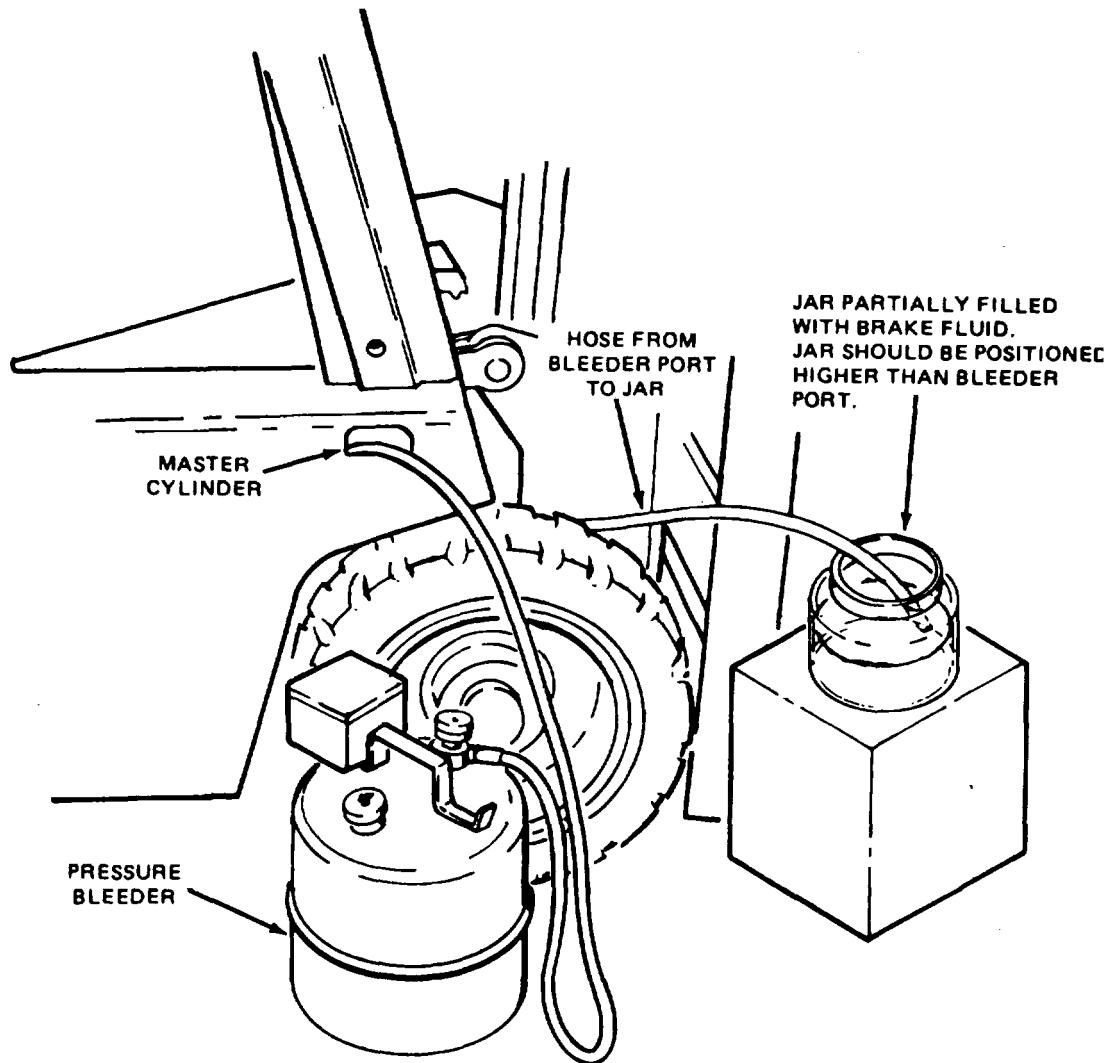

NOTE: BLEED INCHING  
MASTER CYLINDER FIRST

TS007727

Figure 4-54. Pressure Bleeding Setup

(f) Refer to figure 4-55 for identification of the various bleed points within the brake system.

Change 2 4-70

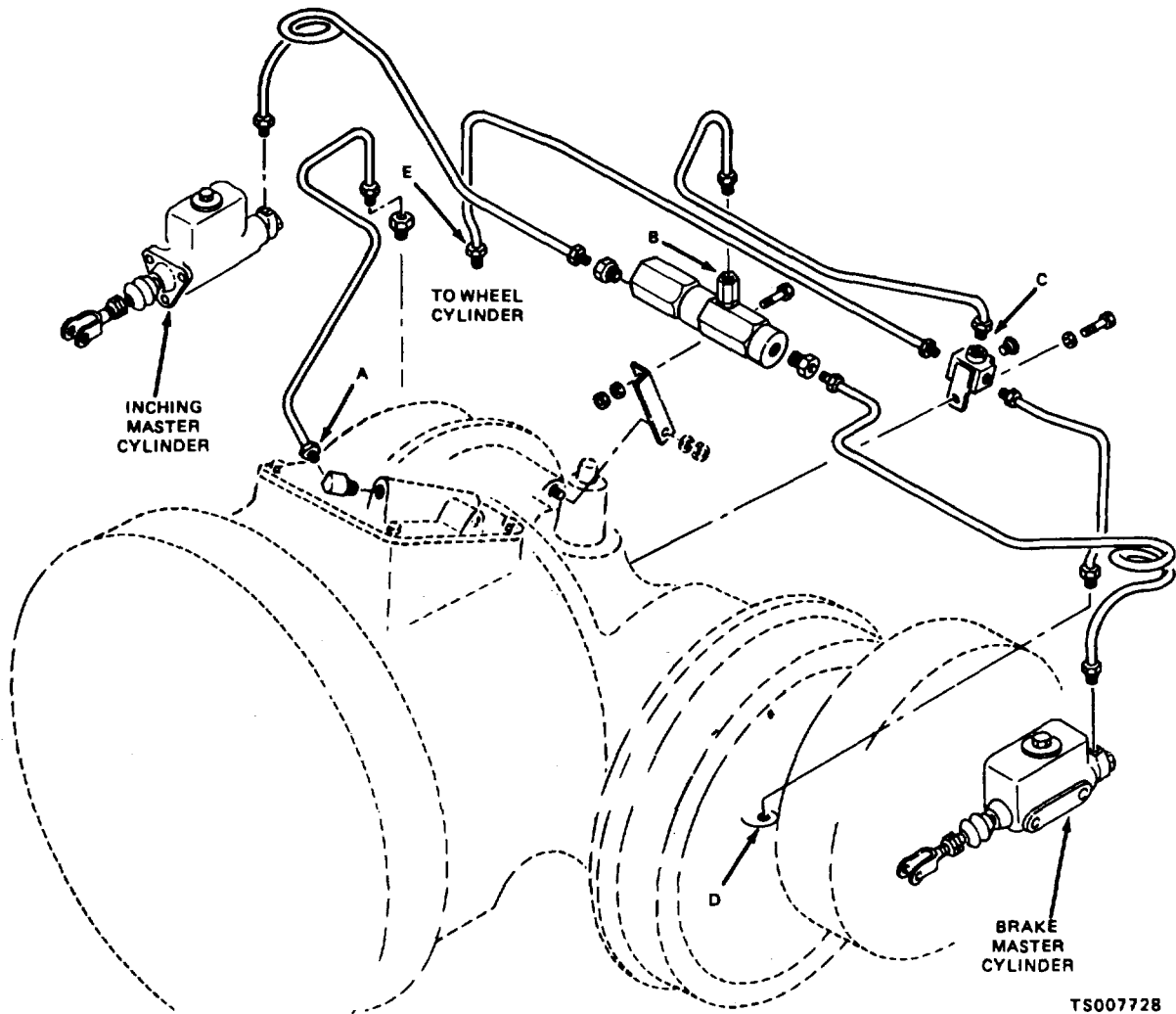

TS007728

Figure 4-55. Brake System Bleed Points

(g) When bleeding wheel cylinders (bleed points D and E), attach a small hose to the bleeder screw on the axle adapter, submerge the other end of the hose into a jar of clean brake fluid. Hold the jar at a point higher than the bleeder screw, and open the bleeder screw, allowing fluid to flow into the jar until no more bubbles can be seen in the flow.

(h) When air bubbles stop coming into the container, close the bleeder fitting and remove the tube. Close bleeder tank valve.

(i) Disconnect bleeder tank line from master cylinder and connect it to the inching master cylinder.

(j) Follow the same procedure as outlined above, but start at inching valve bleeding point.

(k) When bleeding operation is completed, fill both cylinders to with 1/4 inch from the top.

**WARNING**

Always relieve pressure from bleeder tank when bleeding operation is completed.

(2) *Manual Bleeding.* Manual bleeding may be performed when pressure bleeding equipment is unavailable. Manual bleeding will require two men, one to depress and hold the brake pedal while the other opens and closes the bleeder valves. Proceed as outlined under pressure bleeding, but observe the following special instructions:

(a) It must be remembered that the brake pedal should be depressed slowly and held until the line connections or bleeder screws are securely tightened. This prevents the possibility of air being drawn into the system during the bleeding operation. Check the master cylinder reservoir



level often during manual bleeding and keep with ¼ inch from the top.

(b) With filler cap off the master cylinder, depress and release brake pedal. A small displacement of fluid should be noticed in the cylinder reservoir. If this happens, the brake pedal (upon being released) is returning the master cylinder piston to its normal position to open a master cylinder port. This port must be open.

**4-76. Brake Master Cylinders**

**4-77. General**

The fork lift truck brake system consists of two separate master cylinders, one on each side of the truck. The cylinder on the right is the service brake master cylinder; utilized when making routine stops. The one on the left is the inching master cylinder. This cylinder enables the operator, through varying degrees of pedal pressure, to creep forward or backward to obtain an exact load pick-up/deposit position. The master cylinders are illustrated in figures 4-56 and 4-57.

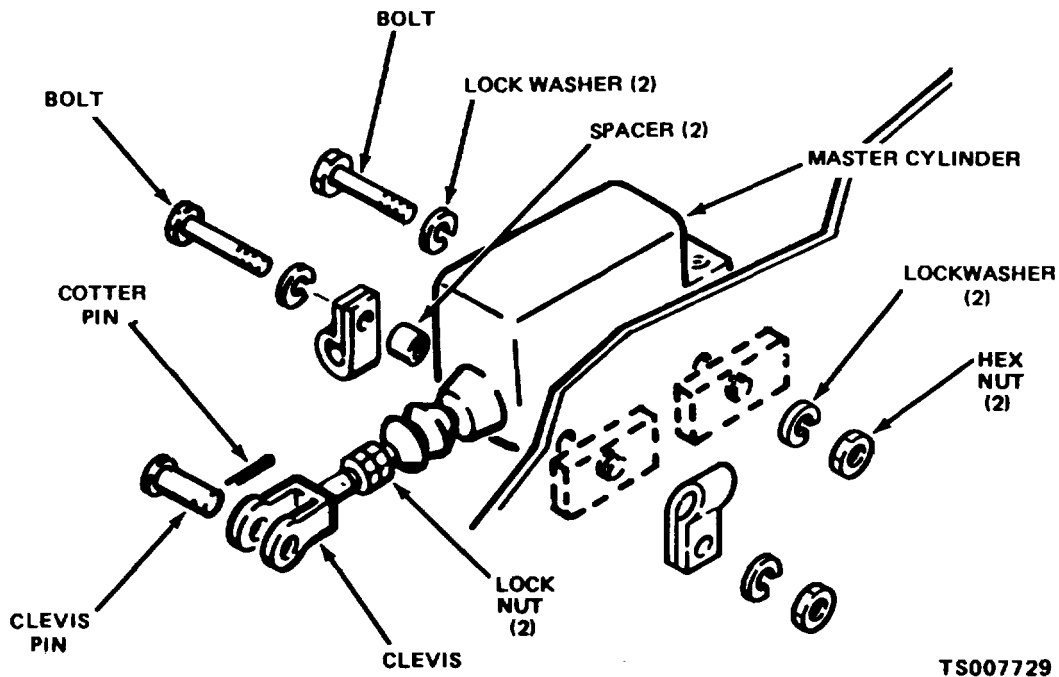

TS007729

Figure 4-56. Service Brake Master Cylinder, Removal and Installation

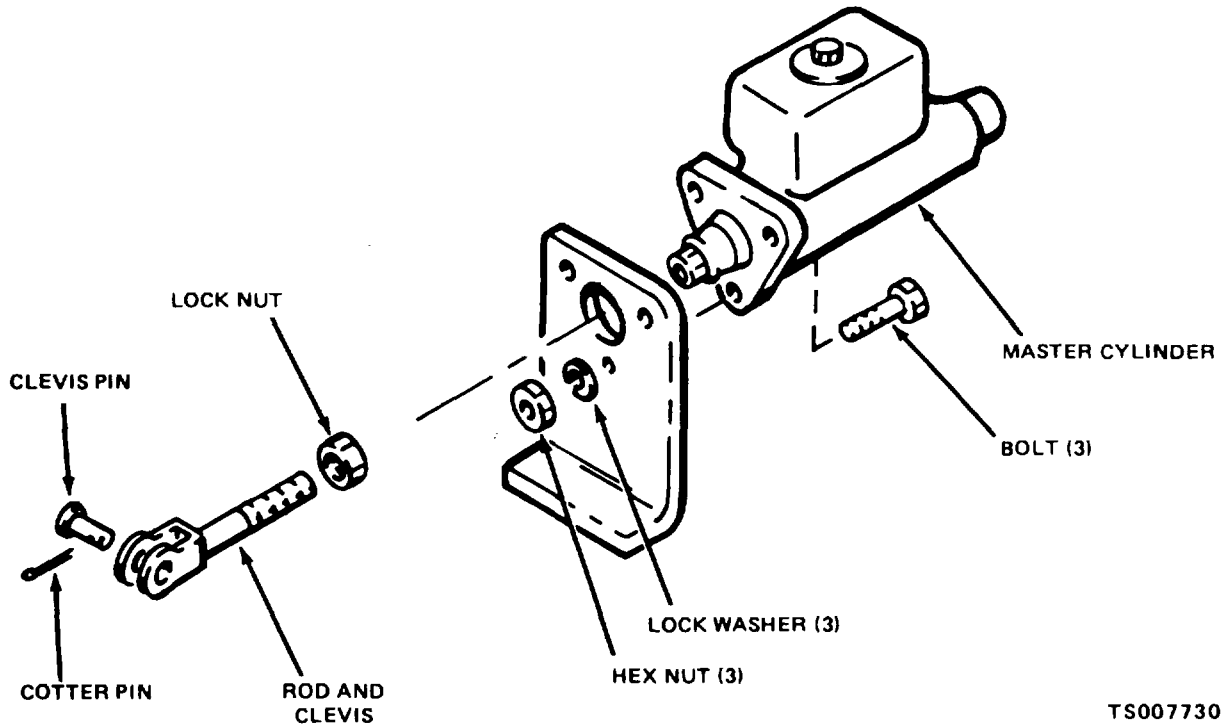

TS007730

Figure 4-57. Inching Brake Master Cylinder, Removal and Installation

*a. Removal*

- (1) Remove the accelerator pedal from floor plate.
- (2) Remove floor plate.
- (3) Disconnect hydraulic brake lines from master cylinder.

**CAUTION**

When disconnecting brake lines, take care to prevent dirt from entering the brake system.

- (4) Remove one or both master cylinders as shown in figures 4-56 and 4-57.

**WARNING**

Dry cleaning solvent, P-D-680, used to clean parts is potentially dangerous to personnel and property. Avoid repeated and prolonged skin contact. Do not use near open flame or excessive heat. Flash point of solvent is 100°F. -138°F. (380 ° C. -60°C.).

*b. Cleaning and Inspection.*

- (1) Clean the exterior of the master cylinders with a clean cloth dampened with dry cleaning solvent P-D-680.
- (2) Wipe the exterior of the brake lines and fittings with a cloth dampened with dry cleaning solvent P-D-680. Flush the interior of the lines with solvent. Blow dry with compressed air. To obtain the dimensions shown above, adjust the stop screws with

pedals at rest in the full "up" position. Loosen locknuts and turn the screws in or out as required. Tighten locknuts when the correct adjustment is obtained.

- (2) Hold a ruler vertically against some stationary point under the floor board so that the scale portion rests against the pedal pad of either pedal. Push on the pedal, by hand, noting the point at which resistance is felt. The pedal should travel a minimum of 1/8 inch and a maximum of 1/4 inch when resistance is felt. To adjust free play on either pedal, refer to figures 4-56 and 4-57, and remove the clevis pin from the master cylinder push rod clevis. Loosen locknuts on the clevis and turn clevis in or out as required. Turning clevis in will increase pedal free play; turning out will decrease free play. Tighten locknuts and install clevis pin when correct adjustment is obtained.

(3) Inspect the brake master cylinders for cracks, leaks and faulty operation; replace if damaged.

(4) Inspect the brake lines for cracks, dents, collapsed walls, restrictions, damaged threads, and other damage; replace damaged brake lines.

*c. Installation.*

- (1) Install the master cylinders as shown in figures 4-56 and 4-57.
- (2) Connect the brake lines as shown in figure 4-55.
- (3) Bleed the brake system as outlined in

paragraph 4-75d., after filling master cylinders with brake fluid. After bleeding, apply and hold the brakes firmly and check for leaks around connections.

**4-78. Brake Pedal and Linkage**

a. *Adjustment.* Brake and inching pedals and linkage must be adjusted to provide 1/8 to 1/4 inch free play. This adjustment is made in two steps. Proceed as follows:

(1) Remove floor plates to expose pedal arms, linkage, and master cylinders. Using a ruler

measure the distance from inside the front cowl to the farthest edge of the service and inching brake pedals. These should be:

Service brake pedal 9 3/8 to 9 5/8 in.

Inching brake pedal 8 5/8 to 8 3/4 in.

**NOTE**

The maximum pedal "UP" position is adjusted by means of stop screws which bear against the pedal brackets (fig. 4-58).

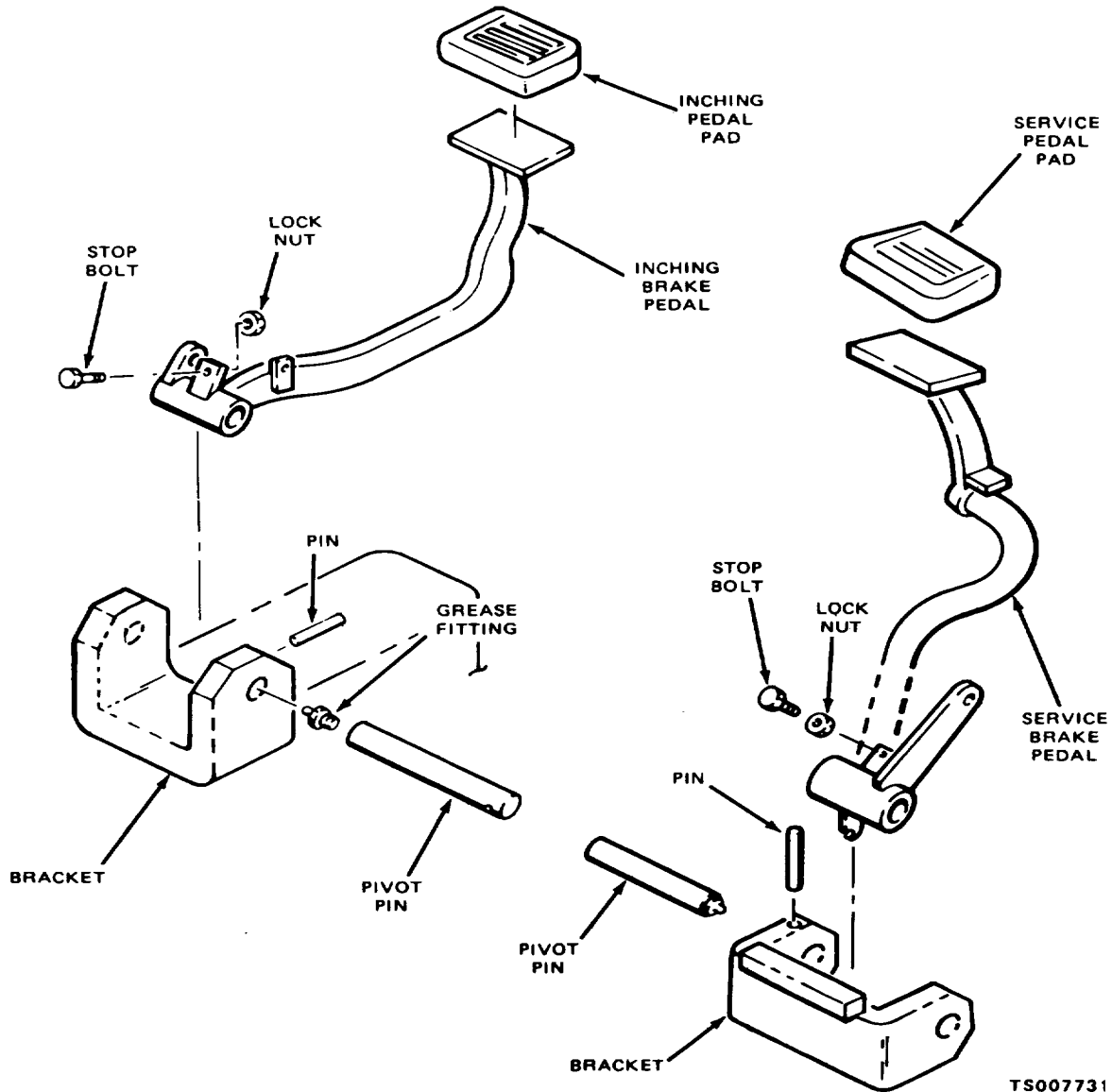

Figure 4-58. Brake Pedal and Linkage, Adjustment

Section XXI deleted.

#### **4-80. Differential**

*a. Service.*

(1) Locate drain plug -on the under side of the differential housing.

(2) Drain differential when hot. Allow to drain completely into a suitable container.

(3) Fill differential with oil as outlined in Lubrication Order LO 10-3930-632-12.

### **Section XXII. TRANSMISSION**

#### **4-81. General**

*a.* The transmission is mounted between the engine and drive axle assembly, immediately below the operator's compartment floor plates. The transmission is connected to the torque converter on one end and to the differential pinion gear on the other. It is a constant-mesh, full reversing, power-shifted type. The forward and reverse directions are selected by positioning the direction shift lever mounted on the steering column. The direction shift lever is connected by mechanical linkage to the selector lever on the top of the transmission.

*b.* The transmission fluid is cooled by heat-exchanger action in the lower part of the radiator. The fluid is pumped from the torque converter, through a filter, through the radiator and back to the transmission.

#### **4-82. Transmission Oil Filter and Lines**

*a. Filter Service.* Service the transmission oil filter as directed in paragraph 4-8, *e.*

*b. Removal and Disassembly.* Remove and disassemble the transmission oil filter and lines as shown in figure 4-60.

**Change 2 4-76**

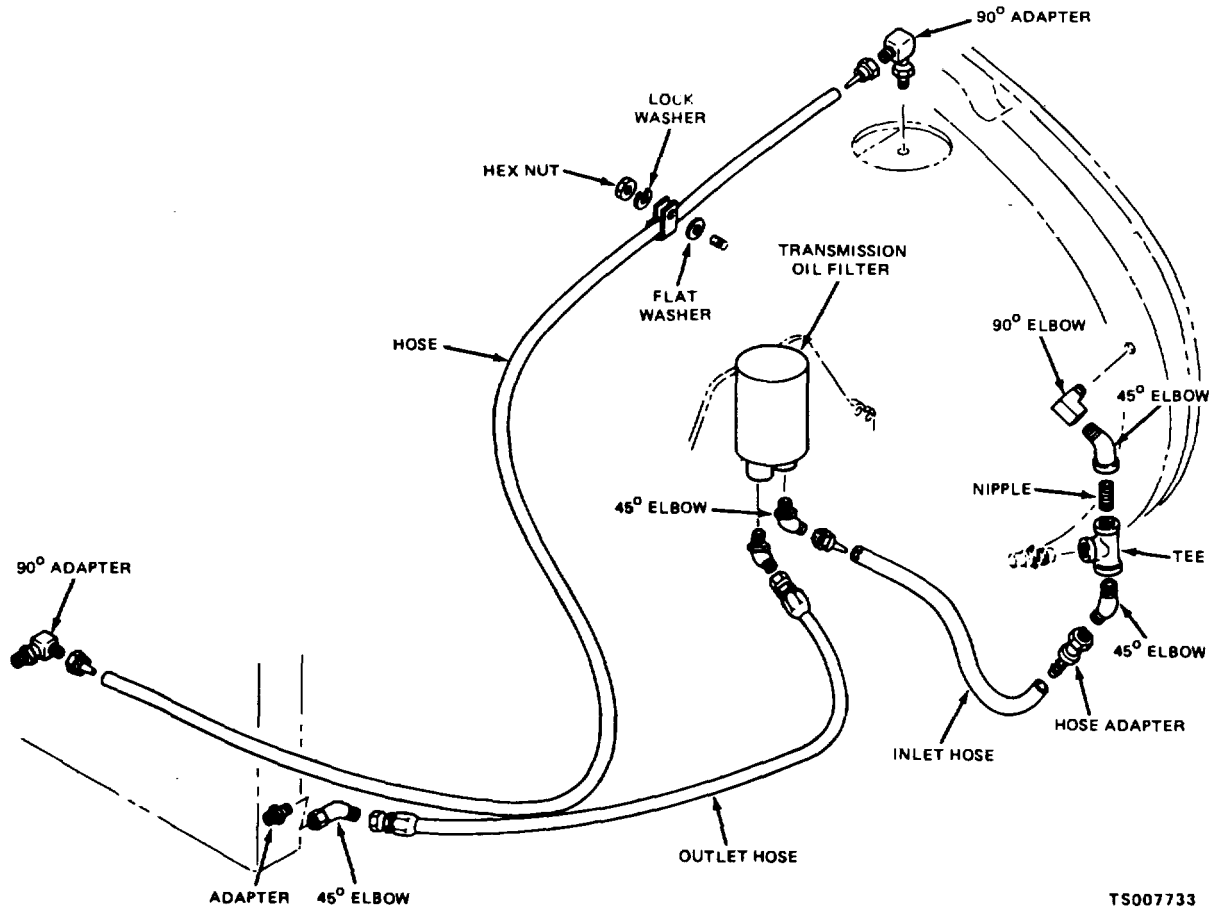

Figure 4-60. Transmission Oil Filter, Lines and Fittings, Removal and Installation

### WARNING

Dry cleaning solvent, P-D-680, used to clean parts is potentially dangerous to personnel and property. Avoid repeated and prolonged skin contact. Do not use near open flame or excessive heat. Flash point of solvent is 100 ° F. -138 ° F. (38 ° C. -60 ° C.).

#### c. Cleaning and Inspection.

(1) Discard and replace the transmission oil filter element.

(2) Wipe the exterior of the hoses with a cloth dampened with dry cleaning solvent P-D-680. Pour clean solvent through the hoses to flush them out. Blow clean, dry compressed air through the hoses to assure that they are free and clear. Clean all other parts with dry cleaning solvent P-D-680.

(3) Inspect the filter base for cracks, damaged threads, scratched or scored filter seat, and

other damage; replace a damaged filter base.

(4) Inspect the hoses for cracks, deterioration, abrasions, and damaged threads; replace damaged hoses.

(5) Inspect all other parts for cracks, distortion, and damaged threads; replace damaged parts.

d. *Reassembly and Installation.* Reassemble and install the transmission oil filter and lines as shown in figure 4-60, using a new filter element and gasket. After installation, start up the engine and check carefully for oil leaks. Repair any leaks and add oil as necessary.

### 4-83. Direction Shift Lever and Linkage Adjustment

a. Adjust the directional control lever and linkage as shown in figure 4-61.

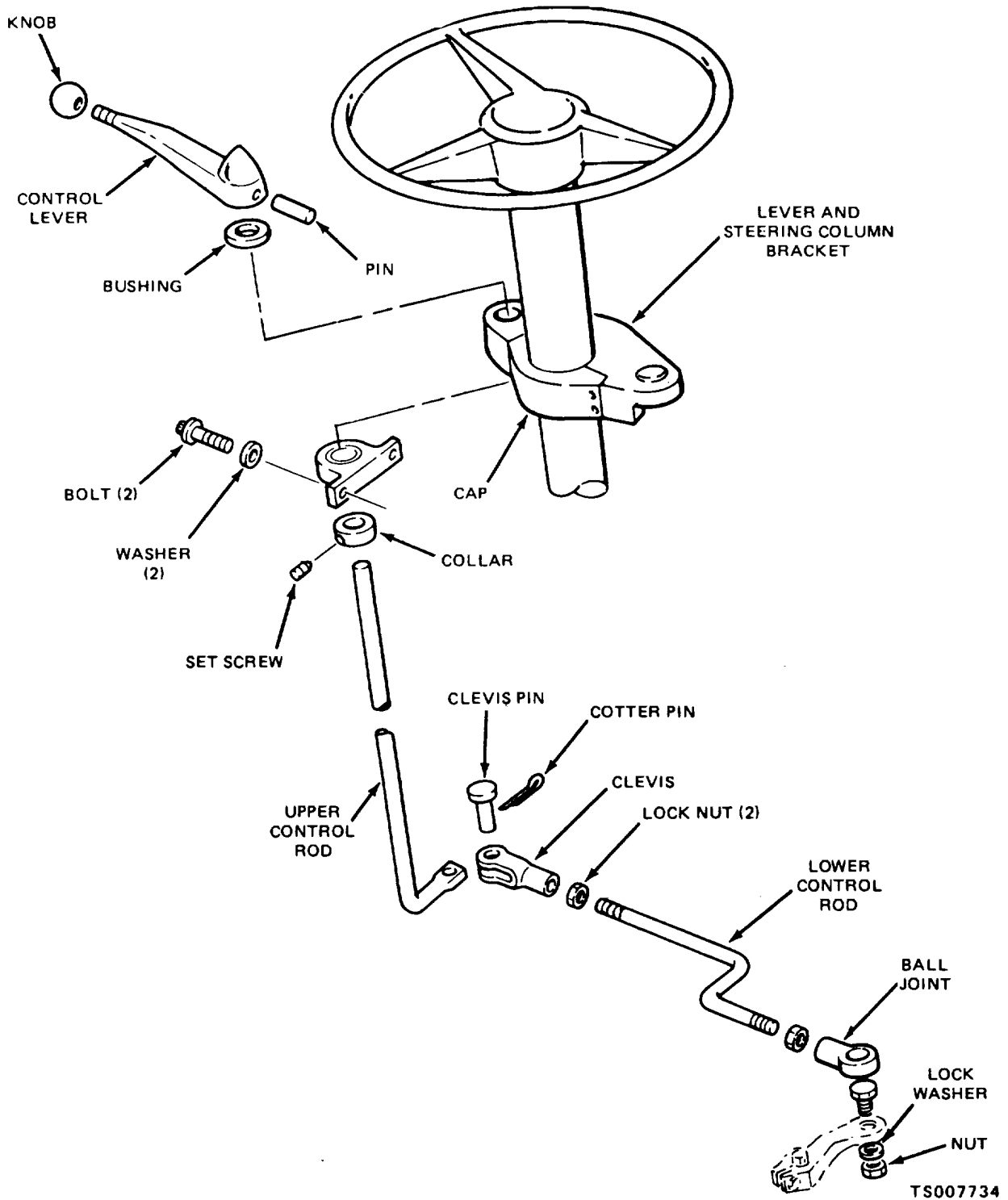

Figure 4-61. Directional Shift Lever and Linkage

b. Insure that center of shift lever knob is 2.40 inch to 2.90 inch in front of steering column centerline with transmission in neutral position.

c. Check to see that there is 3 inch minimum clearance between steering wheel and shift lever knob.

d. If a binding condition exists, adjust linkage to free binding. It must operate smoothly and engage/disengage transmission completely.

## APPENDIX A

## REFERENCES

- 
- |   |  |
|---|--|
| <b>A-1. Fire Protection</b>                                   |  |
| TB 5-4200-200-10  | Hand Portable Fire Extinguishers Approved for Army Users   |
| <b>A-2. Lubrication</b>                                       |  |
| C91001L   | Fuels, Lubricants, Oils and Waxes  |
| LO 10-3930-632-12   | Lubrication Order for Truck, Lift, Fork, Army Model MHE-229, Clark Model 2329397                               |
| <b>A-3. Painting</b>  |  |
| TM 43-0139  | Painting Instructions for Field Use  |
| <b>A-4. Radio Suppression</b>                                 |  |
| TM 11-483   | Radio Interference Suppression   |
| <b>A-5. Maintenance</b>                                       |  |
| TB ORD 651  | Use of Antifreeze Solutions and Cleaning Compounds in Engine Cooling Systems                                   |
| DA Pam 738-750  | The Army Maintenance Management System (TAMMS)   |
| TM 10-3930-632-34   | DS and GS Maintenance Manual for Truck, Lift, Fork, Army Model MHE-229, Clark Model 2329397                    |
| TM 10-3930-632-20P  | Organizational Maintenance Repair Parts Manual for Truck, Lift, Fork, Army Model MHE-229, Clark Model 2329397  |
| TM 20-3930-632-34P  | DS, GS, and Depot Maintenance Repair Parts List for Truck, Lift, Fork, Army Model MHE-229, Clark Model 2329397 |
| TM 9-6140-200-14  | Operation and Organizational Field and Depot Maintenance Storage Batteries, Lead Acid Type                     |
| TM 5-764  | Electric Motor and Generator Repair  |
| <b>A-6. Shipment and Storage</b>                              |  |
| TB 740-97-2   | Preservation of USAMEC Mechanical Equipment for Shipment and Storage   |
| TM 740-90-1   | Administrative Storage of Equipment  |
| <b>A-7. Destruction of Army Materiel to Prevent Enemy Use</b> |  |
| TM 750-244-3  | Procedures for Destruction of Equipment to Prevent Enemy Use (Mobility Equipment Command)                      |

## APPENDIX B

## MAINTENANCE ALLOCATION CHART

## Section I. INTRODUCTION

**B-1. General**

a. This section provides a general explanation of all maintenance and repair functions authorized at various maintenance categories

b. The Maintenance Allocation Chart (MAC) in section II designates overall authority and responsibility for the performance of maintenance functions on the identified end item or component. The application of the maintenance function on the end item or component will be consistent with the capacities and capabilities of the designated maintenance categories.

c. Section III lists the tools and test equipment (both special tools and common tool sets) required for each maintenance function as referenced from section II.

d. Section IV contain supplemental instructions and explanatory notes for a particular maintenance function.

**B-2. Maintenance Functions.** Maintenance functions will be limited to and defined as follows:

a. *Inspect.* To determine the serviceability of an item by comparing its physical, mechanical, and/or electrical characteristics with established standards through examination (e.g., by sight, sound, or feel).

b. *Test.* To verify serviceability by measuring the mechanical, pneumatic, hydraulic, or electrical characteristics of an item and comparing those characteristics with prescribed standards.

c. *Service.* Operations required periodically to keep an item in proper operating condition, i.e., to clean (including decontaminate, when required), preserve, drain, paint, or replenish fuel, lubricants, chemical fluids, or gases.

d. *Adjust.* To maintain or regulate, within prescribed limits, by bringing into proper or exact position, or by setting the operating characteristics to specified parameters.

e. *Align.* To adjust specified variable elements of an item to bring about optimum or desired performance.

f. *Calibrates.* To determine and cause correction to be made or to be adjusted on instruments or test, measuring, and diagnostic equipment used in precision measurement. Consists of comparisons of two instruments, one of which is a certified standard of known accuracy, to detect and adjust any discrepancy in the accuracy of the instrument being compared.

g. *Remove/Install.* To remove and install the same item when required to perform service or other maintenance functions. Install may be the act of emplacing, eating, or fixing into position a space, repair part, or module (component or assembly) in a manner to allow the proper functioning of an equipment or system.

h. *Replace.* To remove an unserviceable item and in-al a serviceable counterpart in its place. "Replace" is authorized by the MAC and is shown as the third position of the SMR code.

i. *Repair.* The application of maintenance service<sup>1</sup>, including fault location/troubleshooting<sup>2</sup>, removal/installation, disassembly/assembly<sup>3</sup> procedures, and maintenance actions<sup>4</sup> to identify troubles and restore serviceability to an item by correcting specific damage, fault, malfunction, or failure in a part, subassembly, module (component or assembly), end item, or system.

<sup>1</sup>Service - inspect, test, service, adjust, align, calibrate, and/or replace.

<sup>2</sup>Fault location/troubleshooting - The process of investigating and detecting the cause of equipment malfunctioning; the act of isolating a fault within a system or unit under test (UUT).

<sup>3</sup>Disassembly/assembly - encompasses the step-by-step taking apart (or breakdown) of a spare/functional group coded item to the level of its least componentry identified as maintenance significant (i.e., aligned an SMR code) for the category of maintenance under consideration.

<sup>4</sup>Action - welding, grinding, riveting, straightening, facing, remachining, and/or resurfacing.



*j. Overhaul.* That maintenance effort (service/action) prescribed to restore an item to a completely serviceable/operational condition as required by maintenance standards in appropriate technical publication (i.e., DMWR). Overhaul is normally the highest degree of maintenance performed by the Army. Overhaul does not normally return an item to like-new condition.

*k. Rebuild.* Consists of those services/actions necessary for the restoration of unserviceable equipment to a like-new condition in accordance with original manufacturing standards. Rebuild is the highest degree of material maintenance applied to Army equipment. The rebuild operation includes the act of returning to zero those age measurements (hours/miles, etc.) considered in classifying Army equipment/components.

**B-3. Explanation of Columns in the MAC, Section II**

*a. Column 1, Group Number.* Column 1 lists functional group code numbers, the purpose of which is to identify maintenance significant components, assemblies, subassemblies, and modules with the next higher assembly. End item group number shall be "00".

*b. Column 2, Component/Assembly.* Column 2 contains the names of components, assemblies, subassemblies, and modules for which maintenance is authorized.

*c. Column 3, Maintenance Function.* Column 3 lists the function to be performed on the item listed in Column 2. (For detailed explanation of these functions, see paragraph C-2).

*d. Column 4, Maintenance Category.* Column 4 specifies, by the listing of a worktime figure in the appropriate subcolumns, the category of maintenance authorized to perform the function listed in column 3. This figure represents the active time required to perform that maintenance function at the indicated category of maintenance. If the number or complexity of the task within the listed maintenance function vary at different maintenance categories, appropriate worktime figures will be shown for each category. The worktime figure represents the average time required to restore an item (assembly, subassembly, component, module, end item, or system) to a serviceable condition under

typical field operating conditions. This time includes preparation time (including any necessary disassembly/assembly time, troubleshooting/fault location time, and quality assurance/quality control time in addition to the time required to perform a specific task identified for the maintenance functions authorized in the maintenance allocation chart. The symbol designations for the various maintenance categories are as follows:

- C - Operator or Crew
- O - Organizational Maintenance
- F - Direct Support Maintenance
- H - General Support Maintenance
- D - Depot Maintenance

*e. Column 5, Tools and Equipment.* Column 5 specifies by code, those common tool sets (not individual tools) and special tools, TMDE, and support equipment required to perform the designated function.

*f. Column 6, Remarks.* This column shall, when applicable, contain a letter code, in alphabetical order, which shall be keyed to the remarks contained in Section IV.

**B-4. Explanation of Columns in Tool and Test Equipment Requirements, Section III**

*a. column 1, Reference Code.* The tool and test equipment reference code correlates with a code used in the MAC, Section II, Column 5.

*b. Column 2, Maintenance Category.* The lowest category of maintenance authorized to use the tool or test equipment.

*c. Column 3, Nomenclature.* Name or identification of the tool or test equipment.

*d. Column 4, National Stock Number.* The National stock number of the tool or test equipment.

*e. Column 5, Tool Number.* The manufacturer's part number.

**B-5. Explanation of Columns in Remarks, Section IV**

*a. Column 1, Reference Code.* The code recorded in column 6, Section II.

*b. Column 2, Remarks.* This column lists information pertinent to the maintenance function being performed as indicated in the MAC, Section II.

Section II. MAINTENANCE ALLOCATION CHART

| (1)<br>GROUP<br>NUMBER | (2)<br>COMPONENT/ASSEMBLY                            | (3)<br>MAINTENANCE<br>FUNCTION                              | (4)<br>MAINTENANCE CATEGORY |                          |                          |              |   | (5)<br>TOOLS AND<br>EQUIPMENT | (6)<br>REMARKS |
|------------------------|--|---|-----------------------------|--------------------------|--------------------------|--------------|---|-------------------------------|----------------|
|                        |  |   | C                           | O                        | F                        | H            | D |                               |                |
| 01<br>0100             | ENGINE<br>Engine Assembly                            | Inspect<br>Test<br>Service<br>Replace<br>Repair<br>Overhaul | 0.1<br><br>0.4              | 1.0                      | 8.0                      | 12.0<br>28.0 |   |                               | B              |
| 0101                   | Crankcase, Block<br>and Cylinder Head                | Replace   |                             |                          | 2.0                      |              |   |                               |                |
| 0102                   | Cylinder Head  | Replace   |                             |                          | 12.0                     |              |   |                               | B              |
| 0103                   | Crankshaft   | Replace   |                             |                          | 2.0                      |              |   |                               |                |
| 0104                   | Flywheel Assembly                                    | Replace   |                             |                          | 1.0                      |              |   |                               |                |
| 0104                   | Pistons, Connecting<br>Rods                          | Replace<br>Repair   |                             |                          |                          | 4.0<br>4.0   |   |                               |                |
| 0105                   | Valves, Camshafts<br>and Timing System               | Engine Valves   |                             |                          | 1.0<br>4.0<br>2.0        |              |   |                               | D              |
| 0106                   | Timing Gears<br>Camshaft Assembly                    | Adjust<br>Replace<br>Repair<br>Replace                      |                             |                          | 1.0<br>4.0<br>2.0<br>1.0 | 8.0          |   |                               |                |
| 0106                   | Engine Lubrication<br>System                         | Replace   |                             |                          | 2.0                      |              |   |                               |                |
| 0106                   | Oil Pump   | Repair  |                             |                          | 1.0                      |              |   |                               |                |
| 0106                   | Oil Filter   | Service<br>Replace<br>Repair<br>Replace                     |                             | 0.1<br>0.2<br>0.2<br>0.5 |                          |              |   |                               |                |
| 0108                   | Manifolds  | Replace   |                             |                          | 0.5                      |              |   |                               |                |
| 03<br>0301             | FUEL SYSTEM<br>Carburetor                            | Adjust<br>Replace<br>Repair                                 |                             | 0.3<br>0.3               | 2.0                      |              |   |                               |                |
| 0302                   | Fuel Pump  | Test<br>Replace   |                             | 0.3<br>0.4               |                          |              |   |                               |                |
| 0304                   | Air Cleaner w/<br>Indicator                          | Replace<br>Repair   |                             | 0.3<br>0.3               |                          |              |   |                               |                |
| 0306                   | Tanks, Lines,<br>Fittings, Headers<br>Fuel Lines     | Inspect<br>Replace  | 0.1                         | 0.3                      |                          |              |   |                               | A              |
| 0308                   | Engine Speed<br>Governor and<br>Controls<br>Governor | Adjust<br>Replace   |                             | 0.2                      | 1.4                      |              |   |                               |                |

Section II. MAINTENANCE ALLOCATION CHART

| (1)<br>GROUP<br>NUMBER | (2)<br>COMPONENT/ASSEMBLY                | (3)<br>MAINTENANCE<br>FUNCTION | (4)<br>MAINTENANCE CATEGORY |     |     |     |   | (5)<br>TOOLS AND<br>EQUIPMENT | (6)<br>REMARKS |
|------------------------|--|--------------------------------|-----------------------------|-----|-----|-----|---|-------------------------------|----------------|
|                        |  |                                | C                           | O   | F   | H   | D |                               |                |
| 0309                   | Fuel Filter                              | Replace                        |                             | 0.4 |     |     |   |                               |                |
|                        |  | Repair                         |                             | 0.4 |     |     |   |                               |                |
| 0312                   | Accelerator Pedal<br>and Linkage         | Adjust                         |                             | 0.5 |     |     |   |                               |                |
|                        |  | Replace                        |                             | 0.5 |     |     |   |                               | A              |
| 04                     | EXHAUST SYSTEM                           |                                |                             |     |     |     |   |                               |                |
| 0401                   | Muffler and Pipes                        | Replace                        |                             | 1.0 |     |     |   |                               |                |
| 05                     | COOLING SYSTEM                           |                                |                             |     |     |     |   |                               |                |
| 0501                   | Radiator                                 | Inspect                        | 0.1                         |     |     |     |   |                               |                |
|                        |  | Service                        | 0.2                         |     |     |     |   |                               |                |
|                        |  | Replace                        |                             | 1.5 |     |     |   |                               |                |
|                        |  | Repair                         |                             |     |     | 2.0 |   |                               |                |
| 0503                   | Thermostat, Hoses<br>and Related Parts   | Test                           |                             | 0.3 |     |     |   |                               |                |
|                        |  | Replace                        |                             | 0.5 |     |     |   |                               | A              |
| 0504                   | Water Pump                               | Inspect                        | 0.1                         |     |     |     |   |                               |                |
|                        |  | Replace                        |                             | 1.0 |     |     |   |                               |                |
|                        |  | Repair                         |                             |     | 1.0 |     |   |                               |                |
| 0505                   | Blade, Fan<br>Belts                      | Replace                        |                             | 0.2 |     |     |   |                               |                |
|                        |  | Inspect                        | 0.1                         |     |     |     |   |                               |                |
|                        |  | Adjust                         |                             | 0.2 |     |     |   |                               |                |
|                        |  | Replace                        |                             | 0.3 |     |     |   |                               |                |
| 06                     | ELECTRICAL<br>SYSTEM                     |                                |                             |     |     |     |   |                               |                |
| 0601                   | Alternator                               | Test                           |                             | 0.3 |     |     |   |                               |                |
|                        |  | Replace                        |                             | 0.4 |     |     |   |                               |                |
|                        |  | Repair                         |                             |     | 2.0 |     |   |                               |                |
| 0602                   | Voltage Regulator                        | Test                           |                             | 0.3 |     |     |   |                               |                |
|                        |  | Adjust                         |                             | 0.2 |     |     |   |                               |                |
|                        |  | Replace                        |                             | 0.2 |     |     |   |                               |                |
| 0603                   | Starting Motor                           | Test                           |                             | 0.3 |     |     |   |                               |                |
|                        |  | Replace                        |                             | 0.5 |     |     |   |                               |                |
|                        |  | Repair                         |                             |     | 2.0 |     |   |                               |                |
| 0605                   | Ignition Components<br>Distributor       | Service                        |                             | 0.2 |     |     |   |                               |                |
|                        |  | Adjust                         |                             | 0.3 |     |     |   |                               |                |
|                        |  | Replace                        |                             | 0.5 |     |     |   |                               |                |
|                        |  | Repair                         |                             | 1.0 |     |     |   |                               |                |
|                        | Spark Plugs                              | Adjust                         |                             | 0.2 |     |     |   |                               |                |
|                        |  | Replace                        |                             | 0.4 |     |     |   |                               |                |
| 0607                   | Instrument Panel<br>and Instruments      | Replace                        |                             | 0.5 |     |     |   |                               |                |
| 0608                   | Fuses                                    | Replace                        |                             | 0.2 |     |     |   |                               |                |
| 0609                   | Lights                                   | Test                           | 0.1                         |     |     |     |   |                               |                |
|                        |  | Replace                        |                             | 0.3 |     |     |   |                               | A              |
| 0610                   | Sending Units<br>and Warning<br>Switches | Replace                        |                             | 0.4 |     |     |   |                               |                |

Section II. MAINTENANCE ALLOCATION CHART

| (1)<br>GROUP<br>NUMBER | (2)<br>COMPONENT/ASSEMBLY  | (3)<br>MAINTENANCE<br>FUNCTION | (4)<br>MAINTENANCE CATEGORY |     |     |      |   | (5)<br>TOOLS AND<br>EQUIPMENT | (6)<br>REMARKS |
|------------------------|--|--------------------------------|-----------------------------|-----|-----|------|---|-------------------------------|----------------|
|                        |  |                                | C                           | O   | F   | H    | D |                               |                |
| 0611                   | Horn   | Test                           | 0.1                         |     |     |      |   |                               |                |
| 0612                   | Battery  | Replace                        |                             | 0.3 |     |      |   |                               |                |
|                        |  | Inspect                        | 0.1                         |     |     |      |   |                               |                |
|                        |  | Test                           |                             | 0.2 |     |      |   |                               |                |
|                        |  | Service                        |                             | 0.2 |     |      |   |                               |                |
|                        |  | Replace                        |                             | 0.3 |     |      |   |                               |                |
|                        |  | Repair                         |                             |     |     | 1.3  |   |                               |                |
| 0613                   | Chassis Wiring<br>Harness  | Inspect                        |                             | 0.3 |     |      |   |                               |                |
|                        |  | Replace                        |                             | 1.0 |     |      |   |                               |                |
| 0615                   | Radio Interference<br>Suppression  | Replace                        |                             | 0.2 |     |      |   |                               |                |
| 07<br>0705             | TRANSMISSION<br>Gear Shift<br>Control Lever and<br>Linkage               | Adjust                         |                             | 0.5 |     |      |   |                               |                |
|                        |  | Replace                        |                             |     | 2.0 |      |   |                               |                |
| 0708                   | Torque Converter   | Replace                        |                             |     | 0.5 |      |   |                               |                |
| 0710                   | Transmission<br>Assembly   | Inspect                        | 0.1                         |     |     |      |   |                               |                |
|                        |  | Test                           |                             |     | 2.0 |      |   |                               | F              |
|                        |  | Service                        | 0.2                         | 0.5 |     |      |   |                               |                |
|                        |  | Replace                        |                             |     | 8.0 |      |   |                               |                |
|                        |  | Repair                         |                             |     |     | 12.0 |   |                               |                |
|                        |  | Overhaul                       |                             |     |     | 16.0 |   |                               |                |
| 0713                   | Intermediate<br>Clutches   | Replace                        |                             |     |     | 4.0  |   |                               |                |
|                        |  | Repair                         |                             |     |     | 6.0  |   |                               |                |
| 0714                   | Servo Unit   | Replace                        |                             |     | 1.0 |      |   |                               |                |
|                        |  | Repair                         |                             |     | 2.0 |      |   |                               |                |
| 0721                   | Coolers, Pumps,<br>Motors<br>Transmission<br>Oil Filter<br>Hose Assembly | Replace                        |                             | 0.2 |     |      |   |                               |                |
|                        |  | Replace                        |                             | 1.0 |     |      |   |                               |                |
|                        |  | Repair                         |                             |     | 1.0 |      |   |                               |                |
| 10<br>1000             | FRONT AXLE<br>Front Axle<br>Assembly<br>Drive Axle Ends                  | Replace                        |                             |     |     | 2.0  |   |                               |                |
|                        |  | Repair                         |                             |     |     | 3.0  |   |                               | A              |
| 1002                   | Differential   | Service                        |                             | 0.2 |     |      |   |                               |                |
|                        |  | Replace                        |                             |     | 4.0 |      |   |                               |                |
|                        |  | Repair                         |                             |     |     | 8.0  |   |                               |                |
| 11                     | REAR AXLE  |                                |                             |     |     |      |   |                               |                |
|                        |  | <b>Change 2</b>                | <b>B-5</b>                  |     |     |      |   |                               |                |

Section II. MAINTENANCE ALLOCATION CHART

| (1)<br>GROUP<br>NUMBER | (2)<br>COMPONENT/ASSEMBLY  | (3)<br>MAINTENANCE<br>FUNCTION                   | (4)<br>MAINTENANCE CATEGORY |                   |                   |     |   | (5)<br>TOOLS AND<br>EQUIPMENT | (6)<br>REMARKS |
|------------------------|--|--|-----------------------------|-------------------|-------------------|-----|---|-------------------------------|----------------|
|                        |  |  | C                           | O                 | F                 | H   | D |                               |                |
| 1104                   | Steering and Wheel<br>Leaning Mechanism<br>Steering Axle<br>Assembly | Service<br>Replace                               |                             | 0.3               | 3.0               |     |   |                               | E              |
|                        | Tie Rod  | Repair<br>Service<br>Adjust<br>Replace<br>Repair |                             | 0.1<br>0.5        | 2.0<br>2.0<br>0.5 |     |   |                               |                |
| 12<br>1201             | BRAKES<br>Hand Brakes<br>Hand Brake Lever                            | Service<br>Adjust<br>Replace                     |                             | 0.1<br>0.2<br>0.5 |                   |     |   |                               |                |
| 1202                   | Service Brakes<br>Service Brake<br>Shoes                             | Replace<br>Repair                                |                             |                   | 1.5<br>1.0        |     |   |                               | A              |
| 1204                   | Hydraulic Brake<br>System<br>Wheel Cylinders                         | Replace<br>Repair                                |                             |                   | 0.3<br>0.5        |     |   |                               | A              |
|                        | Master Cylinder  | Service<br>Replace<br>Repair                     |                             | 0.1<br>1.0        | 1.0               |     |   |                               |                |
|                        | Inching Cylinder   | Service<br>Replace<br>Repair                     |                             | 0.1<br>1.0<br>1.0 |                   |     |   |                               |                |
| 1206                   | Mechanical Brake<br>System<br>Brake Pedal<br>Linkage                 | Service<br>Adjust<br>Replace                     |                             | 0.1<br>0.2<br>0.5 |                   |     |   |                               |                |
| 13<br>1311             | WHEELS and<br>TRACKS<br>Wheel Assembly                               | Replace<br>Repair                                |                             | 1.0               |                   | 1.0 |   |                               | A              |
|                        | Wheel Bearings<br>and Seals  | Service<br>Replace                               |                             | 0.5<br>1.0        |                   |     |   |                               | A<br>A         |
| 1313                   | Tires  | Inspect<br>Replace                               | 0.1                         |                   |                   | 1.0 |   |                               |                |
| 14<br>1401             | STEERING<br>Mechanical<br>Steering Gear<br>System                    | Service<br>Replace                               |                             | 0.1               | 4.0               |     |   |                               |                |

Section II. MAINTENANCE ALLOCATION CHART

| (1)<br>GROUP<br>NUMBER | (2)<br>COMPONENT/ASSEMBLY                                       | (3)<br>MAINTENANCE<br>FUNCTION                           | (4)<br>MAINTENANCE CATEGORY |                          |                   |   |   | (5)<br>TOOLS AND<br>EQUIPMENT | (6)<br>REMARKS |
|------------------------|---|--|-----------------------------|--------------------------|-------------------|---|---|-------------------------------|----------------|
|                        |   |  | C                           | O                        | F                 | H | D |                               |                |
| 1401                   | Mechanical<br>Steering Gear<br>System - Continued<br>Drag Links | Service<br>Adjust<br>Replace<br>Repair                   |                             | 0.1<br>1.0<br>2.0<br>0.5 |                   |   |   |                               |                |
| 15                     | FRAME TOWING<br>ATTACHMENTS<br>and DRAWBARS                     |  |                             |                          |                   |   |   |                               |                |
| 1502                   | Counterweights  | Replace  |                             | 0.7                      |                   |   |   |                               |                |
| 18                     | BODY, CAB and<br>HOOD   |  |                             |                          |                   |   |   |                               |                |
| 1801                   | Overhead Guard  | Inspect<br>Replace                                       | 0.1                         | 1.0                      |                   |   |   |                               | A              |
|                        | Body Panels<br>and Hoods  | Inspect<br>Replace                                       | 0.1                         | 0.5                      |                   |   |   |                               | A              |
| 1806                   | Operator's Seat   | Adjust<br>Replace  | 0.1                         | 0.5                      |                   |   |   |                               |                |
| 24                     | HYDRAULIC LIFT<br>COMPONENTS                                    |  |                             |                          |                   |   |   |                               |                |
| 2401                   | Hydraulic Pump  | Test<br>Replace<br>Repair                                |                             |                          | 1.0<br>2.0<br>4.0 |   |   |                               | A              |
| 2402                   | Hydraulic<br>Control Valve                                      | Replace<br>Repair  |                             |                          | 1.5<br>1.0        |   |   |                               |                |
| 2403                   | Tilt Lock Valve<br>Control Levers<br>and Linkage                |  |                             |                          | 0.3               |   |   |                               |                |
| 2404                   | Tilt Cylinder   | Replace<br>Service<br>Adjust<br><b>Replace</b><br>Repair |                             | 0.1<br>0.3<br>0.5        | 2.0               |   |   |                               |                |
| 2405                   | Hydraulic Mast<br>Column<br>Mast Assembly                       | Inspect<br>Service<br>Adjust<br><b>Replace</b><br>Repair |                             | 0.1<br>0.3<br>1.0        | 2.0<br>1.0        |   |   |                               | A              |
|                        | Lift Chains   | Inspect<br>Adjust  |                             | 0.1<br>0.5               |                   |   |   |                               |                |
|                        | Lift Cylinder   | Replace<br>Replace<br>Repair                             |                             | 2.0                      | 2.0<br>4.0        |   |   |                               |                |

**Section II. MAINTENANCE ALLOCATION CHART**

| (1)<br>GROUP<br>NUMBER | (2)<br>COMPONENT/ASSEMBLY       | (3)<br>MAINTENANCE<br>FUNCTION | (4)<br>MAINTENANCE CATEGORY |     |     |   |   | (5)<br>TOOLS AND<br>EQUIPMENT | (6)<br>REMARKS |
|------------------------|---------------------------------|--------------------------------|-----------------------------|-----|-----|---|---|-------------------------------|----------------|
|                        |                                 |                                | C                           | O   | F   | H | D |                               |                |
| 2406                   | Hydraulic Lines<br>and Fittings | Inspect                        |                             | 0.5 |     |   |   |                               |                |
|                        |                                 | Replace                        |                             | 1.0 |     |   |   |                               |                |
|                        |                                 | Repair                         |                             |     | 0.5 |   |   |                               |                |
| 2408                   | Filter Assembly,<br>Hydraulic   | Replace                        |                             | 1.0 |     |   |   |                               |                |
|                        | Hydraulic<br>Reservoir          | Service                        |                             |     |     |   |   |                               |                |
|                        |                                 | Replace                        |                             |     |     |   |   |                               |                |

**Change 2 B-8**

**Section III. TOOL AND TEST EQUIPMENT REQUIREMENTS**

| Tool or test equipment ref code | Maintenance category | Nomenclature | National stock number | Tool number |
|---------------------------------|----------------------|--------------|-----------------------|-------------|
|---------------------------------|----------------------|--------------|-----------------------|-------------|

NOT APPLICABLE

**Section IV. REMARKS**

| Reference Code | Remarks  |
|----------------|--|
| A              | Estimated single unit manhour repair or replacement. |
| B              | Test includes engine operation and compression.      |
| C              | Align and resize.                                    |
| D              | Reface.  |
| E              | Align and Adjust.                                    |
| F              | Test hydraulic control pressure.                     |

**Change 2 B-9**



APPENDIX C

BASIC ISSUE ITEMS LIST AND ITEMS TROOP

INSTALLED OR AUTHORIZED LIST

Section I. INTRODUCTION

**C-1. Scope**

This appendix lists basic issue items, items troop installed or authorized which accompany the fork lift truck and are required by the crew/operator for operation, installation, or operator's maintenance.

**C-2. General**

This basic issue items, items troop installed or authorized list and repair parts and special tools list is divided into the following sections:

a. *Basic Issue Items List-Section II.* Not applicable.

b. *Items Troop Installed or Authorized List-Section III.* A list in alphabetical sequence of items which at the discretion of the unit commander may accompany the end items, but are NOT subject to be turned in with the end item.

c. *Repair Parts and Special Tools List-Section IV.* Refer to TM 10-3930-632-20P and TM 10-3930-632-34P.

**C-3. Explanation of Columns**

The following provides an explanation of columns in the tabular list of Basic Issue Items List, Section II, and Items Troop Installed or Authorized List, Section III.

a. *Source, Maintenance and Recoverability Code (s) (I SMR):* Not applicable.

b. *National Stock Number.* This column indicates the National stock number assigned to the item and will be used for requisitioning purposes.

c. *Description.* This column indicates the Federal item name and any additional description of the item required.

d. *Unit of Measure (U/M).* A 2 character alphabetic abbreviation indicating the amount of quantity of the item upon which the allowances are based, e.g., ea, pr, etc.

e. *Quantity Authorized (Items Troop Installed or Authorized Only).* This column indicates the quantity of the item authorized to be used with the equipment.

Section III. ITEMS TROOP INSTALLED OR AUTHORIZED LIST

| SMR Code | National Stock Number | Description                             | Usable on Code | UNIT OF MEAS. | QTY | AUTH |
|----------|-----------------------|---|----------------|---------------|-----|------|
|          | 7520-00-559-9618      | CASE, Maintenance and Operation Manual. |                | ea            | 1   | 1    |
|          | 4210-00-889-2221      | Extinguisher, Fire                      |                | ea            | 1   | 1    |

Change 2 C-1

INDEX

|                                     | Paragraph | Page |                                       | Paragraph | Page |
|-------------------------------------|-----------|------|---------------------------------------|-----------|------|
| <b>A</b>                            |           |      |                                       |           |      |
| Accelerator pedal and linkage:      |           |      | Cleaning:                             |           |      |
| Cleaning and inspection .....       | 4-60      | 4-48 | Battery.....                          | 4-37      | 4-39 |
| Reassembly and installation .....   | 4-50      | 4-48 | During lubrication.....               | 3-2       | 3-1  |
| Removal and disassembly .....       | 4-50      | 4-48 | Hydraulic oil tank and filter.....    | 4-28      | 4-27 |
| Adjustment:                         |           |      | Radiator.....                         | 4-53      | 4-50 |
| Carburetor .....                    | 4-42      | 4-42 | Cleaning and inspection:              |           |      |
| Direction shift lever linkage ..... | 4-83      | 4-77 | Accelerator pedal and linkage .....   | 4-60      | 4-48 |
| Drag link.....                      | 4-60      | 4-57 | Battery.....                          | 4-37      | 4-39 |
| Fan and alternator belts.....       | 4-55      | 4-53 | Battery cables.....                   | 4-37      | 4-39 |
| Governor.....                       | 4-49      | 4-47 | Brake master cylinder                 |           |      |
| Hydraulic lift chain .....          | 4-26      | 4-23 | and brake lines.....                  | 4-76      | 4-72 |
| Parking brake lever and linkage..   | 4-73      | 4-66 | Drag link.....                        | 4-60      | 4-57 |
| Service brake pedal linkage .....   | 4-78      | 4-73 | Engine oil filter and hoses.....      | 4-67      | 4-61 |
| Tie rods.....                       | 4-61      | 4-59 | Exhaust muffler and piping.....       | 4-58      | 4-56 |
| Valve.....                          | 4-66      | 4-61 | Fuel tank, fuel lines,                |           |      |
| Air cleaner:                        |           |      | and fittings .....                    | 4-48      | 4-46 |
| Cleaning and inspection .....       | 4-45      | 4-45 | Hydraulic lift chain .....            | 4-26      | 4-23 |
| Reassembly and installation .....   | 4-45      | 4-45 | Hydraulic lines and fittings .....    | 4-27      | 4-25 |
| Removal and disassembly.....        | 4-45      | 4-45 | Ignition distributor .....            | 4-34      | 4-35 |
| Alternator:                         |           |      | Instrument panel.....                 | 4-22      | 4-20 |
| Installation.....                   | 4-31      | 4-29 | Intake and exhaust manifold .....     | 4-68      | 4-63 |
| Removal.....                        | 4-31      | 4-29 | Lights .....                          | 4-38      | 4-39 |
| Testing.....                        | 4-31      | 4-29 | Parking brake handle and linkage .... | 4-73      | 4-66 |
| Antifreeze:                         |           |      | Positive crankcase                    |           |      |
| Freezing points, composition and    |           |      | ventilation valve.....                | 4-47      | 4-46 |
| specific gravities of military      |           |      | Spark plugs.....                      | 4-35      | 4-37 |
| antifreeze materials.....           | 3-4       | 3-1  | Starting motor.....                   | 4-33      | 4-37 |
| <b>B</b>                            |           |      |                                       |           |      |
| Battery:                            |           |      | Tie rods .....                        | 4-61      | 4-59 |
| Cleaning.....                       | 4-37      | 4-39 | Tilt-lock valve.....                  | 4-24      | 4-21 |
| Cleaning and inspection .....       | 4-37      | 4-39 | Transmission oil filter               |           |      |
| Installation.....                   | 4-37      | 4-39 | and lines .....                       | 4-82      | 4-76 |
| Removal.....                        | 4-37      | 4-39 | Wheel bearings.....                   | 4-71      | 4-64 |
| Service.....                        | 3-4       | 3-1  | Wheels and tires.....                 | 4-70      | 4-64 |
| Testing.....                        | 4-37      | 4-39 | Compression test.....                 | 4-63      | 4-60 |
| Battery cables:                     |           |      | Controls and instruments .....        | 2-1       | 2-1  |
| Cleaning and inspection .....       | 4-37      | 4-39 | Coolant .....                         | 3-4       | 3-1  |
| Installation.....                   | 4-37      | 4-39 | Cooling system:                       |           |      |
| Removal.....                        | 4-37      | 4-39 | Fan and alternator belts .....        | 4-55      | 4-53 |
| Bearings, wheel .....               | 4-71      | 4-64 | General .....                         | 4-52      | 4-50 |
| Belts, fan and alternator.....      | 4-55      | 4-53 | Radiator.....                         | 4-53      | 4-50 |
| Bleeding the brake system .....     | 4-75      | 4-67 | Thermostat .....                      | 4-54      | 4-53 |
| Body panels and hoods.....          | 4-21      | 4-18 | Water pump and fan blade.....         | 4-56      | 4-54 |
| Brake master cylinder:              |           |      | <b>D</b>                              |           |      |
| Cleaning and inspection .....       | 4-76      | 4-72 | Depositing load .....                 | 2-7       | 2-4  |
| Installation.....                   | 4-76      | 4-72 | Description:                          |           |      |
| Removal.....                        | 4-76      | 4-72 | Drive system.....                     | 4-81      | 4-76 |
| Brakes:                             |           |      | Engine .....                          | 4-62      | 4-60 |
| General .....                       | 4-72      | 4-65 | Hydraulic system .....                | 4-23      | 4-21 |
| Master cylinder.....                | 4-76      | 4-72 | Parking brake system .....            | 4-72      | 4-65 |
| Parking brake handle and linkage    | 4-73      | 4-66 | Service brake system.....             | 4-72      | 4-65 |
| Service brake pedal                 |           |      | Steering system.....                  | 4-59      | 4-57 |
| linkage adjustment.....             | 4-78      | 4-74 | Destruction of materiel               |           |      |
| <b>C</b>                            |           |      |                                       |           |      |
| Carburetor:                         |           |      | to prevent enemy use.....             | 1-5       | 1-1  |
| Adjustment.....                     | 4-42      | 4-42 | Differences in models.....            | 1-9       | 1-6  |
| Installation.....                   | 4-42      | 4-42 | Dimensions and weight .....           | 1-8       | 1-3  |
| Removal.....                        | 4-42      | 4-42 |                                       |           |      |

|  | Paragraph | Page |   | Paragraph | Page |
|--|-----------|------|---|-----------|------|
| Direction shift lever linkage adjustment ..... | 4-83      | 4-77 | Engine starter:                           |           |      |
| Disassembly: .....                             |           |      | Tabulated data.....                       | 1-8       | 1-3  |
| Accelerator pedal and linkage.....             | 4-50      | 4-48 | Exhaust muffler and piping:               |           |      |
| Air cleaner.....                               | 4-45      | 4-45 | Cleaning and inspection.....              | 4-58      | 4-56 |
| Crankcase breather .....                       | 4-46      | 4-46 | Reassembly and installation .....         | 4-58      | 4-56 |
| Drag link.....                                 | 4-60      | 4-57 | Removal and disassembly .....             | 4-58      | 4-56 |
| Engine oil filter and hoses.....               | 4-67      | 4-61 | Exhaust system:                           |           |      |
| Exhaust muffler and piping .....               | 4-58      | 4-56 | Exhaust muffler and piping.....           | 4-58      | 4-56 |
| Fuel tank, fuel lines and fittings.....        | 4-48      | 4-46 | <b>F</b>                                  |           |      |
| Hydraulic oil tank and filter .....            | 4-28      | 4-27 | Fan and alternator belts:                 |           |      |
| Instrument panel .....                         | 4-22      | 4-20 | Adjustment .....                          | 4-55      | 4-53 |
| Lights .....                                   | 4-38      | 4-39 | Replacement .....                         | 4-55      | 4-53 |
| Positive crankcase ventilation valve .....     | 4-47      | 4-46 | Fan blade:                                |           |      |
| Transmission oil filter and lines .....        | 4-82      | 4-76 | Cleaning and inspection.....              | 4-56      | 4-54 |
| Wheel bearings .....                           | 4-71      | 4-64 | Reassembly and installation .....         | 4-56      | 4-54 |
| Dismantling for movement.....                  | 4-2       | 4-1  | Removal and disassembly .....             | 4-56      | 4-54 |
| Distributor:                                   |           |      | Filter, hydraulic oil:                    |           |      |
| Point repair and replacement.....              | 4-34      | 4-35 | Cleaning .....                            | 4-28      | 4-27 |
| Tabulated data .....                           | 1-8       | 1-3  | Disassembly.....                          | 4-28      | 4-27 |
| Drag link:                                     |           |      | Reassembly.....                           | 4-28      | 4-27 |
| Cleaning and inspection .....                  | 4-60      | 4-57 | Filter service:                           |           |      |
| Reassembly, installation, and adjustment ..... | 4-60      | 4-57 | Transmission oil filter.....              | 4-82      | 4-76 |
| Removal and disassembly.....                   | 4-60      | 4-57 | Floor plate .....                         | 4-18      | 4-16 |
| Draining hydraulic oil tank.....               | 4-28      | 4-27 | Fork lift truck:                          |           |      |
| Drive system:                                  |           |      | Tabulated data.....                       | 1-8       | 1-3  |
| Description .....                              | 4-81      | 4-76 | Fuel filter:                              |           |      |
| Driving truck .....                            | 2-4       | 2-3  | Installation.....                         | 4-44      | 4-44 |
| Driving with load .....                        | 2-6       | 2-4  | Removal .....                             | 4-44      | 4-44 |
| <b>E</b>                                       |           |      | Servicing .....                           | 4-44      | 4-44 |
| Electrical system:                             |           |      | Fuel pump:                                |           |      |
| Alternator .....                               | 4-31      | 4-29 | Installation.....                         | 4-43      | 4-44 |
| Battery and cables.....                        | 4-37      | 4-39 | Removal.....                              | 4-43      | 4-44 |
| General.....                                   | 4-30      | 4-29 | Testing .....                             | 4-43      | 4-44 |
| Ignition coil.....                             | 4-36      | 4-38 | Fuel system:                              |           |      |
| Ignition distributor.....                      | 4-34      | 4-35 | Accelerator pedal and linkage .....       | 4-50      | 4-48 |
| Instrument panel .....                         | 4-22      | 4-20 | Air cleaner .....                         | 4-45      | 4-45 |
| Lights .....                                   | 4-38      | 4-39 | Carburetor .....                          | 4-42      | 4-42 |
| Spark plugs .....                              | 4-35      | 4-37 | Fuel filter .....                         | 4-44      | 4-44 |
| Starting motor .....                           | 4-33      | 4-34 | Fuel pump .....                           | 4-43      | 4-44 |
| Voltage regulator .....                        | 4-32      | 4-30 | Fuel tank, fuel lines and fittings .....  | 4-48      | 4-46 |
| Engine:  |           |      | General .....                             | 4-41      | 4-41 |
| Coolant .....                                  | 3-4       | 3-1  | Governor adjustment .....                 | 4-49      | 4-47 |
| Description .....                              | 4-62      | 4-60 | Positive crankcase ventilation valve..... | 4-47      | 4-46 |
| General.....                                   | 4-62      | 4-60 | Fuel tank, fuel lines, and fittings:      |           |      |
| Intake and exhaust manifold.....               | 4-68      | 4-63 | Inspection.....                           | 4-48      | 4-46 |
| Oil filter .....                               | 4-67      | 4-61 | <b>G</b>                                  |           |      |
| Oil service .....                              | 3-4       | 3-1  | Governor:                                 |           |      |
| Testing.....                                   | 4-63      | 4-60 | Adjustment .....                          | 4-49      | 4-47 |
| Engine alternator:                             |           |      | <b>H</b>                                  |           |      |
| Tabulated data .....                           | 1-8       | 1-3  | Headlights.....                           | 4-38      | 4-39 |
| Engine oil filter and hoses:                   |           |      | Horn and wiring .....                     | 4-40      | 4-41 |
| Cleaning and inspection .....                  | 4-67      | 4-61 | Hydraulic lift chain:                     |           |      |
| Disassembly.....                               | 4-67      | 4-61 | Adjustment .....                          | 4-26      | 4-23 |
| Reassembly .....                               | 4-67      | 4-61 | Cleaning and inspection.....              | 4-26      | 4-23 |
| Service.....                                   | 4-67      | 4-61 | Installation.....                         | 4-26      | 4-23 |
|  |           |      | Removal.....                              | 4-26      | 4-23 |

|  | Paragraph | Page |   | Paragraph | Page |
|--|-----------|------|---|-----------|------|
| Hydraulic lines and fittings:            |           |      | Installation-continued                  |           |      |
| Cleaning and inspection .....            | 4-27      | 4-25 | Instrument panel .....                  | 4-22      | 4-20 |
| Installation .....                       | 4-27      | 4-25 | Intake and exhaust manifold .....       | 4-68      | 4-63 |
| Removal .....                            | 4-27      | 4-25 | Lights .....                            | 4-38      | 4-39 |
| Hydraulic oil tank and filter:           |           |      | Parking brake handle and linkage .....  | 4-73      | 4-66 |
| Cleaning .....                           | 4-28      | 4-27 | Positive crankcase                      |           |      |
| Disassembly .....                        | 4-28      | 4-27 | ventilation valve .....                 | 4-47      | 4-46 |
| Draining tank .....                      | 4-28      | 4-27 | Radiator .....                          | 4-53      | 4-50 |
| Reassembly .....                         | 4-28      | 4-27 | Spark plugs .....                       | 4-35      | 4-37 |
| Refilling tank .....                     | 4-28      | 4-27 | Starting motor .....                    | 4-33      | 4-34 |
| Hydraulic reservoir breather:            |           |      | Thermostat .....                        | 4-54      | 4-53 |
| Cleaning .....                           | 4-29      | 4-29 | Tilt cylinder .....                     | 4-25      | 4-22 |
| Installation .....                       | 4-29      | 4-29 | Tilt-lock valve .....                   | 4-24      | 4-21 |
| Removal .....                            | 4-29      | 4-29 | Transmission oil filter and lines ..... | 4-82      | 4-76 |
| Hydraulic system:                        |           |      | Voltage regulator .....                 | 4-32      | 4-30 |
| Description .....                        | 4-23      | 4-21 | Wheels and tires .....                  | 4-70      | 4-64 |
| General .....                            | 4-23      | 4-21 | Instrument panel:                       |           |      |
| Hydraulic lift chain .....               | 4-26      | 4-23 | Cleaning and inspection .....           | 4-22      | 4-20 |
| Hydraulic lines and fittings .....       | 4-27      | 4-25 | Reassembly and installation .....       | 4-22      | 4-20 |
| Hydraulic oil tank and filter .....      | 4-28      | 4-27 | Removal and disassembly .....           | 4-22      | 4-20 |
| Hydraulic reservoir breather .....       | 4-29      | 4-29 | Intake and exhaust manifold:            |           |      |
| Tilt cylinder .....                      | 4-25      | 4-22 | Cleaning and inspection .....           | 4-68      | 4-63 |
| Tilt-lock valve .....                    | 4-24      | 4-21 | Installation .....                      | 4-68      | 4-63 |
|  |           |      | Removal .....                           | 4-68      | 4-63 |
| <b>I</b>                                 |           |      | Interference suppression components:    |           |      |
| Identification .....                     | 1-8       | 1-3  | Primary .....                           | 4-13      | 4-13 |
| Ignition coil:                           |           |      | Replacement .....                       | 4-14      | 4-15 |
| Installation .....                       | 4-36      | 4-38 | Secondary .....                         | 4-13      | 4-13 |
| Removal .....                            | 4-36      | 4-38 | Testing .....                           | 4-15      | 4-15 |
| Testing .....                            | 4-36      | 4-38 | Introduction:                           |           |      |
| Ignition distributor:                    |           |      | Forms and records .....                 | 1-2       | 1-1  |
| Cleaning and inspection .....            | 4-34      | 4-35 | Scope .....                             | 1-1       | 1-1  |
| Distributor point repair                 |           |      |   |           |      |
| and replacement .....                    | 4-34      | 4-35 | <b>L</b>                                |           |      |
| Installation .....                       | 4-34      | 4-35 | Lamp replacement .....                  | 4-38      | 4-39 |
| Removal .....                            | 4-34      | 4-35 | Lights:                                 |           |      |
| Ignition timing test .....               | 4-64      | 4-60 | Cleaning and inspection .....           | 4-38      | 4-39 |
| Inspecting and servicing equipment       | 4-1       | 4-1  | Lamp replacement .....                  | 4-38      | 4-39 |
| Inspection and testing:                  |           |      | Reassembly and installation .....       | 4-38      | 4-39 |
| Radiator .....                           | 4-53      | 4-50 | Removal and disassembly .....           | 4-38      | 4-39 |
| Thermostat .....                         | 4-54      | 4-53 | Lubrication:                            |           |      |
| Installation:                            |           |      | Detailed lubrication information .....  | 3-2       | 3-1  |
| Accelerator pedal and linkage .....      | 4-50      | 4-48 | General lubrication information .....   | 3-1       | 3-1  |
| Air cleaner .....                        | 4-45      | 4-45 |   |           |      |
| Alternator .....                         | 4-31      | 4-29 | <b>M</b>                                |           |      |
| Battery .....                            | 4-37      | 4-39 | Master cylinder, brake .....            | 4-76      | 4-72 |
| Battery cables .....                     | 4-37      | 4-39 | Movement to a new worksite:             |           |      |
| Brake master cylinder                    |           |      | Dismantling for movement .....          | 4-2       | 4-1  |
| and brake lines .....                    | 4-76      | 4-72 | Reinstallation after movement .....     | 4-3       | 4-1  |
| Carburetor .....                         | 4-42      | 4-42 |   |           |      |
| Drag link .....                          | 4-60      | 4-57 | <b>O</b>                                |           |      |
| Exhaust muffler and piping .....         | 4-58      | 4-56 | Oil service:                            |           |      |
| Fuel filter .....                        | 4-44      | 4-44 | Engine .....                            | 4-8       | 4-2  |
| Fuel pump .....                          | 4-43      | 4-44 | Transmission .....                      | 4-8       | 4-1  |
| Fuel tank, fuel lines and fittings ..... | 4-48      | 4-46 | Operation:                              |           |      |
| Hydraulic lift chain .....               | 4-26      | 4-23 | In extreme cold .....                   | 2-8       | 2-4  |
| Hydraulic lines and fittings .....       | 4-27      | 4-25 | In extreme heat .....                   | 2-9       | 2-4  |
| Ignition coil .....                      | 4-36      | 4-38 | In high altitudes .....                 | 2-12      | 2-5  |
| Ignition distributor .....               | 4-34      | 4-35 | In salt water areas .....               | 2-11      | 2-5  |

|                                       | Paragraph | Page |   | Paragraph | Page |
|---------------------------------------|-----------|------|---|-----------|------|
| In sandy or dusty areas .....         | 2-10      | 2-4  | Fuel tanks, fuel lines,                 |           |      |
| Under unusual conditions .....        | 2-8       | 2-4  | and fittings .....                      | 4-48      | 4-46 |
| Under usual conditions .....          | 2-1       | 2-1  | Hydraulic oil tank and filter.....      | 4-28      | 4-27 |
| Operation under unusual conditions:   |           |      | Instrument panel.....                   | 4-22      | 4-20 |
| In extreme cold.....                  | 2-8       | 2-4  | Lights .....                            | 4-38      | 4-39 |
| In extreme heat .....                 | 2-9       | 2-4  | Positive crankcase ventilation valve .. | 4-47      | 4-46 |
| In high altitudes.....                | 2-12      | 2-5  | Transmission oil filter and lines.....  | 4-82      | 4-76 |
| In salt water areas.....              | 2-11      | 2-5  | Wheel bearings.....                     | 4-71      | 4-64 |
| In sandy or dusty areas .....         | 2-10      | 2-4  | Records and forms.....                  | 1-2       | 1-1  |
| Operation under usual conditions:     |           |      | Refilling hydraulic oil tank.....       | 4-28      | 4-27 |
| Depositing load .....                 | 2-7       | 2-4  | Reinstallation after movement .....     | 4-3       | 4-1  |
| Driving truck.....                    | 2-4       | 2-3  | Removal:                                |           |      |
| Driving with load.....                | 2-6       | 2-4  | Accelerator pedal and linkage .....     | 4-50      | 4-48 |
| General.....                          | 2-1       | 2-1  | Air cleaner .....                       | 4-45      | 4-45 |
| Picking up load.....                  | 2-5       | 2-3  | Alternator.....                         | 4-31      | 4-29 |
| Starting .....                        | 2-2       | 2-1  | Battery.....                            | 4-37      | 4-39 |
| Stopping.....                         | 2-3       | 2-2  | Battery cables.....                     | 4-37      | 4-39 |
| Operator's maintenance: .....         |           |      | Brake master cylinder and               |           |      |
| Air cleaner service.....              | 3-4       | 3-1  | brake lines.....                        | 4-76      | 4-72 |
| Battery service.....                  | 3-4       | 3-1  | Carburetor .....                        | 4-42      | 4-42 |
| Engine coolant .....                  | 3-4       | 3-1  | Drag link.....                          | 4-60      | 4-57 |
| Operator's seat .....                 | 4-20      | 4-16 | Exhaust muffler and piping.....         | 4-58      | 4-56 |
| Organizational maintenance.....       |           |      | Fuel filter.....                        | 4-44      | 4-44 |
| repair parts.....                     | 4-6       | 4-1  | Fuel pump .....                         | 4-43      | 4-44 |
| Overhead guard.....                   | 4-16      | 4-15 | Hydraulic lift chain .....              | 4-26      | 4-23 |
|                                       |           |      | Hydraulic lines and fittings .....      | 4-27      | 4-25 |
| <b>P</b>                              |           |      | Ignition coil .....                     | 4-36      | 4-38 |
| Packing, wheel bearing .....          | 4-71      | 4-64 | Ignition distributor .....              | 4-34      | 4-35 |
| Parking brake handle and linkage:     |           |      | Instrument panel.....                   | 4-22      | 4-20 |
| Adjustment.....                       | 4-73      | 4-66 | Intake and exhaust manifold .....       | 4-68      | 4-63 |
| Cleaning and inspection .....         | 4-73      | 4-66 | Lights .....                            | 4-38      | 4-39 |
| Installation.....                     | 4-74      | 4-66 | Parking brake handle and linkage ....   | 4-73      | 4-66 |
| Removal.....                          | 4-74      | 4-66 | Positive crankcase                      |           |      |
| Parking brake system:                 |           |      | ventilation valve.....                  | 4-47      | 4-46 |
| Description .....                     | 4-72      | 4-65 | Radiator.....                           | 4-53      | 4-50 |
| Performance .....                     | 1-8       | 1-3  | Spark plugs .....                       | 4-35      | 4-37 |
| Picking up load .....                 | 2-5       | 2-3  | Starting motor.....                     | 4-33      | 4-34 |
| Positive crankcase ventilation valve: |           |      | Thermostat .....                        | 4-54      | 4-53 |
| Cleaning and inspection .....         | 4-47      | 4-46 | Tilt cylinder .....                     | 4-25      | 4-22 |
| Reassembly and installation .....     | 4-47      | 4-46 | Tilt-lock valve.....                    | 4-24      | 4-21 |
| Removal and disassembly.....          | 4-47      | 4-46 | Transmission oil filter                 |           |      |
| Service.....                          | 4-47      | 4-46 | and lines .....                         | 4-82      | 4-76 |
| Preventive maintenance checks         |           |      | Voltage regulator .....                 | 4-32      | 4-30 |
| and services .....                    | 3-4       | 3-1  | Wheel bearings.....                     | 4-71      | 4-64 |
|                                       |           |      | Wheels and tires.....                   | 4-70      | 4-64 |
| <b>R</b>                              |           |      | Replacement:                            |           |      |
| Radiator:                             |           |      | Fan and alternator belts .....          | 4-55      | 4-53 |
| Cleaning.....                         | 4-53      | 4-50 |   |           |      |
| Inspection and testing.....           | 4-53      | 4-50 | <b>S</b>                                |           |      |
| Installation.....                     | 4-53      | 4-50 | Scope .....                             | 1-1       | 1-1  |
| Removal.....                          | 4-53      | 4-50 | Service:                                |           |      |
| Radio Interference suppression .....  | 4-12      | 4-13 | Air cleaner .....                       | 4-45      | 4-45 |
| Reassembly:                           |           |      | Battery.....                            | 3-4       | 3-1  |
| Accelerator pedal and linkage.....    | 4-50      | 4-48 | Differential .....                      | 4-80      | 4-76 |
| Air cleaner.....                      | 4-45      | 4-45 | Engine filter and hoses.....            | 4-67      | 4-62 |
| Drag link.....                        | 4-60      | 4-57 | Positive crankcase                      |           |      |
| Engine oil filter and hoses.....      | 4-67      | 4-61 | ventilation valve.....                  | 4-47      | 4-46 |
| Exhaust muffler and piping .....      | 4-58      | 4-56 |   |           |      |

|                                | Paragraph | Page |                               | Paragraph | Page |
|--------------------------------|-----------|------|-------------------------------|-----------|------|
| Service brakes:                |           |      | Thermostat:                   |           |      |
| Bleeding the brake system..... | 4-75      | 4-67 | Inspection and testing .....  | 4-54      | 4-53 |
| Servicing:                     |           |      | Installation .....            | 4-54      | 4-53 |
| Fuel filter .....              | 4-44      | 4-44 | Removal .....                 | 4-54      | 4-53 |
| Spark plugs:                   |           |      | Tie rods:                     |           |      |
| Cleaning and inspection .....  | 4-35      | 4-37 | Adjustment .....              | 4-61      | 4-59 |
| Installation.....              | 4-35      | 4-37 | Tilt cylinder:                |           |      |
| Removal.....                   | 4-35      | 4-37 | Installation.....             | 4-25      | 4-22 |
| Starting.....                  | 2-2       | 2-1  | Removal.....                  | 4-25      | 4-22 |
| Starting motor:                |           |      | Tilt-lock valve:              |           |      |
| Cleaning and inspection .....  | 4-33      | 4-34 | Cleaning and inspection.....  | 4-24      | 4-21 |
| Installation.....              | 4-33      | 4-34 | Installation.....             | 4-24      | 4-21 |
| Removal.....                   | 4-33      | 4-34 | Removal.....                  | 4-24      | 4-21 |
| Testing.....                   | 4-33      | 4-34 | Tires:                        |           |      |
| Steering:                      |           |      | Tabulated data.....           | 1-8       | 1-3  |
| General.....                   | 4-59      | 4-57 | Torque converter:             |           |      |
| Drag link.....                 | 4-60      | 4-57 | Tabulated data.....           | 1-8       | 1-3  |
| Steering system:               |           |      | Transmission:                 |           |      |
| Description .....              | 4-59      | 4-57 | Direction shift level         |           |      |
| Stopping.....                  | 2-3       | 2-2  | linkage adjustment .....      | 4-83      | 4-77 |
|                                |           |      | General .....                 | 4-81      | 4-76 |
|                                |           |      | Oil filter and lines.....     | 4-82      | 4-76 |
|                                |           |      | Oil service .....             | 4-8       | 4-2  |
|                                |           |      | Tabulated data.....           | 1-8       | 1-3  |
|                                |           |      | Troubleshooting:              |           |      |
|                                |           |      | Operator/Crew .....           | 3-5       | 3-3  |
|                                |           |      | Organizational .....          | 4-11      | 4-5  |
|                                |           |      | Voltage regulator:            |           |      |
|                                |           |      | Installation.....             | 4-32      | 4-30 |
|                                |           |      | Removal.....                  | 4-32      | 4-30 |
|                                |           |      | Tabulated data.....           | 1-8       | 1-3  |
|                                |           |      | Testing and adjustment.....   | 4-32      | 4-30 |
|                                |           |      | Wheel bearings:               |           |      |
|                                |           |      | Cleaning and inspection.....  | 4-71      | 4-64 |
|                                |           |      | Packing .....                 | 4-71      | 4-64 |
|                                |           |      | Reassembly.....               | 4-71      | 4-64 |
|                                |           |      | Removal and disassembly ..... | 4-71      | 4-64 |
|                                |           |      | Wheels and tires:             |           |      |
|                                |           |      | Cleaning and inspection.....  | 4-70      | 4-64 |
|                                |           |      | General .....                 | 4-69      | 4-64 |
|                                |           |      | Installation.....             | 4-64      | 4-70 |
|                                |           |      | Removal.....                  | 4-64      | 4-70 |
|                                |           |      | Wheel bearings.....           | 4-71      | 4-64 |

**T**

By Order of the Secretary of the Army:

Official:  
VERNE L. BOWERS  
*Major General, United States Army,  
The Adjutant General.*

FRED C. WEYAND  
*General, United States Army,  
Chief of Staff.*

Distribution:

To be distributed in accordance with DA Form 12-25A, (qty rqr block no. 893). Operator's maintenance requirements for Warehouse, Equipment.

U.S. GOVERNMENT PRINTING OFFICE: 1993 O - 342-421 (62748)

RECOMMENDED CHANGES TO EQUIPMENT TECHNICAL PUBLICATIONS



**SOMETHING WRONG WITH THIS PUBLICATION?**

FROM: (PRINT YOUR UNIT'S COMPLETE ADDRESS)

DATE SENT

PUBLICATION NUMBER

PUBLICATION DATE

PUBLICATION TITLE

BE EXACT... PIN-POINT WHERE IT IS

| PAGE NO. | PARA-GRAPH | FIGURE NO. | TABLE NO. |
|----------|------------|------------|-----------|
|----------|------------|------------|-----------|

IN THIS SPACE TELL WHAT IS WRONG AND WHAT SHOULD BE DONE ABOUT IT:

TEAR ALONG PERFORATED LINE

PRINTED NAME, GRADE OR TITLE, AND TELEPHONE NUMBER

SIGN HERE:

DA FORM 2028-2  
1 JUL 79

PREVIOUS EDITIONS  
• ARE OBSOLETE.

P.S.—IF YOUR OUTFIT WANTS TO KNOW ABOUT YOUR RECOMMENDATION MAKE A CARBON COPY OF THIS AND GIVE IT TO YOUR HEADQUARTERS.



